



فالكون باور العالمية

لأجهزة السلامة



متوفر لدينا صناديق الحريق
توريد بأسعار وجودة
لا تقبل المنافسة

خدماتنا غير

Our Services is different

جودتنا غير

Our Quality is different

هاتف: 0547777503

- MATERIAL SUBMITTAL FOR FIRE HOSE CABINET

- PRODUCT (FG-2001R - FGR-2001R)
- TECHNICAL DATA SHEETS (CATALOGUES).
- LPCB APPROVALS.
- PREVIOUS APPROVALS.



-FG-2001R

- DOUBLE DOOR,
- SURFACE MOUNTED,
- MILD STEEL,
- FIRE HOSE REEL CABINET



-FGR-2001R

- DOUBLE DOOR,
- SURFACE MOUNTED,
- MILD STEEL,
- VERTICAL HOSE REEL CABINET

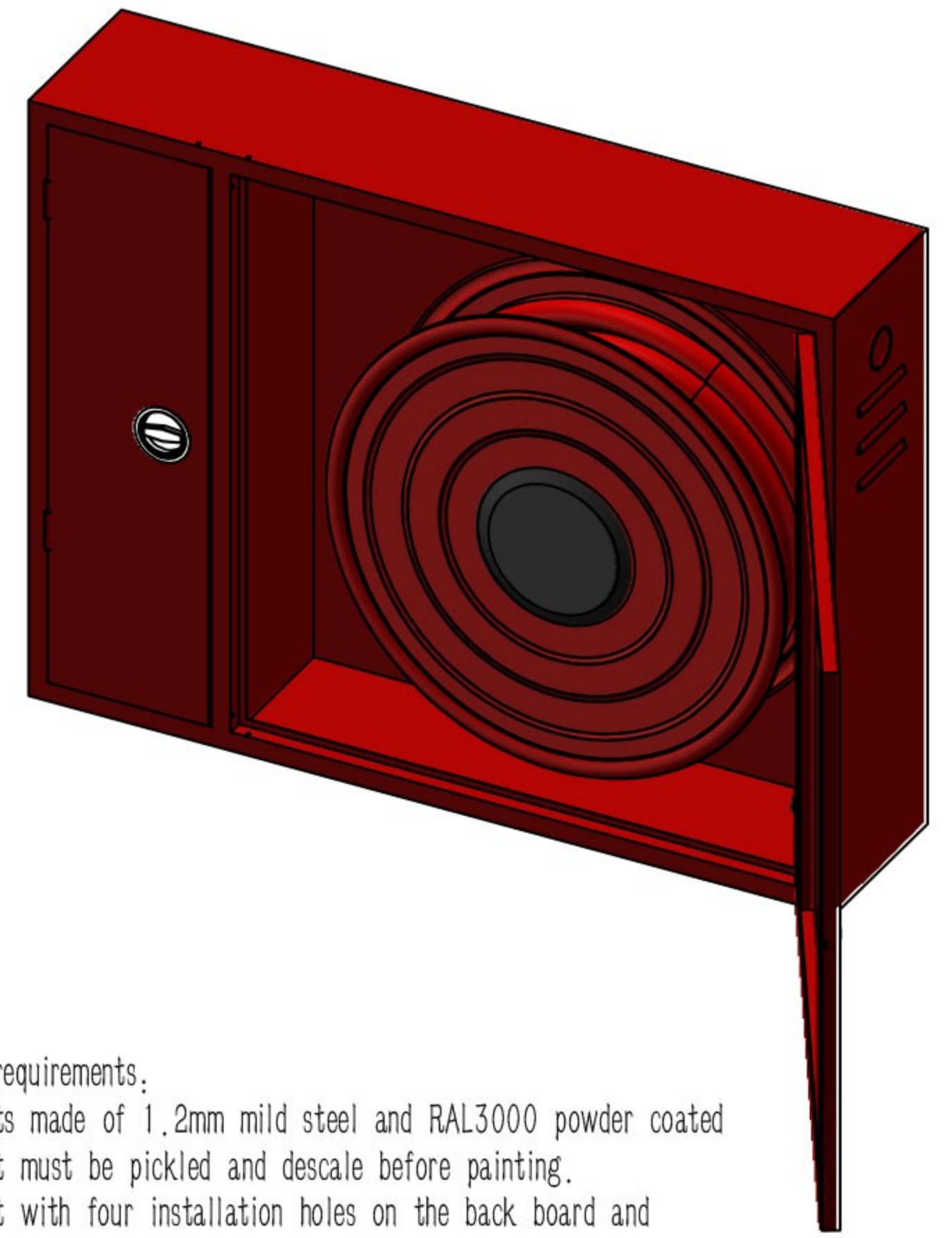
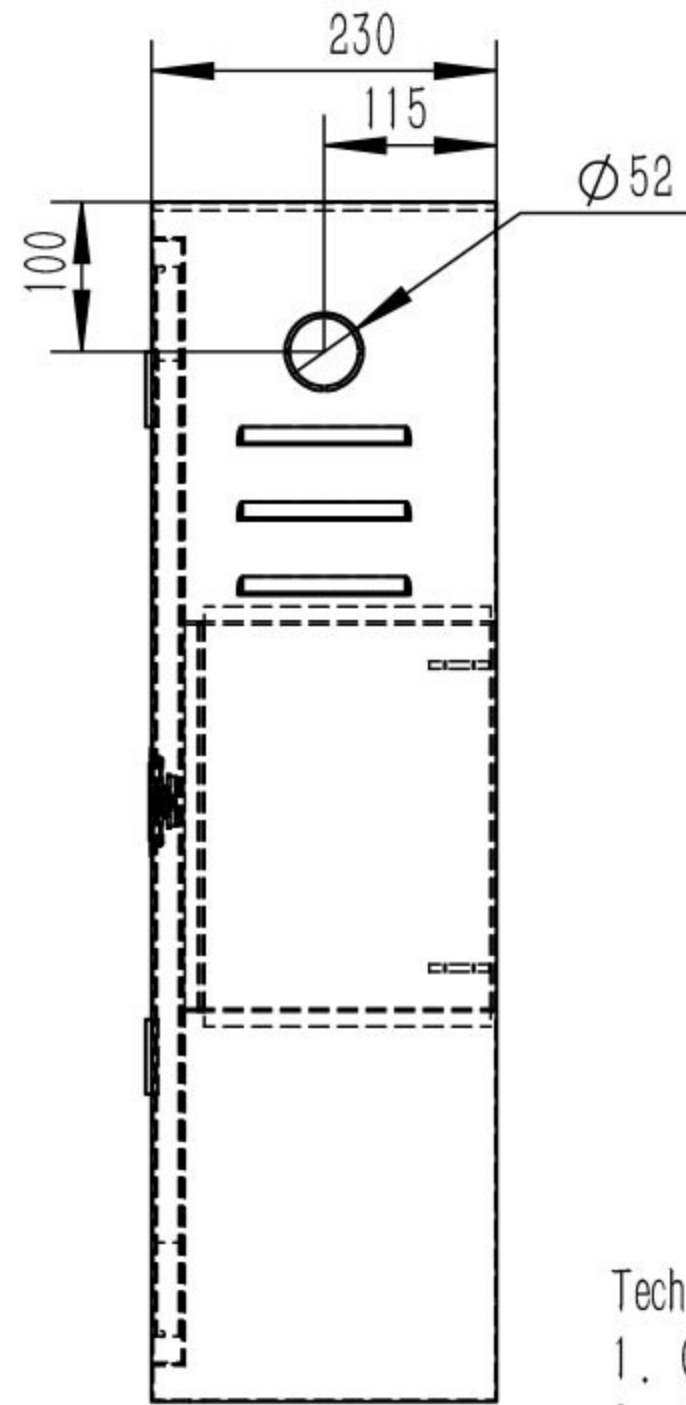
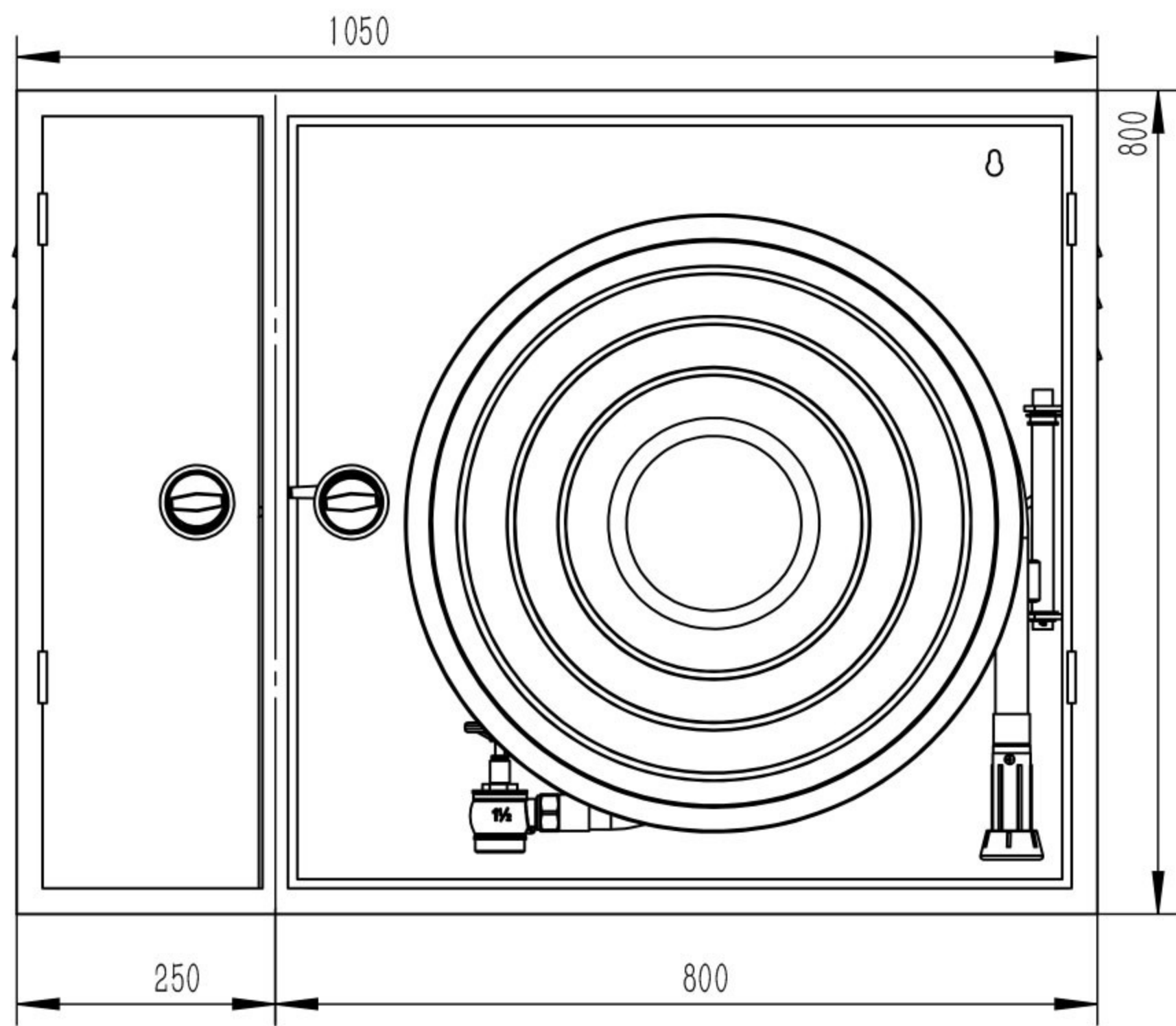

- Technical requirements:
1. Cabinets made of 1.2mm mild steel and RAL3000 powder coated
 2. Cabinet must be pickled and descale before painting.
 3. Cabinet with four installation holes on the back board and two holes at the bottom— ϕ 10 drainage holes at bottom
 4. Cabinet supplied with round S.S round lock and welded hinge

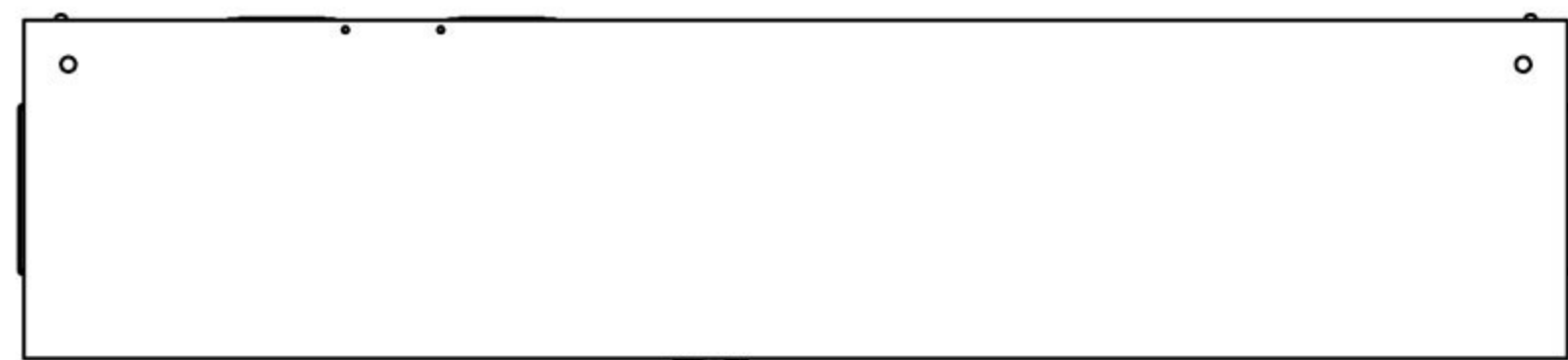

- FG-2001R

△						Name	Surface mounted fire cabinet ,1050x800x230			Approved	
△						Material	SPCC 1.2mm	Surface Treatment	RAL3000	Design	
△						Drawing Number		Unit	mm	Draw	
△								Proportion	1:10		
△										Revision	A
△											
	NO.	Original Size	Modified	Revisor	Auditor	Date					

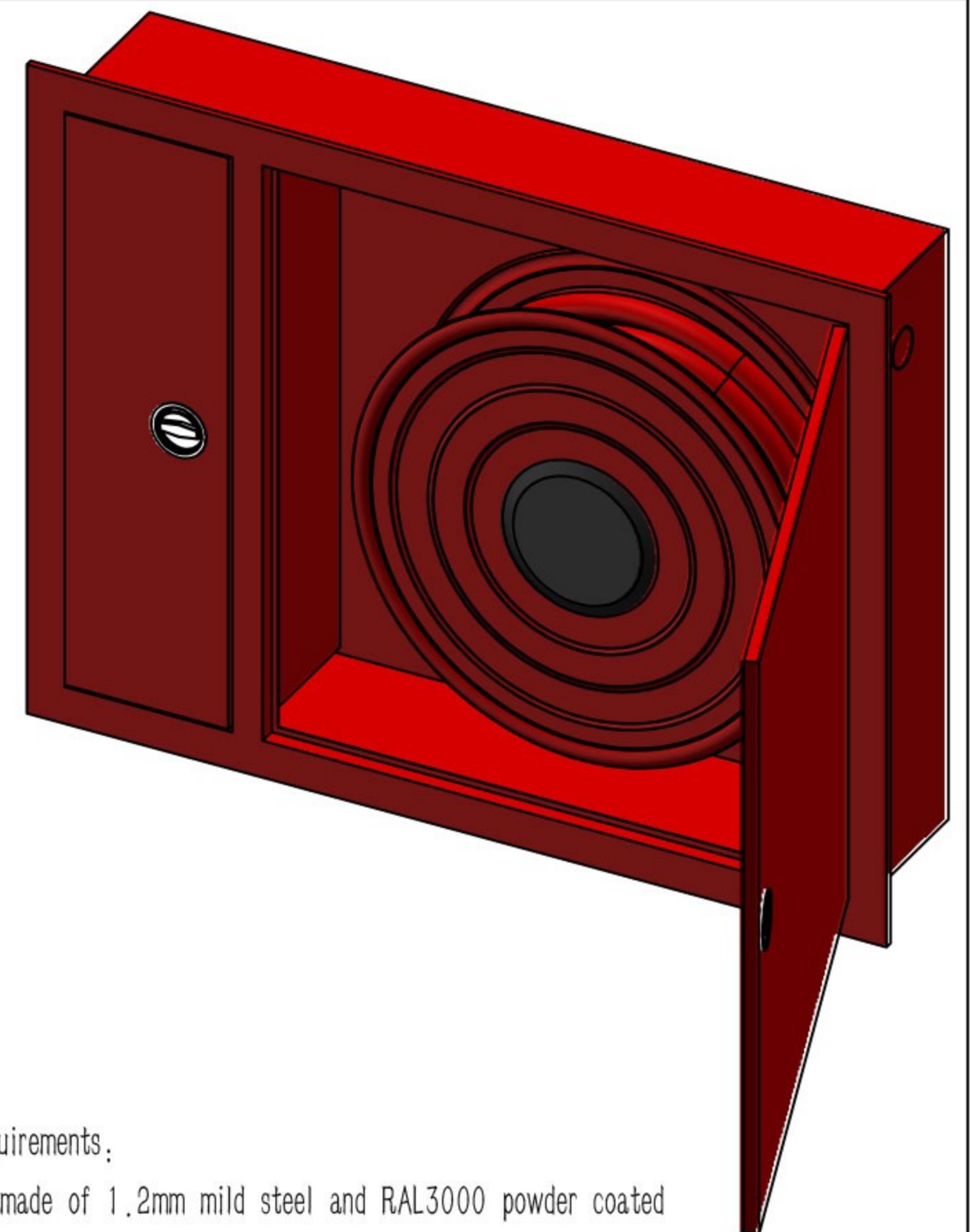
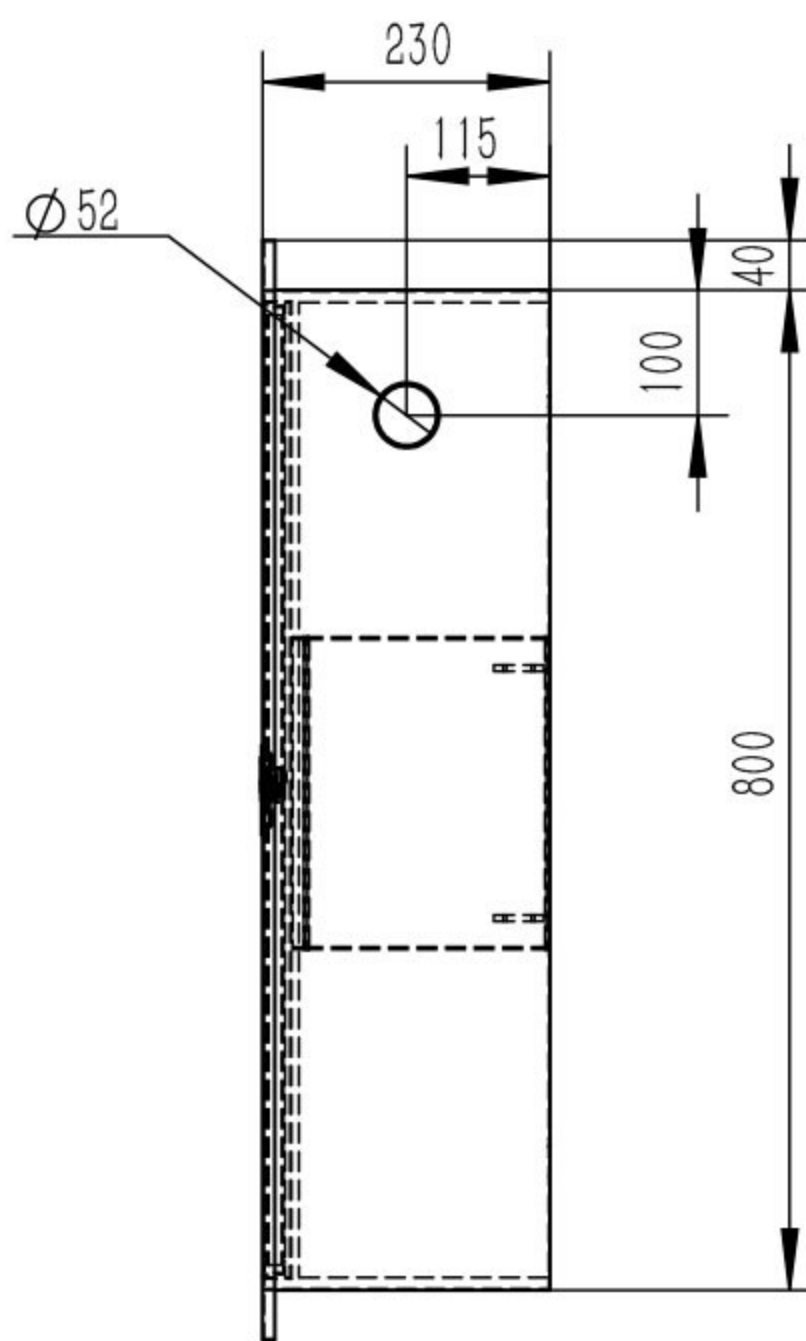
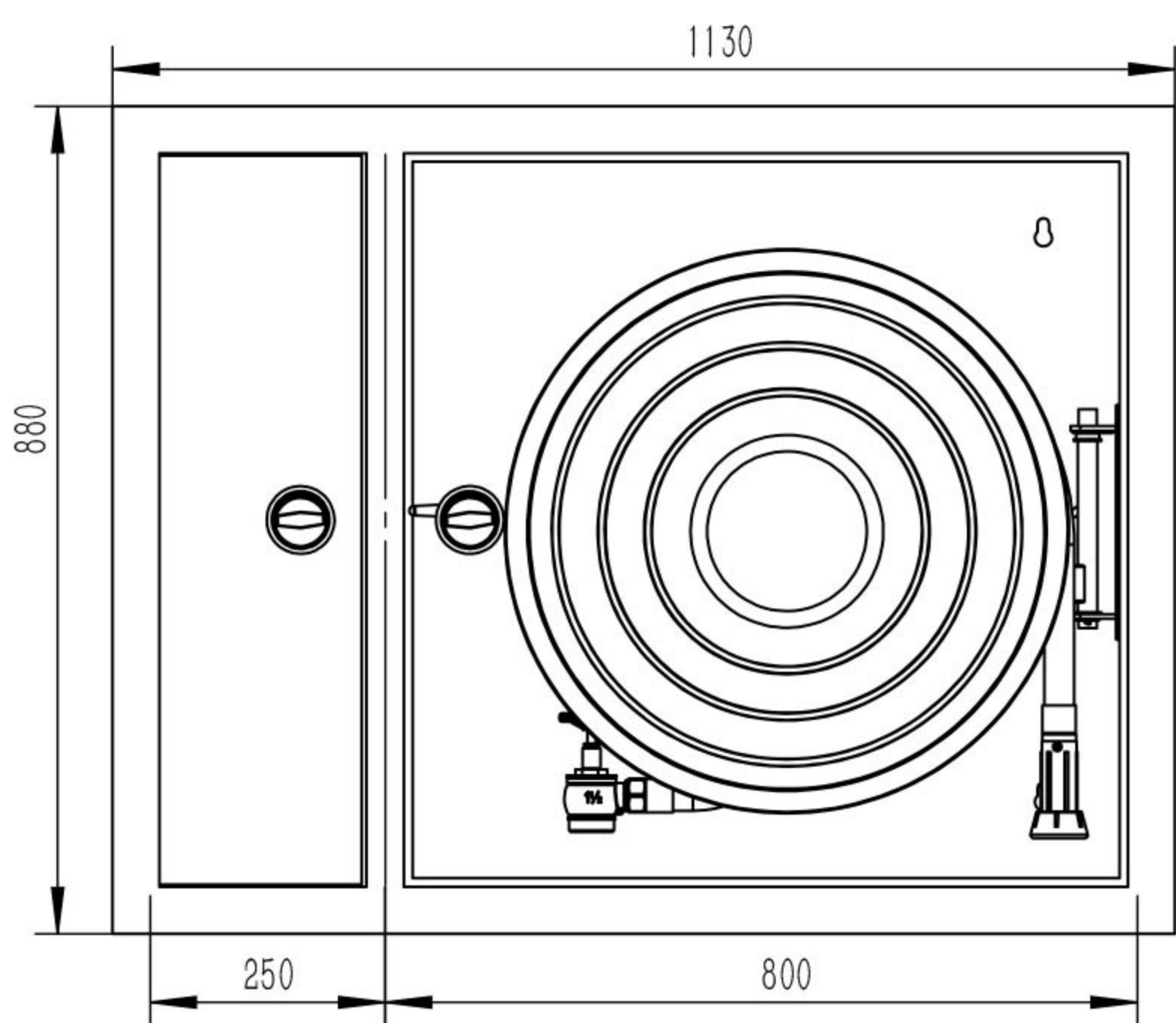

- Technical requirements:
1. Cabinets made of 1.2mm mild steel and RAL3000 powder coated
 2. Cabinet must be pickled and descale before painting.
 3. Cabinet with four installation holes on the back board
 4. Cabinet supplied with round S.S round lock and welded hinge

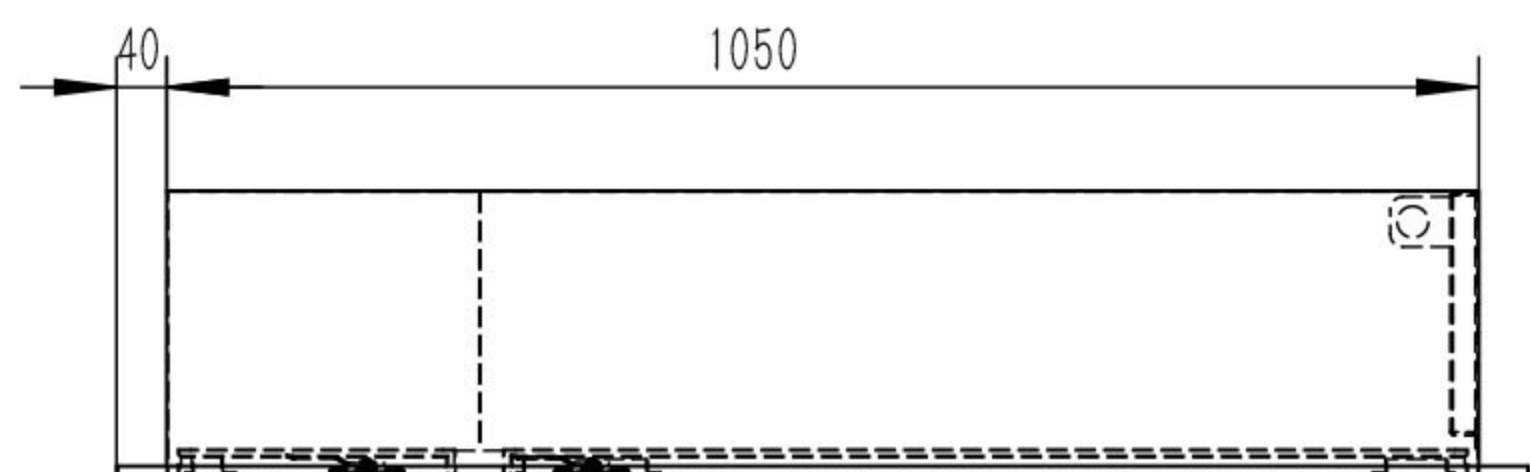

- FGR-2001R

△						Name	Recessed Mounted Fire Cabinet			Approve	
△						Material	SPCC 1.2mm	Surface Colour	RAL3000	Design	
△						Drawing No.		Unit	mm	Draw	
△								Proportion	1:12		
△										Revision	A
△											
	NO.	Original Size	Modified	Revisor	Auditor	Date					

- FIRE CABINET WITH FALCON GOLD HOSE REEL

- CABINET MANUFACTURED FROM MILD STEEL THICKNESS 1.2MM RAL3000 POWDER COATING
- CABINET DIMENSION W 1050MM X H 800MM X D 230 MM
- CABINET FULLY POWDER COATED AND OVEN BAKED FOR APPEARANCE AND PROTECTION FROM RUST.
- SURFACE MOUNTED & RECESSED TYPE, RIGHT HAND OPENED, WITH WELDED HINGE FOR ENOUGH STRENGTH
- CABINET SUPPLIED WITH S.S ROUND LOCK FOR EASY AND FAST OPERATION.
- FULLY APPROVED TO LPCB EN671-1 STANDARD;
- HOSE REEL DRUMS PRESSED ON HYDRAULIC PRESS TO FORM RIBS FOR STRENGTH AND DURABILITY.
- HOSE REEL DISK EDGES ROLLED OVER FOR SAFE HANDLING AND AESTHETIC APPEARANCE.

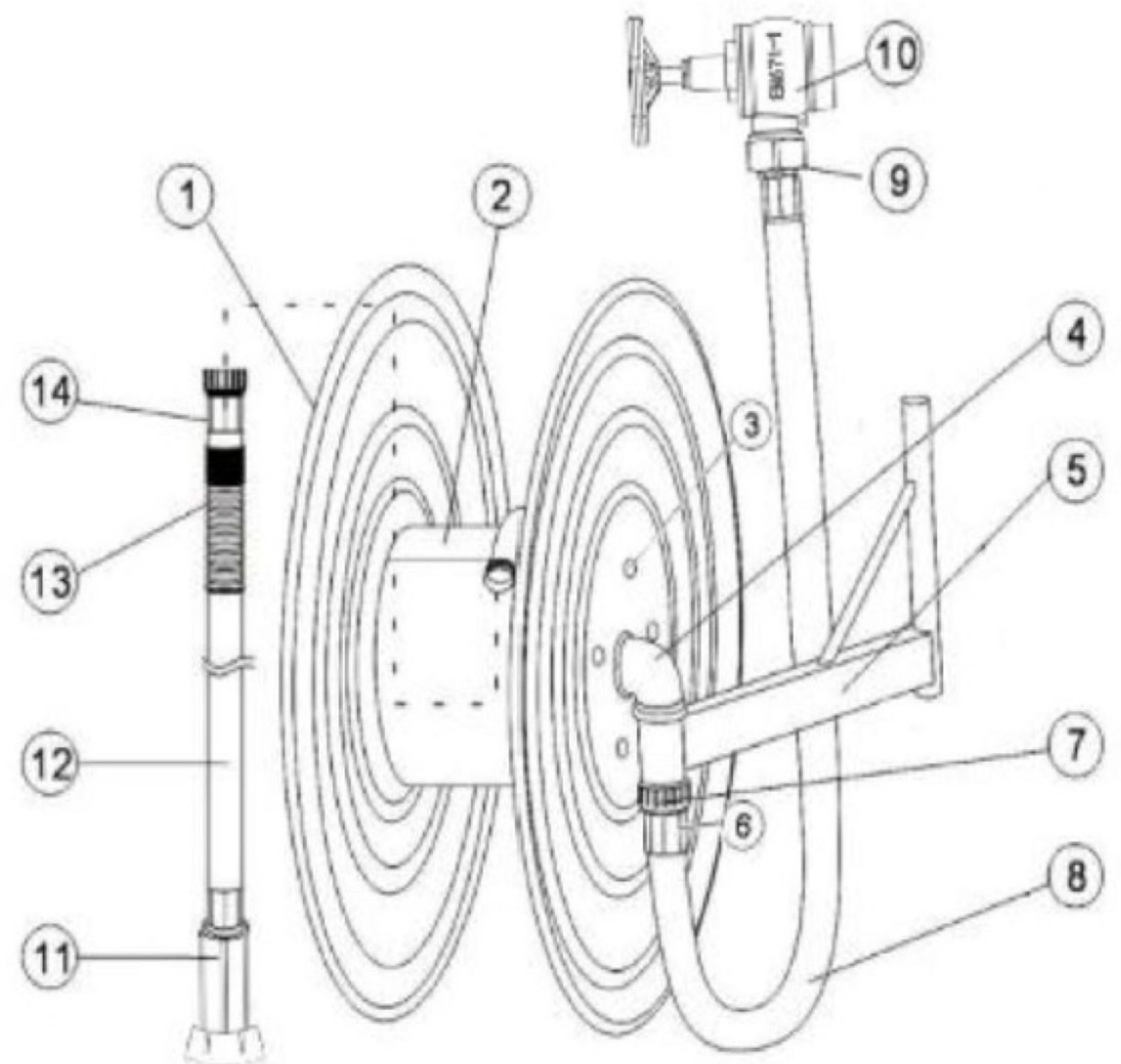

- SWINGING MANUAL HOSE REEL ASSY

● PARTS NAME

- ① HOSE REEL DISC ② HUB ③ LONG SCREW ROD ④ MANUAL WATERWAY ⑤ SWINGING ARM
⑥ CRIMPING SLEEVE ⑦ INLET JOINT ⑧ INLET HOSE ⑨ CONNECTOR ⑩ ANGLE VALVE 1.5"-1" A-4 MODEL
⑪ NOZZLE N-04-2 ⑫ FIRE HOSE 25*30MTR ⑬ PROTECTIVE SPRING ⑭ OUTLET JOINT

● FEATURES

- FULL BRASS WATERWAY WHICH WILL NEVER ROT. WE USE NIPPLES NOT HOSE CLAMPS, TO FILL IN THE INTERFACE BETWEEN HOSE AND WATERWAY. ONCE BEING SCREWED TIGHTLY, NO LEAKAGE.
- HOSE REEL WITH POWDER COATED AND ANTI-ULTRAVIOLET SIDE DISCS. THERE CAN BE PRESSURE GAUGE AT THE REEL AXIS.
- HIGH PRESSURE RESISTANCE; WORKING AT 30 KG PRESSURE BUT NOT AFFECTED.
- ENDURANCE TEST ON REEL ROTATION; AFTER OVER 3000 ROTATION, HOSE REELS SHOW NO VISIBLE LEAKAGE; OUR SWINGING HOSE REELS SHALL BE ABLE TO SWING 1000 TIMES TO MINIMUM 170° AND ALSO SHOW NO VISIBLE LEAKAGE OR DAMAGE.
- HIGH PRESSURE SPRAY. THE NOZZLE CAN BE ADJUSTED TO JET/SPRAY;
- OUR HOSE REELS CAN BE ALSO USED FOR CLEANING WHEN USED FOR FIRE FIGHTING.
- FIRE HOSE WITH ANTI-AGING AND ANTI-ULTRAVIOLET FUNCTION. MAXIMUM WP. IS 12BAR. AVERAGE BP. CAN BE UP TO 45BAR.

● PRODUCT SPECIFICATION & INSTALLATION MEASUREMENT

MODEL	HOSE SPECIFICATION (MM)	DIAMETER (MM)	BRACKET LENGTH (MM)	REEL WIDTH (MM)	HOSE PRESSURE (BAR)
FG-2001R	25MM×30MTR	600	290	150	12 BAR
FGR-2001R	25MM×30MTR	600	290	150	12 BAR

● USAGE

- 1 OPEN THE VALVE
- 2 PULL HOSE TOWARDS FIRE
- 3 OPEN NOZZLE TO SPRAY/JET AND AIM AT BASE OF FIRE.
- 4 AFTER USE, CLOSE THE VALVE
- 5 DRAIN WATER FROM HOSE
- 6 REWIND THE HOSE AND CLOSE NOZZLE ⑪.



FALCON POWER

FOR SAFETY EQUIPMENT



توريد بأسعار وجودة
لا تقبل المنافسة

هاتف: 0547777503

فالكون باور السعوديه - ٦١١٢ شارع فلسطين
جده ٢٣٣٤١ - المملكة العربية السعوديه

E-Mail: Info@falconpower.sa
Web: www.falconpower.sa

Falcon Power Saudi Arabia 6112 palestine Street
Jeddah 23341 - Kingdom of Saudi Arabia