



شركة المصنع السعودي لأجهزة الإطفاء
SAUDI FACTORY FOR FIRE EQUIPMENT Co.



Suitable to use at Fire Class:



A Solid matters forming glowing residues.
e.g. wood, rubber (car tires), paper,
textiles.



B Liquid combustible matter
e.g. petrol, oils, grease, ether,
alcohol.

FOAM / WATER CABINETS

Model: SF9000

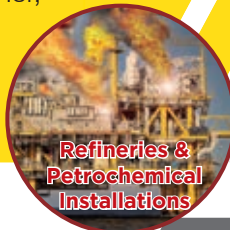

Refineries &
Petrochemical
Installations



Fuel Storage
Tanks



Helicopter
Landing
Areas



Chemical
Plants



We are very proud to be a vital part of the development of Saudi Arabia and Middle East since **1983** in fire protection industry.

General Description:

SFFECO Foam/Water Cabinet Model SF/9000 characterized for its high performance for attacking class A and B Fire within seconds. Designed for single man operation. Highly efficient in gas stations, petro-chemical plants, industrial premises, warehouses and in any area, requires protection from class A and B fires.

- ❖ Cabinet and door leaves are made of electro-galvanized steel sheet with a thickness of 1.2 mm. Optional Stainless Steel cabinets are available as per customer requirements.
- ❖ Cabinets are with all around folded edges without any sharp edges and burrs. The roof is sloped type.
- ❖ Cabinet painted with Powder Coated for elegant finish and protection from rust.
- ❖ Operating instructions are silk screen printed in English and Arabic inside the cabinet doors.

Cabinet Components:

Fire Hose Reel



Superior quality, 100% synthetic jacket hose, the outer fabric is made of circular woven synthetic fiber and root proof yarn, while inner layer is a substance of tropical rubber applied by means of a special vulcanizing technique ensures long life, elasticity and flexibility. Hose size 1.5 inch x 30 meter length, wrapped on swinging hose reel.

Hose reel is made of 1mm mild steel sheet and pressed out. The outer edge of the reel is rolled over to give a safe handling edge on the outer rims. The reel is mounted on swinging arm.

Foam Proportioner



2" Foam proportioner or inductor. The design of the inductor enables an exact mixing rate of the passing water equipped with bypass system.

Foam Can



Two canisters of 20 liter 3% foam concentrate. Different types of foam concentrates are available on request.

Foam Branch Pipe



Foam branch pipe with shut off control valve, body made of aluminum and handle with hard rubber. It can throw foam between 15-20 meter depends on line pressure. Also it can be used as water jet pipe.

Angle Valve

Size: 1.5"



CABINET Selection

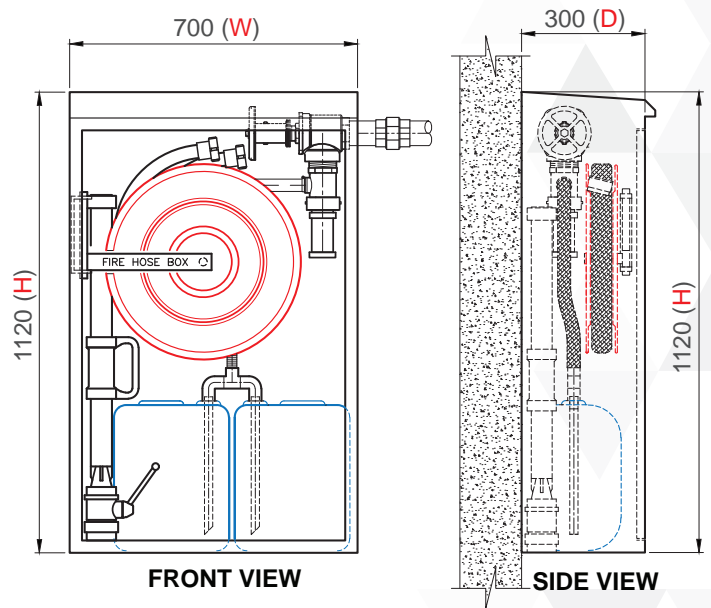
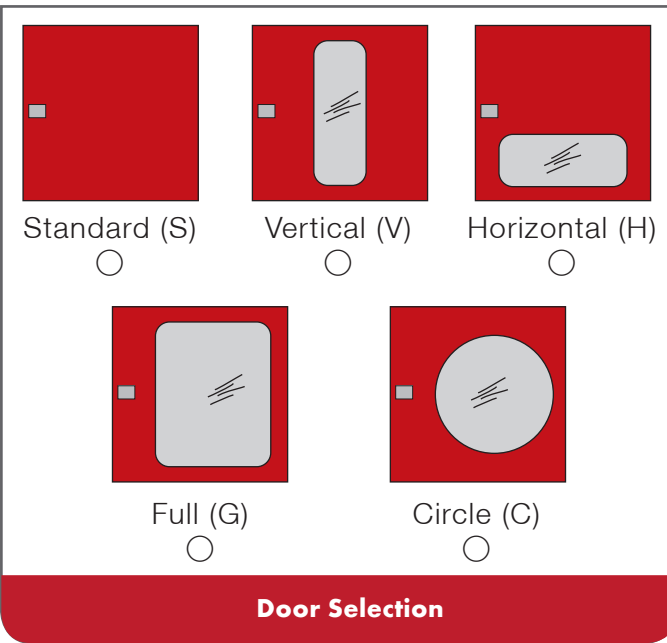
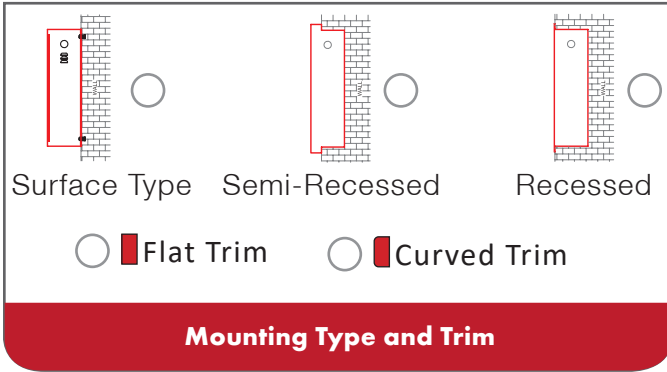
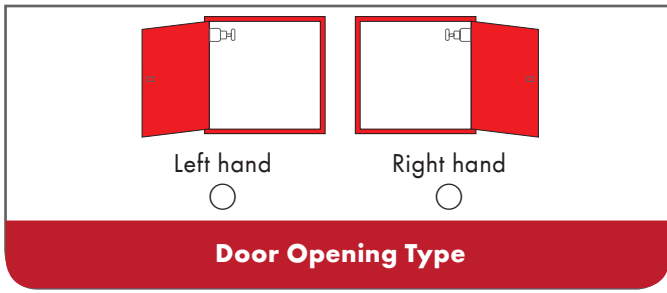

Model	H (MM)	W (MM)	D (MM)
SF9000	1120 (Sloped Roof)	700	300

Note: We are fully capable to manufacture any type of foam cabinets as per customer designs or specifications.

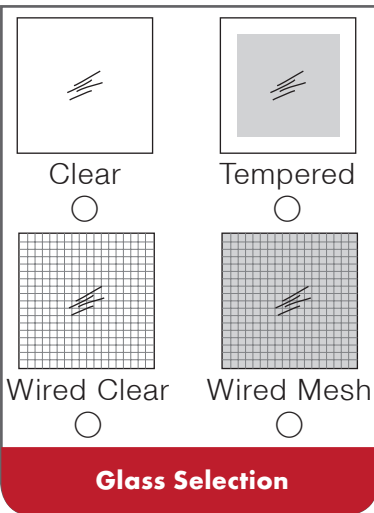

Door, Frame & Backbox in Stainless Steel (Full Stainless Steel)
 Hairline Finish Mirror Finish

Door, Frame & Backbox in EGS (Full Electro Galvanized Steel)
 Red Color _____

Backbox in Electro Galvanized Steel
 Red Color _____

Door & Frame in Stainless Steel
 Hairline Finish Mirror Finish

Cabinet Material & Finish

Note:

SFFECO HAS A LONG STANDING ESTABLISHED REPUTATION FOR PIONEERING INNOVATION EVER SINCE ITS FOUNDATION IN 1983.

SFFECO HAS ITS STATE-OF-THE-ART MANUFACTURING PLANTS IN RIYADH AND DUBAI PRODUCING END-TO-END RANGE OF PRODUCTS FOR THE FIRE FIGHTING INDUSTRY MATCHING INTERNATIONAL STANDARDS IN QUALITY.



شركة المصنع السعودي لأجهزة الإطفاء SAUDI FACTORY FOR FIRE EQUIPMENT Co.

FACTORY & HEAD OFFICE - RIYADH

2nd Industrial Area, Al-Kharj Road, Riyadh, KSA, P.O. Box 58469, Riyadh 11515
Tel : +966 11 2650070, Fax +966 11 2652190, E-mail: riadh@sffeco.com

SFFECO GLOBAL - DUBAI

P.O. Box 261318, FZA South, Dubai U.A.E.
Tel: +971 4 880 9890, Fax +971 4 880 9822, E-mail: sales@sffecoglobal.com

JEDDAH BRANCH

P.O. Box: 16769, Jeddah – 21474, KSA
Tel : +966 12 670 6009,
Fax +966 12 676 0307
E-mail: jeddah@sffeco.com

DAMMAM BRANCH

P.O. Box: 7162, Dammam – 31462, KSA
Tel : +966 13 8351961,
Fax +966 13 8351968
E-mail: dammam@sffeco.com

MADINAH BRANCH

Tel : 0148660959, 0148283256,
Fax 0148660969
E-mail: madinah@sffeco.com

