

BRISTOL

TECHNICAL SUBMITTAL

FIRE PUMP SET
HORIZONTAL END SUCTION
(500 GPM @ 8 BAR)
BRISTOL UL/FM PUMP

CONTRACTOR
AZEEDAK - KSA



Fire Fighting Solutions Provider

ص.ب: ٧٤٥٨٢ , دبي الامارات العربية المتحدة تيلفون : ٣٤٧٧٠٧٣ / ٣٤٧٢٤٢٦ ء ٩٧١ فاكس : ٣٤٧٢٣٦٣ ء ٩٧١

TECHNICAL SUBMITTAL FIRE PUMP

Rev	Description	Prepared by	Checked	Approved	Date
0	Issued for Approval	MANICKAM	Nasser Mansour	Nasser Mansour	30-05-2023

Fire Fighting Solutions Provider

ص.ب: ٧٤٥٨٢، دبي الامارات العربية المتحدة تيلفون: ٣٤٧٧٠٧٣ / ٣٤٧٢٤٢٦ +٩٧١ ٤ ٣٤٧٢٣٦٣ فاكس: +٩٧١ ٤ ٣٤٧٢٣٦٣

P.O.Box: 74582 Dubai, UAE. Tel : +971 4 3472426 / 3477073 Fax : +971 4 3472363 E-mail: sales@bristol-fire.com, www.bristol-fire.com

EQUIPMENT DESCRIPTION

Fire Fighting Solutions Provider

ص.ب: ٧٤٥٨٢ . دبي الامارات العربية المتحدة تيلفون : ٣٤٧٧٠٧٣ / ٣٤٧٢٤٢٦ +٩٧١ ٤ ٣٤٧٢٣٦٣ فاكس : +٩٧١ ٤ ٣٤٧٢٣٦٣

P.O.Box: 74582 Dubai, UAE. Tel : +971 4 3472426 / 3477073 Fax : +971 4 3472363 E-mail: sales@bristol-fire.com, www.bristol-fire.com

BRISTOL	Vendor Ref. No SO-24630	Doc. Seq. No 02	Revision No 0
	Vendor Doc. No BFV-ED		Date: 30-05-2023
Contractor Name: AZEEDAK - KSA			
Project Name: FIRE FIGHTING PUMP SET - 500 GPM @ 8 BAR			

<u>ITEM</u>	<u>DESCRIPTION</u>	<u>QTY</u>
A	<u>DIESEL FIRE PUMP</u>	
	Q = 500 GPM H = 8 BAR	1
	BRISTOL UL/FM pump model IS 80-260 Horizontal end suction, complete with:	
	1. Diesel engine CLARKE Model JU4H-UF14, 71HP, 3000RPM, dual lead acid batteries, Muffler	
	2. Automatic diesel pump controller arranged for 12 V, NEMA2	
	3. Accessories:	
	• Suction and discharge gauge	2
A1	<u>MAIN ACCESSORIES</u>	
	a. Fuel Tank with 70gal and direct reading fuel gauge	1
	b. Flow meter GERAND venture type model G-500-6" Grooved ends.	1
B	<u>ELECTRIC FIRE PUMP</u>	
	Q = 500 GPM H = 8 BAR	1
	BRISTOL UL/FM pump model IS 100-260 Horizontal end suction, complete with:	
	1. Electric motor 100 HP at 2P, ODP enclosure 50°C ambient, Class F insulation, 1.15 service factor, 3/60/380 V.	
	2. Automatic electric pump controller, suitable for 100HP, 3/60/380 V , Y-Delta, NEMA 2.	
	3. Accessories:	
	• Suction and discharge gauge	2
	• Casing relief valve	1
C	<u>JOCKEY PUMP</u>	
	Q = 15 GPM H = 8.7 BAR	1
	Bristol / RV or Zirantec Vertical Multistage pump, complete with:	
	1. Electric motor 2P, 3PH/60HZ/380V , TEFC enclosure	
	2. Automatic jockey pump controller 380V , NEMA 2	

SUB-VENDORS LIST

Fire Fighting Solutions Provider

ص.ب: ٧٤٥٨٢ , دبي الامارات العربية المتحدة تيلفون : ٣٤٧٧٠٧٣ / ٣٤٧٢٤٢٦ ء ٩٧١ ء ٣٤٧٢٣٦٣ فاكس : ٩٧١ ء ٣٤٧٢٣٦٣

P.O.Box: 74582 Dubai, UAE. Tel: +971 4 3472426 / 3477073 Fax: +971 4 3472363 E-mail: sales@bristol-fire.com, www.bristol-fire.com

BRISTOL	Vendor Ref. No SO-24630	Doc. Seq. No 02	Revision No 0
	Vendor Doc. No BFV-ED		Date: 30-05-2023
Contractor Name: AZEEDAK - KSA			
Project Name: FIRE FIGHTING PUMP SET - 500 GPM @ 8 BAR			

SUB-VENDORS LIST

- 1 *Diesel engine* : CLARKE
- 2 *Diesel controller* : TORNATECH
- 3 *Electric Motor* : US-NIDEC/WEG/MARATHON
- 4 *Electric Controller* : TORNATECH
- 5 *Jockey Pump* : RV/ZIRANTECH
- 6 *Jockey Controller* : TORNATECH
- 7 *Casing Relief Valve* : SS
- 8 *Gauges* : FACTORY CHOICE
- 9 *Flow Meter* : GERAND

DIESEL FIRE PUMP DATA SHEET AND CURVE

Fire Fighting Solutions Provider

ص.ب: ٧٤٥٨٢ . دبي الامارات العربية المتحدة تيلفون: ٣٤٧٧٠٧٣ / ٣٤٧٢٤٢٦ ء ٩٧١ ء ٣٤٧٢٣٦٣ فاكس: ٩٧١ ء ٣٤٧٢٣٦٣

P.O.Box: 74582 Dubai, UAE. Tel : +971 4 3472426 / 3477073 Fax : +971 4 3472363 E-mail: sales@bristol-fire.com, www.bristol-fire.com

BRISTOL



FIRE PUMPS

HORIZONTAL SPLIT CASE, END SUCTION, VERTICAL TURBINE,
CONTAINERIZED PUMP, PACKAGED FIRE PUMP, FUEL TANK & ANTI-VORTEX PLATE





END SUCTION TYPE



Description

Are designed according to NFPA 20 for firefighting applications. This pump is designed with latest technology and has premium components for easy maintenance and absolute efficiency .

Features

- Available in electric motor driven or engine driven configuration
- UL File No. : EX16459
- Dynamically balanced impellers

Performance Range

- Capacity : From 50 GPM up to 1000 GPM
- Head : From 50 MTR up to 209 MTR

Pump Dimensions

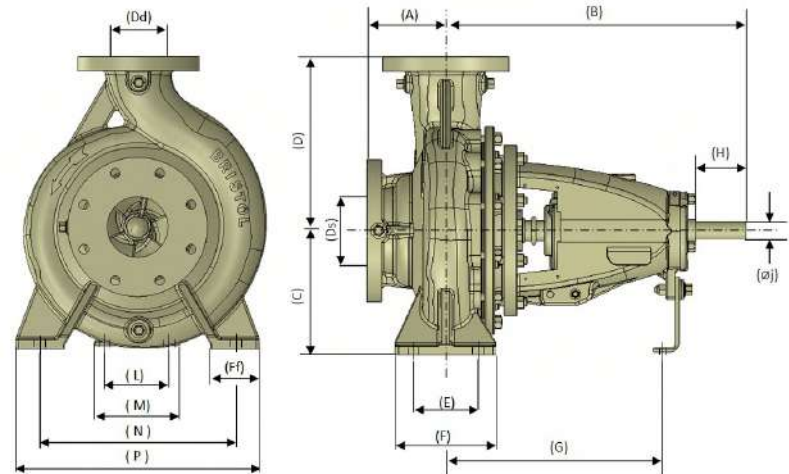

MODEL	A	B	C	D	E	F	Ff	G	H	L	M	N	P	Ø j	keyway
IS32 - 200	80	360	160	183.5	70	100	50	267	49	110	140	190	240	22.2	4.7X4.7X32
IS32 - 260	100	360	180	228	95	125	65	267	49	110	140	250	320	22.2	4.7X4.7X32
IS50 - 320H	125	470	225	285.6	95	125	65	342	79.4	110	140	280	345	28.5	6.35X6.35X44.5
IS65 - 320H	125	470	225	280	120	160	80	342	79.4	110	140	315	400	28.5	6.35X6.35X44.5
IS80 - 260	125	470	200	280	120	160	80	342	79.4	110	140	315	400	28.5	6.35X6.35X44.5
IS80 - 320H	125	470	250	317.4	120	160	80	342	79.4	110	140	315	400	28.5	6.35X6.35X44.5
IS100 - 260	140	470	225	280	120	160	80	342	79.4	110	140	315	400	28.5	6.35X6.35X44.5
IS100 - 320H	142	470	250	316	120	160	80	342	79.4	110	140	315	400	28.5	6.35X6.35X44.5
BEP 3X2.5LP	105	465	180	225	95	125	65	337	80	110	140	250	320	32	6X6X35
BEP 4X3LP	125	470	180	250	95	125	65	342	80	110	140	280	345	32	8X8X56



End Suction Pump Flange Details

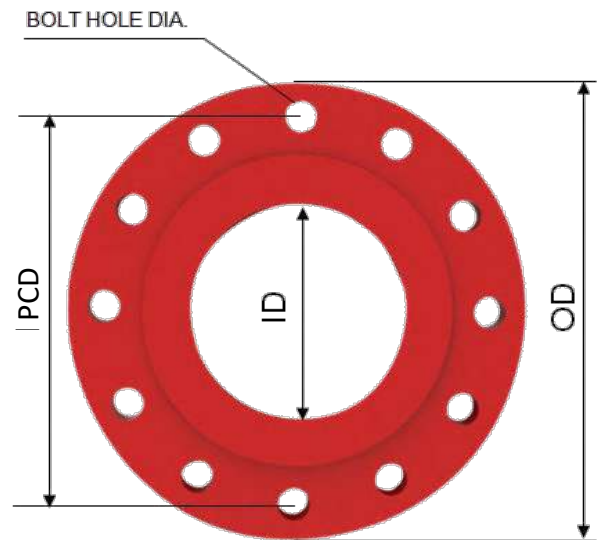

Model	Suction					Discharge				
	ID	(Pump Casing Range) OD	No. of Holes	Bolt Hole DIA	PCD	ID	(Pump Casing Range) OD	No. of Holes	Bolt Hole DIA	PCD
IS32-200	50	165	4	5/8"-11UNC-2B	120.7	32	140	4	1/2"-13UNC-2B	88.9
IS32-260	50	165	4	5/8"-11UNC-2B	120.7	32	140	4	1/2"-13UNC-2B	88.9
IS50-320H	65	185	4	5/8"-11UNC-2B	139.7	50	165	4	5/8"-11UNC-2B	120.7
IS65-320H	80	200	4	5/8"-11UNC-2B	152.4	65	185	4	5/8"-11UNC-2B	139.7
IS80-260	100	229	8	5/8"-11UNC-2B	190.5	80	200	4	5/8"-11UNC-2B	152.4
IS80-320H	100	229	8	5/8"-11UNC-2B	190.5	80	200	4	5/8"-11UNC-2B	152.4
IS100-260	125	254	8	3/4"-10UNC-2B	215.9	100	229	8	5/8"-11UNC-2B	190.5
IS100-320H	125	254	8	3/4"-10UNC-2B	215.9	100	229	8	5/8"-11UNC-2B	190.5
BEP 3X2.5LP	80	200	8	18	158.75	65	190.5	4	18	150
BEP 4X3LP	100	220	8	18	181	80	200	8	18	158.75

* Standard for Cast Iron Flanged Fittings : ANSI / ASME B16.1

* Standard for Ductile Iron Flanged Fittings : ANSI/ASME B16.42

End Suction Pump Components

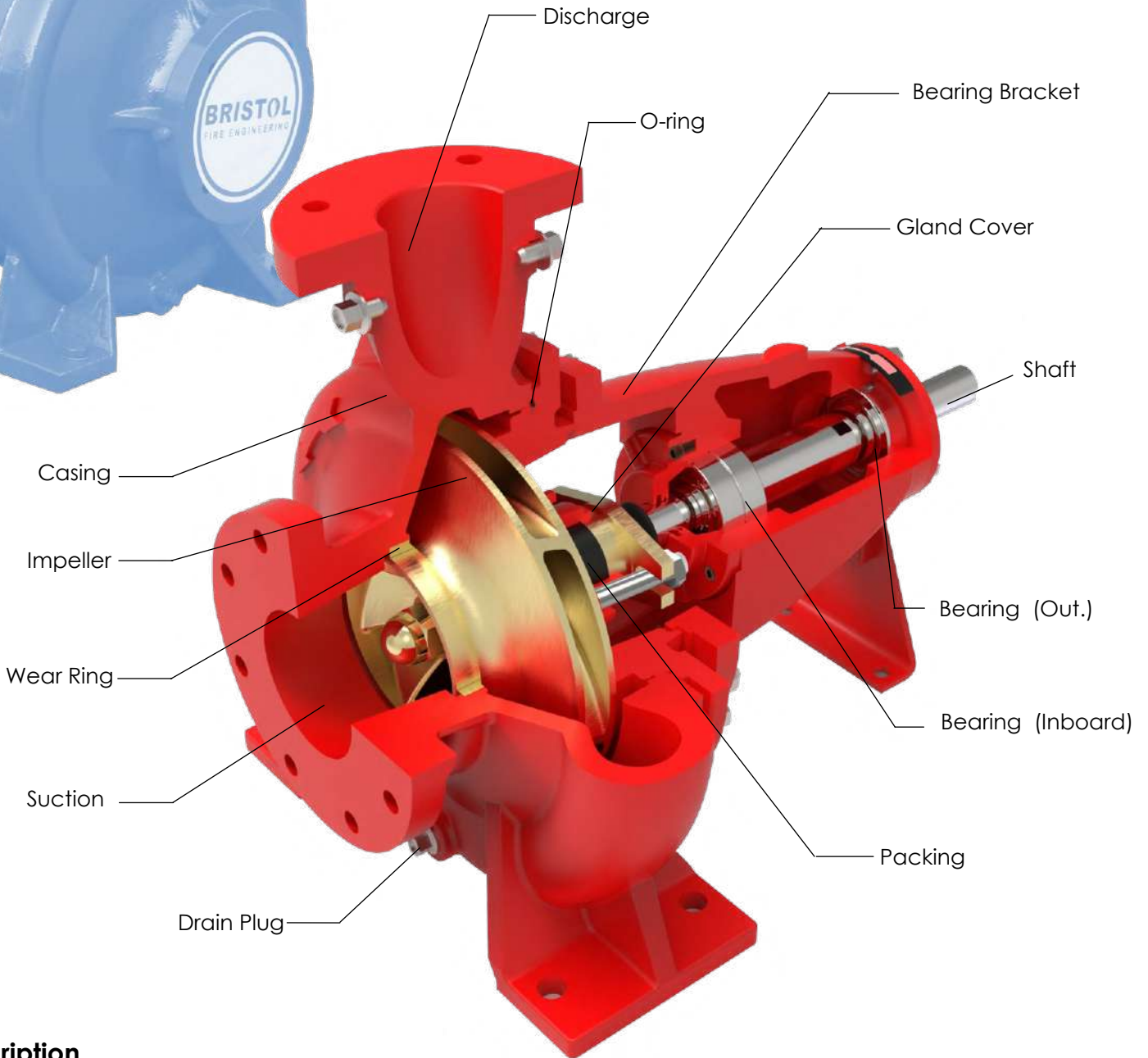

Description

Casing - Ductile Iron 65-45-12 - Heavy-duty power frame

Impeller - Bronze / SS304

Wear Ring - Bronze is standard for the certified ANSI pumps radially split casing with flange connection

Suction - Horizontal End Suction ANSI 150# or 300# flange drilling is available based on material selection

Discharge - Vertical Centreline Discharge

Bearing Bracket - Ductile Iron 65-45-12 - Heavy-duty power frame

Gland Cover - Bronze - to house a gland seal

Shaft - Stainless Steel - Sleeve shaft as standard for extended seal life

Bearing (Out.) - Deep Grooved Ball Bearing

Bearing (Inb.) - Deep Grooved Ball Bearing

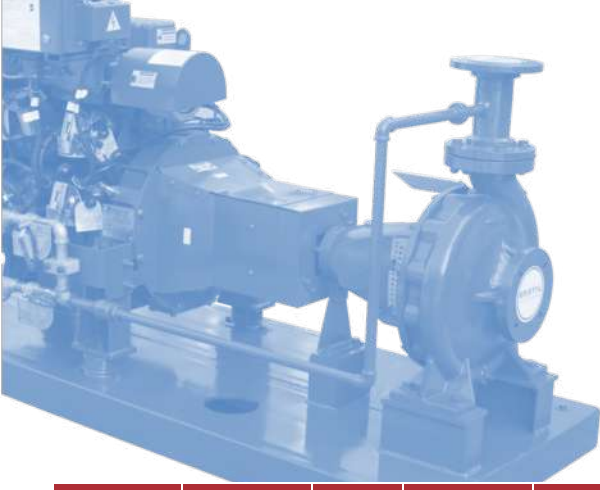

End Suction Pump Selection Chart



Model	Rated Capacity (GPM)	Size (In)	UL Listed Pressure (PSI)	FM Approved Pressure (PSI)	Rated Speed (RPM)
IS32-200	50	2 x 1 1/4	55-85		2800
IS32-200	50	2 x 1 1/4	62-95		2950
IS50-320H	50	2 1/2 x 2	88-142		2400
IS50-320H	50	2 1/2 x 2	103-167		2600
IS32-260	50	2 x 1 1/4	113 - 130		2950
BEP 3X2.5 LP	100	3 x 2 1/2	60-92		2950
BEP 3X2.5 LP	100	3 x 2 1/2	62-95		3000
IS50-320H	100	2 1/2 x 2	87-141		2400
BEP 3X2.5 LP	100	3 x 2 1/2	87-134		3550
IS50-320H	100	2 1/2 x 2	102-166		2600
IS32-260	100	2 x 1 1/4	103 - 125		2950
IS65-260	100	3 x 2 1/2	110-148		2950
IS65-260	100	3 x 2 1/2	113-153		3000
IS50-320H	100	2 1/2 x 2	119-189		2800
IS50-320H	100	2 1/2 x 2	132-210		2950
IS50-320H	100	2 1/2 x 2	178-298		3500
BEP 3X2.5 LP	150	3 x 2 1/2	59-91		2950
BEP 3X2.5 LP	150	3 x 2 1/2	61-94		3000
IS50-320H	150	2 1/2 x 2	84-140		2400
BEP 3X2.5 LP	150	3 x 2 1/2	86-132		3550
IS50-320H	150	2 1/2 x 2	99-165		2600
IS65-260	150	3 x 2 1/2	110-148		2950
IS65-260	150	3 x 2 1/2	113-153		3000
IS50-320H	150	2 1/2 x 2	118-188		2800
IS50-320H	150	2 1/2 x 2	132-209		2950
IS50-320H	150	2 1/2 x 2	177-296		3500
BEP 3X2.5 LP	200	3 x 2 1/2	58-90		2950
BEP 3X2.5 LP	200	3 x 2 1/2	60-93		3000
BEP 3X2.5 LP	200	3 x 2 1/2	85-130		3550
IS65-320H	200	3 x 2 1/2	88-133		2400
IS65-320H	200	3 x 2 1/2	97-181		2800
IS65-320H	200	3 x 2 1/2	104-158		2600
IS65-320H	200	3 x 2 1/2	108-201		2950
IS65-260	200	3 x 2 1/2	109-147		2950
IS65-260	200	3 x 2 1/2	113-152		3000
IS50-320H	200	2 1/2 x 2	113-188		2800
IS50-320H	200	2 1/2 x 2	127-209		2950
IS65-320H	200	3 x 2 1/2	159-290		3500
IS50-320H	200	2 1/2 x 2	173-296		3500
IS80-260	200	4 x 3		111-151	2950
IS80-260	200	4 x 3		115-157	3000
BEP 3X2.5 LP	250	3 x 2 1/2	55-88		2950
BEP 3X2.5 LP	250	3 x 2 1/2	57-91		3000
BEP 3X2.5 LP	250	3 x 2 1/2	83-129		3550
IS65-320H	250	3 x 2 1/2	85-131		2400
IS65-320H	250	3 x 2 1/2	97-181		2800
IS65-320H	250	3 x 2 1/2	102-155		2600
IS65-260	250	3 x 2 1/2	107-146		2950
IS65-320H	250	3 x 2 1/2	107-201		2950
IS65-260	250	3 x 2 1/2	111-151		3000
IS65-320H	250	3 x 2 1/2	157-290		3500
BEP 3X2.5 LP	300	3 x 2 1/2	52-85		2950
BEP 3x2.5 LP	300	3 x 2 1/2	54-88		3000
BEP 4x3 LP	300	4 x 3	55-89		2950
BEP 4x3 LP	300	4 x 3	57-92		3000
BEP 3X2.5 LP	300	3 x 2 1/2	80-126		3550
IS65-320H	300	3 x 2 1/2	82-128		2400
BEP 4x3 LP	300	4 x 3	82-130		3550
IS65-320H	300	3 x 2 1/2	97-181		2800
IS65-320H	300	3 x 2 1/2	98-152		2600
IS65-260	300	3 x 2 1/2	105-144		2950

Model	Rated Capacity (GPM)	Size (In)	UL Listed Pressure (PSI)	FM Approved Pressure (PSI)	Rated Speed (RPM)
IS65-320H	300	3 x 2 1/2	107-201		2950
IS65-260	300	3 x 2 1/2	109-149		3000
IS80-320H	300	4 x 3	143-183		2800
IS65-320H	300	3 x 2 1/2	155-289		3500
IS80-320H	300	4 x 3	159-203		2950
IS80-260	300	4 x 3	167-222	153-206	3550
IS80-260	300	4 x 3		111-150	2950
IS80-260	300	4 x 3		115-156	3000
BEP 4X3 LP	400	4 x 3	54-87		2950
BEP 4X3 LP	400	4 x 3	56-90		3000
BEP 4X3 LP	400	4 x 3	79-127		3550
IS100-320H	400	5 x 4	83-147		2400
IS65-260	400	3 x 2 1/2	99-141		2950
IS100-320H	400	5 x 4	98-172	118-168	2600
IS65-260	400	3 x 2 1/2	103-146		3000
IS80-260	400	4 x 3	105-139	110-149	2950
IS80-260	400	4 x 3	109-144	114-154	3000
IS100-320H	400	5 x 4	110-142		2800
IS100-320H	400	5 x 4	123-158	122-236	2950
IS100-320H	400	5 x 4	133-163	126-244	3000
IS80-320H	400	4 x 3	142-183		2800
IS80-320H	400	4 x 3	158-203		2950
IS80-260	400	4 x 3	165-222	152-206	3550
BEP 4X3 LP	450	4 x 3	53-85		2950
BEP 4X3 LP	450	4 x 3	55-88		3000
BEP 4X3 LP	450	4 x 3	78-126		3550
IS100-320H	450	5 x 4	83-147		2400
IS100-320H	450	5 x 4	98-172		2600
IS100-320H	450	5 x 4	110-142		2800
IS100-320H	450	5 x 4	122-158		2950
IS100-320H	450	5 x 4	133-164		3000
IS80-320H	450	4 x 3	140-182		2800
IS80-320H	450	4 x 3	157-203		2950
BEP 4X3 LP	500	4 x 3	51-84		2950
BEP 4X3 LP	500	4 x 3	53-87		3000
BEP 4X3 LP	500	4 x 3	78-125		3550
IS100-320H	500	5 x 4	82-147		2400
IS100-320H	500	5 x 4	97-172	116-168	2600
IS80-260	500	4 x 3	101-137	108-146	2950
IS80-260	500	4 x 3	106-142	112-152	3000
IS100-320H	500	5 x 4	110-142		2800
IS100-320H	500	5 x 4	122-226	121-235	2950
IS100-320H	500	5 x 4	124-234	125-244	3000
IS80-320H	500	4 x 3	136-182		2800
IS100-260	500	5 x 4	144-212	134-197	3550
IS80-320H	500	4 x 3	155-202		2950
BEP 5X4 HH	500	5 x 4	155-244		2950
IS80-260	500	4 x 3	163-220	150-204	3550
IS100-320H	750	5 x 4	89-166	111-166	2600
IS100-320H	750	5 x 4	104-131		2800
IS100-260	750	5 x 4	113-139	111-143	2950
IS100-260	750	5 x 4	118-144	115-149	3000
IS100-320H	750	5 x 4	119-224	119-233	2950
IS100-320H	750	5 x 4	119-232	123-241	3000
IS100-260	750	5 x 4	140-212	134-195	3550
BEP 5X4 HH	750	5 x 4	149-239		2950
IS100-260	1000	5 x 4	104-131	109-141	2950
IS100-260	1000	5 x 4	109-137	113-146	3000
IS100-260	1000	5 x 4	132 - 208	130-194	3550
BEP 5X4 HH	1000	5 x 4	140-231		2950

BRISTOL

Model/Stage IS 80-260

Design Pressure/Head 116.00 psi

Design Flow 500.00 GPM

Rated Speed 2,950 rpm

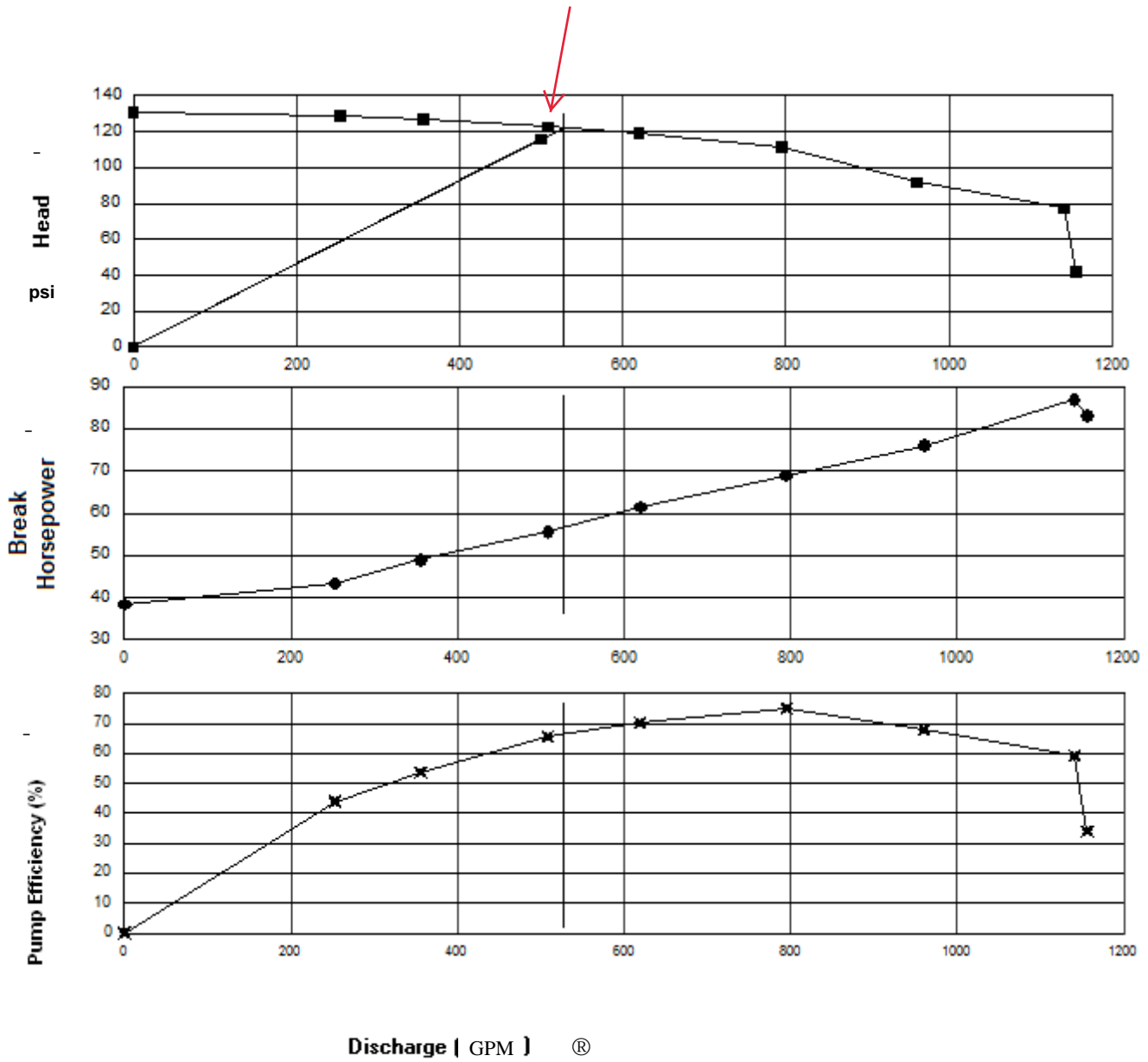

DIESEL FIRE PUMP ENGINE DATA

Fire Fighting Solutions Provider

ص.ب: ٧٤٥٨٢ . دبي الامارات العربية المتحدة تيلفون : ٣٤٧٧٠٧٣ / ٣٤٧٢٤٢٦ ء ٩٧١ ء ٣٤٧٢٣٦٣ فاكس : ٩٧١ ء ٣٤٧٢٣٦٣

P.O.Box: 74582 Dubai, UAE. Tel : +971 4 3472426 / 3477073 Fax : +971 4 3472363 E -mail: sales@bristol-fire.com, www.bristol-fire.com

UK Purchased

FM-UL-cUL APPROVED RATINGS KW/BHP

JU4H MODEL	RATED SPEED													
	1470		1760		2100		2350		2600		2800		3000	
UF04							37	50	41	55	45	60	45	60
UF10			31	41	38	51	41	55						
UF12							41	55	44	59				
UF14							41	55	44	59	52	70	53	71
UF20			45	60	50	67	54	72						
UF22							54	72	56	75				
UF24							54	72	56	75	60	80	62	83
UF34							63	85	63	85	78	104	86	115
UFH0			54	73	66	88	73	98						
UFH2							73	98	74	99				
UF40			70	94	78	105	79	106						
UF42							79	106	79	106				
UF50	59	79	82	110	97	130	95	127						
UF52							95	127	95	127				
UF54							91	122	104	139	108	145	108	145



Picture shown represents a JU4H-NA engine model

SPECIFICATIONS

ITEM	JU4H MODELS					
	UF04/10/12/14	UF20/22/24	UF34	UFH0/H2	UF40/42	UF50/52/54
Number of Cylinders	4					
Aspiration	NA			T		
Rotation*	CW					
Overall Dimensions – mm (in.)	989 (39) H x 1226 (48) L x 916 (36.1) W			1166 (45.9) H x 1357 (53.4) L x 934 (36.8) W		
Crankshaft Centerline Height – mm (in.)	356 (14)					
Weight – kg (lb)	413 (910)			424 (935)		
Compression Ratio	17.6:1			17.0:1		
Displacement – l (cu. in.)	4.5 (275)					
Engine Type	4 Stroke Cycle – Inline Construction					
Bore & Stroke – mm (in.)	106 x 127 (4.19 x 5.00)					
Installation Drawing	D545					
Wiring Diagram AC	C07651					
Wiring Diagram DC	C072145					
Engine Series	John Deere 4045 Series					

Abbreviations: CW – Clockwise NA – Naturally Aspirated T – Turbocharged L - Length W – Width H - Height

*Rotation viewed from Heat Exchanger / Front of engine

CERTIFIED POWER RATING

- Each engine is factory tested to verify power and performance.
- Although FM-UL ratings are shown at specific speeds, Clarke engines can be applied at any intermediate speed. To determine the intermediate speed power; make a linear interpolation from the Clarke FM-UL power curve. Contact Clarke or your Pump OEM Representative to obtain details.

ENGINE RATINGS BASELINES

- Engines are to be used for stationary emergency standby fire pump service only. Engines are to be tested in accordance with NFPA 25.
- Engines are rated at standard SAE conditions of 29.61 in. (752.1 mm) Hg barometer and 77°F (25°C) inlet air temperature [approximates 300 ft. (91.4 m) above sea level] by the testing laboratory (see SAE Standard J 1349).
- A deduction of 3 percent from engine horsepower rating at standard SAE conditions shall be made for diesel engines for each 1000 ft. (305 m) altitude above 300 ft. (91.4 m)
- A deduction of 1 percent from engine horsepower rating as corrected to standard SAE conditions shall be made for diesel engines for every 10°F (5.6°C) above 77°F (25°C) ambient temperature.



ENGINE EQUIPMENT

EQUIPMENT	STANDARD	OPTIONAL
Air Cleaner	Direct Mounted, Washable, Indoor Service with Drip Shield	Disposable, Drip Proof, Indoor Service Outdoor Type, Single or Two Stage (Cyclonic)
Alarms	Overspeed Alarm & Shutdown, Low Oil Pressure, Low & High Coolant Temperature, Low Raw Water Flow, High Raw Water Temperature	Low Coolant Level, Low Oil Level, Oil Filter Differential Pressure, Fuel Filter Differential Pressure, Air Filter Restriction
Alternator	12V-DC, 42 Amps; with Poly-Vee Belt and Guard	24V-DC, 40 Amps; with Belt Guard
Coupling	Bare Flywheel	Listed Driveshaft and Guard, UF10/12/14, UF20/22/24 – CDS10-SC; UFH0/H2, UF40/42 – CDS20-SC; UF50/52/54 – CDS30-S1
Engine Heater	230V-AC, 1000 Watt	115V-AC, 1000 Watt
Exhaust Flex Connection	For NA Engines - SS, Clamped, 3" For T Engines – SS, Clamped, 4"	SS Flex, Clamped, 4" & 5"
Exhaust Protection	Blankets on Naturally Aspirated Models, Metal Guards on Manifolds and Turbocharger on Turbocharged Models	
Flywheel Housing	SAE #3	
Flywheel Power Take Off	11.5" SAE Industrial Flywheel Connection	
Fuel Connections	Fire Resistant, Flexible, USA Coast Guard Approved, Supply and Return Lines	
Fuel Filter	Primary Filter with Priming Pump	
Fuel Injection System	Stanadyne, Direct Injection	
Fuel Solenoid	12V-DC Energized to Stop (ETS)	12V-DC Energized to Run (ETR); 24V-DC Energized to Run (ETR); 24V-DC Energized to Stop (ETS)
Governor, Speed	Constant Speed, Mechanical	
Heat Exchanger	Tube and Shell Type, 4 BAR (60 PSI), BSP(F) Connections	Sea Water Compatible
Instrument Panel	English and Metric, Tachometer, Hourmeter, Water Temperature, Oil Pressure and Two (2) Voltmeters	
Junction Box	Integral with Instrument Panel; For DC Wiring Interconnection to Engine Controller	
Lube Oil Cooler	Engine Water Cooled, Plate Type	
Lube Oil Filter	Full Flow with By-Pass Valve	
Lube Oil Pump	Gear Driven, Gear Type	
Manual Start Control	On Instrument Panel with Control Position Warning Light	
Overspeed Control	Electronic with Reset and Test on Instrument Panel	
Raw Water Cooling Loop – w/Alarms	Galvanized	Seawater, All 316SS, High Pressure
Raw Water Cooling Loop – Solenoid Operation	Automatic from Fire Pump Controller and from Engine Instrument Panel (for Horizontal Fire Pump Applications)	Not Supplied (for Vertical Turbine Fire Pump Applications)
Run – Stop Control	On Instrument Panel with Control Position Warning Light	
Starters	Two (2) 12V-DC	Two (2) 24V-DC
Throttle Control	Adjustable Speed Control, Tamper Proof	
Water Pump	Centrifugal Type, Poly-Vee Belt Driven	

Abbreviations: DC – Direct Current, AC – Alternating Current, SAE – Society of Automotive Engineers, NA – Naturally Aspirated, T- Turbocharged, BSP(F) – British Standard Pipe Thread (Female), SS – Stainless Steel



MODEL NOMENCLATURE (8 Digit Models)

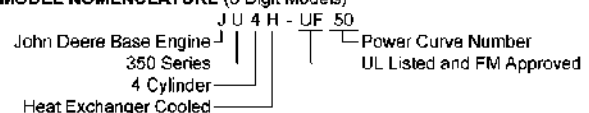

CLARKE UK, Ltd.
 Grange Works, Lomond Rd., Coatbridge, ML5-2NN
 United Kingdom
 Tel +44-1236-429946 Fax +44-1236-427274
 www.clarkefire.com

CLARKE Fire Protection Products, Inc.
 100 Progress Place, Cincinnati, Ohio 45246
 United States of America
 Tel +1-513-475-FIRE (3473) Fax +1-513-771-8930
 www.clarkefire.com

CLARKE®

FIRE PUMP MODEL: JU4H-UF14
Heat Exchanger Cooled
Naturally Aspirated
4.5L 4 Cylinder

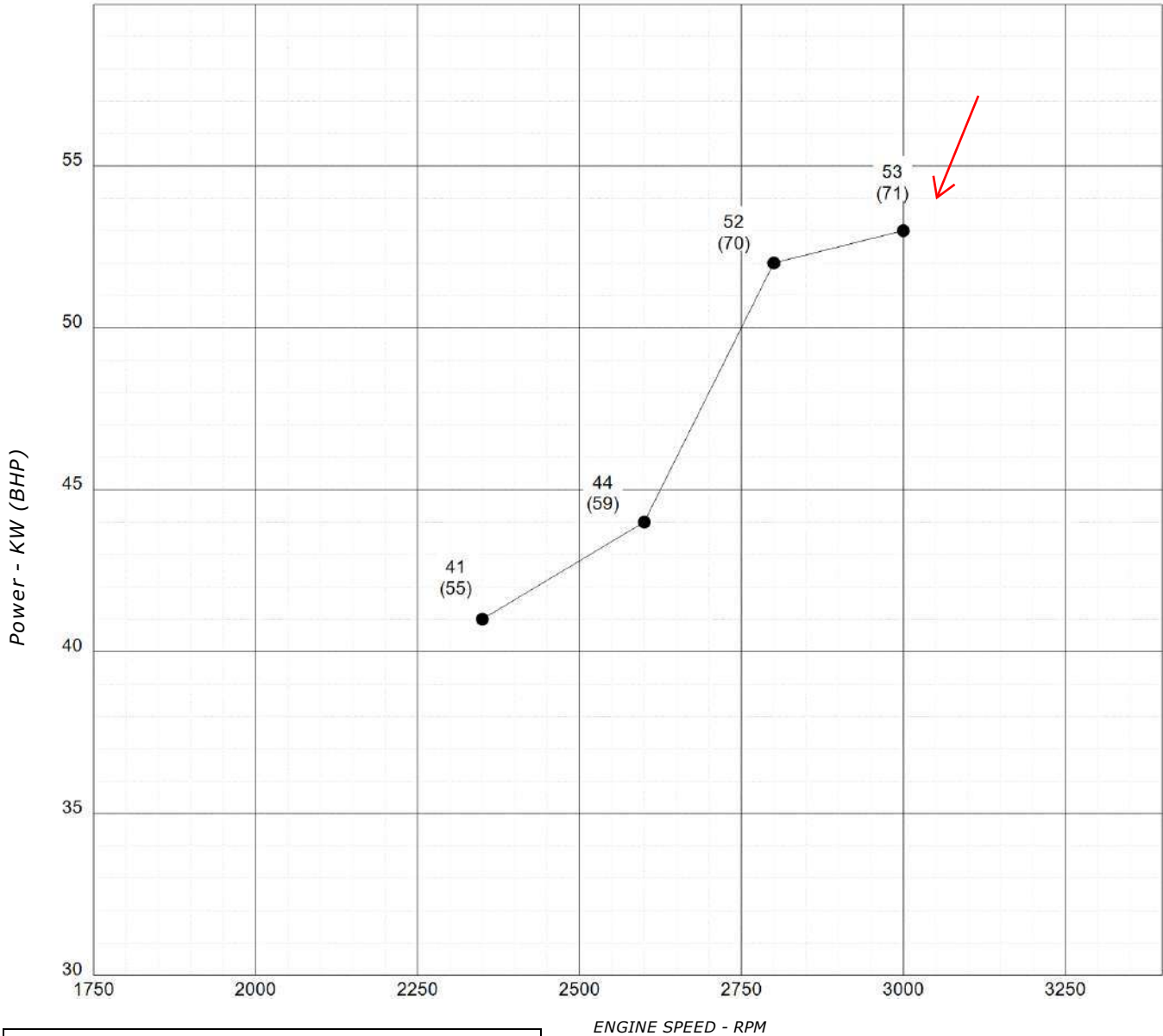

RESTRICTED:

Use only for Stand-By Fire Pump Applications

ENGINE PERFORMANCE:

STANDARD CONDITIONS: (SAE J1349, ISO 3046)
 77°F (25°C) AIR INLET TEMPERATURE
 29.61 IN. (751.1MM) HG BAROMETRIC PRESSURE
 #2 DIESEL FUEL (SEE C13940)

Ken Wauligman

Ken Wauligman 27OCT06

ENGINE SPEED - RPM

● — ● NAMEPLATE kW (MAXIMUM PUMP LOAD)

THIS DRAWING AND THE INFORMATION
 HEREIN ARE OUR PROPERTY AND MAY
 BE USED BY OTHERS ONLY AS
 AUTHORIZED BY US. UNPUBLISHED --
 ALL RIGHTS RESERVED UNDER THE
 COPYRIGHT LAWS.

CREATED

KRW

DATE CREATED

05/19/04

ENGINE MODEL JU4H-UF14

DRAWING NO.

C131943

REV

B



JU4H-UF14 INSTALLATION & OPERATION DATA (I&O) UK Produced

Basic Engine Description

Engine Manufacturer	John Deere Co.
Ignition Type	Compression (Diesel)
Number of Cylinders	4
Bore and Stroke - mm (in)	106 (4.19) X 127 (5)
Displacement - L (in ³)	4.5 (275)
Compression Ratio	17.6:1
Valves per cylinder	
Intake	1
Exhaust	1
Combustion System	Direct Injection
Engine Type	In-Line, 4 Stroke Cycle
Fuel Management Control	Mechanical, Rotary Pump
Firing Order (CW Rotation)	1-3-4-2
Aspiration	Natural
Charge Air Cooling Type	None
Rotation, viewed from front of engine, Clockwise (CW)	Standard
Engine Crankcase Vent System	Open
Installation Drawing	D545
Weight - kg (lb)	413 (910)



Power Rating

	2350	2600	2800	3000
Nameplate Power - kW (HP) ¹	41 (55)	44 (59)	52 (70)	53 (71)

Cooling System - [C051001]

	2350	2600	2800	3000
Engine Coolant Heat - kW (Btu/sec)	31.7 (30)	33.8 (32)	35.9 (34)	38 (36)
Engine Radiated Heat - kW (Btu/sec)	7.4 (7)	7.8 (7.4)	8.8 (8.3)	8.9 (8.4)
Heat Exchanger Minimum Flow				
15°C (60°F) Raw H ₂ O - L/min (gal/min)	30.3 (8)	34.1 (9)	37.9 (10)	41.6 (11)
37°C (100°F) Raw H ₂ O - L/min (gal/min)	37.9 (10)	41.6 (11)	45.4 (12)	49.2 (13)
Heat Exchanger Maximum Cooling Raw Water				
Inlet Pressure - bar (psi)	14 (203)			
Flow - L/min (gal/min)	98.4 (26)			
Typical Engine H ₂ O Operating Temp - °C (°F)	76.7 (170) - 87.8 (190)			
Thermostat				
Start to Open - °C (°F)	76.7 (170)			
Fully Opened - °C (°F)	87.8 (190)			
Engine Coolant Capacity - L (qt)	12.5 (13.2)			
Coolant Pressure Cap - kPa (lb/in ²)	68.9 (10)			
Maximum Engine Coolant Temperature - °C (°F)	93.3 (200)			
Minimum Engine Coolant Temperature - °C (°F)	71.1 (160)			
High Coolant Temp Alarm Switch - °C (°F)	96.1 (205)			

Electric System - DC

	Standard		Optional	
System Voltage (Nominal)	12		24	
Battery Capacity for Ambients Above 32°F (0°C)				
Voltage (Nominal)	12	{C07633}	12	{C07633}
Qty. Per Battery Bank	1		2	
SAE size per J537	8D		8D	
CCA @ 18°C (0°F) per J537	1400		1400	
Reserve Capacity - Minutes per J537	430		430	
Battery Cable Circuit, Max Resistance - ohm	0.0012		0.0012	
Battery Cable Minimum Size				
0-3.1m Circuit Length ²	00		00	
3.1m-4.1m Circuit Length ²	000		000	
4.1m-5.1m Circuit Length ²	0000		0000	
Charging Alternator Maximum Output - Amp,	40	{C071363}	55	{C071366}
Starter Cranking Amps, Rolling - @15°C (60°F)	225	{C07888/C07889}	250	{C07819/C07820}

* All footnotes are at the bottom of Page 2

JU4H-UF14 INSTALLATION & OPERATION DATA (I&O) UK Produced



Exhaust System (Single Exhaust Outlet)	2350	2600	2800	3000
Exhaust Flow - m ³ /min (ft. ³ /min)	13.3 (469)	15 (531)	16.5 (581)	17.8 (630)
Exhaust Temperature - °C (°F)	584 (1083)	568 (1055)	556 (1033)	543 (1010)
Maximum Allowable Back Pressure - kPa (in H ₂ O)	7.5 (30)	7.5 (30)	7.5 (30)	7.5 (30)
Minimum Exhaust Pipe Dia. - mm (in) ³	76.2 (3)	76.2 (3)	76.2 (3)	76.2 (3)
Fuel System	2350	2600	2800	3000
Fuel Consumption - L/hr (gal/hr)	11.7 (3.1)	12.9 (3.4)	13.6 (3.6)	14.8 (3.9)
Fuel Return - L/hr (gal/hr)	34.1 (9)	36 (9.5)	37.5 (9.9)	39 (10.3)
Fuel Supply - L/hr (gal/hr)	45.8 (12.1)	48.8 (12.9)	51.1 (13.5)	53.7 (14.2)
Fuel Pressure - kPa (lb/in ²)	20.7 (3) - 41.4 (6)			
Minimum Line Size - Supply - in.50 Schedule 40 Steel Pipe			
Pipe Outer Diameter - mm (in)	21.5 (0.848)			
Minimum Line Size - Return - in.375 Schedule 40 Steel Pipe			
Pipe Outer Diameter - mm (in)	17.1 (0.675)			
Maximum Allowable Fuel Pump Suction Lift				
with clean Filter - mH ₂ O (in H ₂ O)	0.8 (31)			
Maximum Allowable Fuel Head above Fuel pump, Supply or Return - m (ft)	1.4 (4.5)			
Fuel Filter Micron Size	2			
Heater System	Standard		Optional	
Engine Coolant Heater				
Wattage (Nominal)	1000		1000	
Voltage - AC, 1 Phase	230 (+5%, -10%)		115 (+5%, -10%)	
Part Number	{C122192}		{C122188}	
Air System	2350	2600	2800	3000
Combustion Air Flow - m ³ /min (ft. ³ /min)	4.7 (166)	5.3 (186)	5.7 (202)	6.2 (218)
Air Cleaner	Standard		Optional	
Part Number	{C03249}		{C03327}	
Type	Indoor Service Only, with Shield		Canister, Single-Stage	
Cleaning method	Washable		Disposable	
Air Intake Restriction Maximum Limit				
Dirty Air Cleaner - kPa (in H ₂ O)	2.5 (10)		2.5 (10)	
Clean Air Cleaner - kPa (in H ₂ O)	1.2 (5)		1.2 (5)	
Maximum Allowable Temperature (Air To Engine Inlet) - °C (°F)	54.4 (130)			
Lubrication System				
Oil Pressure - normal - kPa (lb/in ²)	345 (50) - 655 (95)			
Low Oil Pressure Alarm Switch - kPa (lb/in ²)	138 (20)			
In Pan Oil Temperature - °C (°F)	104 (220) - 118 (245)			
Total Oil Capacity with Filter - L (qt)	15.1 (16)			
Lube Oil Heater	Optional		Optional	
Wattage (Nominal)	150		150	
Voltage	240V (+5%, -10%)		120V (+5%, -10%)	
Part Number	{C04431}		{C04430}	
Performance	2350	2600	2800	3000
BMEP - kPa (lb/in ²)	462 (67)	448 (65)	496 (72)	469 (68)
Piston Speed - m/min (ft/min)	597 (1958)	661 (2167)	711 (2333)	762 (2500)
Mechanical Noise - dB(A) @ 1m	C131536			
Power Curve	C131943			

NOTE: This engine is intended for indoor installation or in a weatherproof enclosure. ¹ Derate 3% per every 1000 ft. 304.8m above 300 ft. 91.4m and derate 1% for every 10°F 5.55 °C above 77°F 25°C. ² Positive and Negative Cables Combined Length. ³ Minimum Exhaust Pipe Diameter is based on: 15 feet of pipe, one 90° elbow, and one Industrial silencer. A Back-pressure flow analysis must be performed on the actual field installed exhaust system to assure engine maximum allowable back pressure is not exceeded. See Exhaust Sizing Calculator on www.clarkefire.com. { } indicates component reference part number.

CLARKE®

JU4H, JU4R & JU6H, JU6R ENGINE MODELS ENGINE MATERIALS AND CONSTRUCTION

Air Cleaner

Type..... Indoor Usage Only
Oiled Fabric Pleats
Material..... Surgical Cotton
Aluminum Mesh

Air Cleaner - Optional

Type..... Canister
Material..... Pleated Paper
Housing..... Enclosed

Camshaft

Material..... Cast Iron
Chill Hardened
Location..... In Block
Drive..... Gear, Spur
Type of Cam..... Ground

Charge Air Cooler (JU6H-60,62,68,74,84, 94, T8, T0, T2, ADK0, AD58, ADNG, ADN0, ADQ0, ADR0, AAQ8, AARG, ADP8, ADP0, ADT0, AD88, ADR8, AD98, ADS0, ADW8, ADX8, AD98 only)

Type..... Raw Water Cooled
Materials (in contact with raw water)
Tubes..... 90/10 CU/NI
Headers 36500 Muntz
Covers 83600 Red Brass
Plumbing 316 Stainless Steel/ Brass
90/10 Silicone

Charge Air Cooler (JU6R-AA67, 59, 61, PF, Q7, RF, S9, 83 only)

Type..... Air to Air Cooled
Materials
Core..... Aluminum

Coolant Pump

Type..... Centrifugal
Drive..... Poly Vee Belt

Coolant Thermostat

Type..... Non Blocking
Qty..... 1

Cooling Loop (Galvanized)

Tees, Elbows, Pipe..... Galvanized Steel
Ball Valves..... Brass ASTM B 124,
Solenoid Valve..... Brass
Pressure Regulator..... Bronze
Strainer..... Cast Iron (1/2" - 1" loops) or
Bronze (1.25" - 2" loops)

Cooling Loop (Sea Water)

Tees, Elbows, Pipe..... 316 Stainless Steel
Ball Valves..... 316 Stainless Steel
Solenoid Valve..... 316 Stainless Steel
Pressure Regulator/Strainer Cast Brass ASTM B176
C87800

Cooling Loop (316SS)

Tees, Elbows, Pipe..... 316 Stainless Steel
Ball Valves..... 316 Stainless Steel
Solenoid Valve..... 316 Stainless Steel
Pressure Regulator/Strainer 316 Stainless Steel

Connecting Rod

Type..... I-Beam Taper
Material..... Forged Steel Alloy

Crank Pin Bearings

Type..... Precision Half Shell
Number..... 1 Pair Per Cylinder
Material..... Wear-Guard

Crankshaft

Material..... Forged Steel
Type of Balance..... Dynamic

Cylinder Block

Type..... One Piece with
Non-Siamese Cylinders
Material..... Annealed Gray Iron

Cylinder Head

Type..... Slab 2 Valve
Material..... Annealed Gray Iron

Cylinder Liners

Type..... Centrifugal Cast, Wet Liner
Material..... Alloy Iron Plateau, Honed

Fuel Pump

Type..... Diaphragm
Drive..... Cam Lobe

Heat Exchanger (USA) - JU4H & JU6H Only

Type..... Tube & Shell
Materials
Tube & Headers..... Copper
Shell..... Copper
Electrode..... Zinc

Heat Exchanger (UK) - JU4H & JU6H Only

Type..... Tube & Bundle

Materials

Tube & Headers..... Copper
Shell..... Aluminum

Injection Pump

Type..... Rotary
Drive..... Gear

Lubrication Cooler

Type..... Plate

Lubrication Pump

Type..... Gear
Drive..... Gear

Main Bearings

Type..... Precision Half Shells
Material..... Steel Backed-Aluminum
Lined

Piston

Type and Material..... Aluminum Alloy with
Reinforced Top Ring Groove
Cooling..... Oil Jet Spray

Piston Pin

Type..... Full Floating - Offset

Piston Rings

Number/Piston..... 3
Top..... Keystone Barrel Faced -
Plasma Coated
Second..... Tapered Cast Iron
Third..... Double Rail Type
w/Expander Spring

Radiator - JU4R & JU6R Only

Type..... Plate Fin

Materials

Core..... Copper & Brass
Tank & Structure..... Steel

Optional

Marine Coating..... Baked Phenolic

Valves

Type..... Poppet
Arrangement..... Overhead Valve
Number/Cylinder..... 1 intake
1 exhaust
Operating Mechanism..... Mechanical Rocker Arm
Type of Lifter..... Large Head
Valve Seat Insert..... Replaceable

JU4H-UF14

Stationary Fire Pump Engine Driver

EMISSION DATA

EPA 40 CFR Part 60

4 Cylinders
 Four Cycle
 Lean Burn
 Naturally Aspirated

500 PPM SULFUR #2 DIESEL FUEL								
RPM	BHP ⁽³⁾	FUEL GAL/HR (L/HR)	GRAMS / HP- HR				EXHAUST	
			NMHC	NOx	CO	PM ⁽⁴⁾	°F (°C)	CFM (m ³ /min)
2800	70	3.6 (13.6)	0.77	3.79	2.38	0.16	1033 (556)	581 (16)
3000	71	3.9 (14.8)	0.83	3.64	2.80	0.18	1010 (543)	630 (18)

Notes:

- 1) 4045DF159 Base Engine Model manufactured by John Deere Corporation.
For John Deere Emissions Conformance to EPA 40 CFR Part 60 see Page 2 of 2.
- 2) The Emission Warranty for this engine is provided directly to the owner by John Deere Corporation. A copy of the John Deere Emission Warranty can be found in the Clarke Operation and Maintenance Manual.
- 3) Engines are rated at standard conditions of 29.61in. (7521 mm) Hg barometer and 77°F (25° C) inlet air temperature. (SAE J1349)
- 4) PM is a measure of total particulate matter, including PM₁₀.

CLARKE

FIRE PROTECTION PRODUCTS
 3133 EAST KEMPER ROAD
 CINCINNATI, OH 45241



John Deere Power Systems
 3801 W. Ridgeway Ave., PO Box 5100
 Waterloo, Iowa USA 50704-5100

31 October 2007

Subject: Fire Pump Ratings – Conformance to EPA 40 CFR Part 60 (NSPS requirements)

All John Deere stationary fire pump engines conform to the requirements of 40 CFR Part 60. All such engines include an emission label, stating the engine conforms to the requirements of 40 CFR Part 60. An example of the emission label is show below:

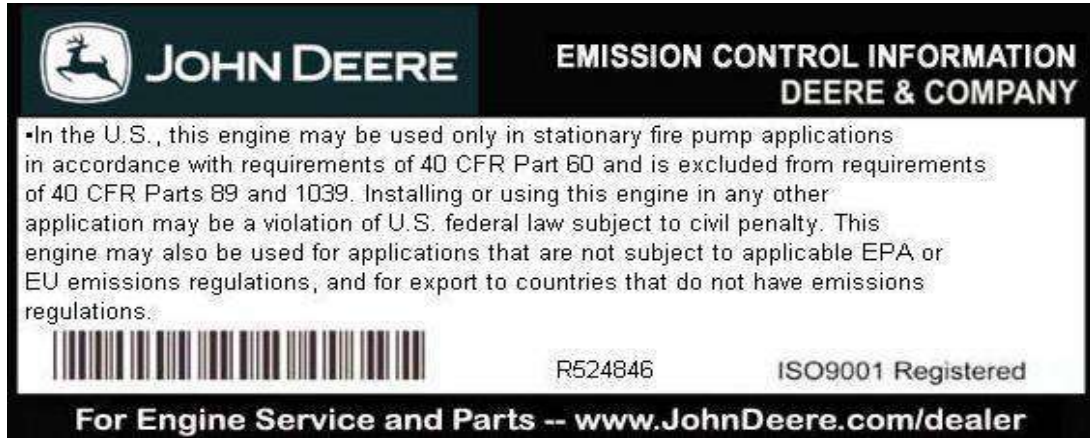

This label applies to all of the following engine models, sold to Clarke Fire Protection, for use in stationary fire pump applications:

John Deere Engine Model
4045DF120
4045DF159
4045TF252
4045TF254
4045TF220
6068TF252
6068TF254
6068HF252
6068HF254
6068HF120
6068TF220
6081AF001
6081HF001
6125AF001
6125HF070

All engines conforming to 40 CFR Part 60 (identified by emission label, as shown above) are covered under the emissions warranty of 40 CFR Part 89.

Sincerely,

Kyle J. Tingle
 Regional Sales Manager, JDPS

DATUMS:

- A- - MOUNTING FACE OF FLYWHEEL
- B- - ENGINE CRANKSHAFT HORIZONTAL
- C- - ENGINE CRANKSHAFT VERTICAL
- ☉ - CENTER OF GRAVITY
- ↻ - CLOCKWISE (CW) ROTATION WHEN VIEWED FROM FRONT OF ENGINE

CAUTION:

ALL PLUMBING MUST BE SUPPORTED AND/OR ISOLATED SO THAT NO WEIGHT OR STRESS IS APPLIED TO ANY ENGINE COMPONENT

ATTENTION:

REFER TO THE SPECIFIC MODELS' "INSTALLATION AND OPERATION DATA" FOR INSTALLATION GUIDELINES

AVAILABLE MODELS:

JU4H-UF34, -UFHO, -UFH2, -UF40
JU4H-UF42, -UF50, *-UF52, -UF54

*SEE PG3 FOR JU4H-UF52 RAW WATER CONNECTIONS

NOTES:

- 1) FUEL SUPPLY PIPING FROM TANK TO ENGINE SHOULD BE 1/2" MINIMUM PIPE DIAMETER
- 2) FUEL RETURN PIPING FROM TANK TO ENGINE SHOULD BE 3/8" MINIMUM PIPE DIAMETER
- 3) COOLING LOOP SHOWN IS BASED ON STANDARD CONSTRUCTION AND FM SIZING CONDITIONS

FOR ALTERNATE LOOP CONSTRUCTION (STAINLESS STEEL, SEA WATER AND HIGH PRESSURE) SIZES MAY VARY

DRAWING SUBJECT TO CHANGE WITHOUT NOTICE DO NOT SCALE

CONTROLLED DRAWING

THIS IS A REGISTERED PART WITH A THIRD PARTY AGENCY FOR USE ON A PRODUCT. NO SUBSTITUTIONS ARE ALLOWED. CONSULT ENGINEERING PRIOR TO AND REGARDING ANY CHANGE.

FOR ENGINE SPECIFIC OPTIONS SEE www.clarkefire.com

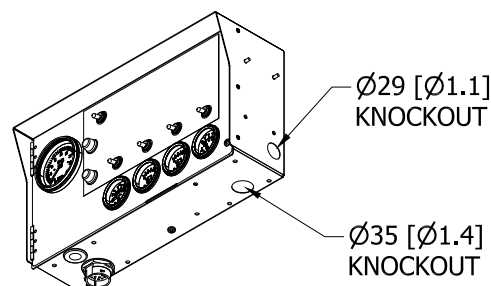

"T" MODELS	JU4H-UF34, -UFH0, JU4H-UFH2, -UF40, -UF42, JU4H-UF50, *-UF52, -UF54 SHOWN
"NA" MODELS	JU4H-UF04, -UF10, -UF12, -UF14, -UF20, -UF22, -UF24 IN PHANTOM

*FOR JU4H-UF52 RAW WATER INLET DIMENSIONS SEE PG. 3

CONDUIT KNOCKOUT LOCATIONS FOR CONTROLLER WIRING

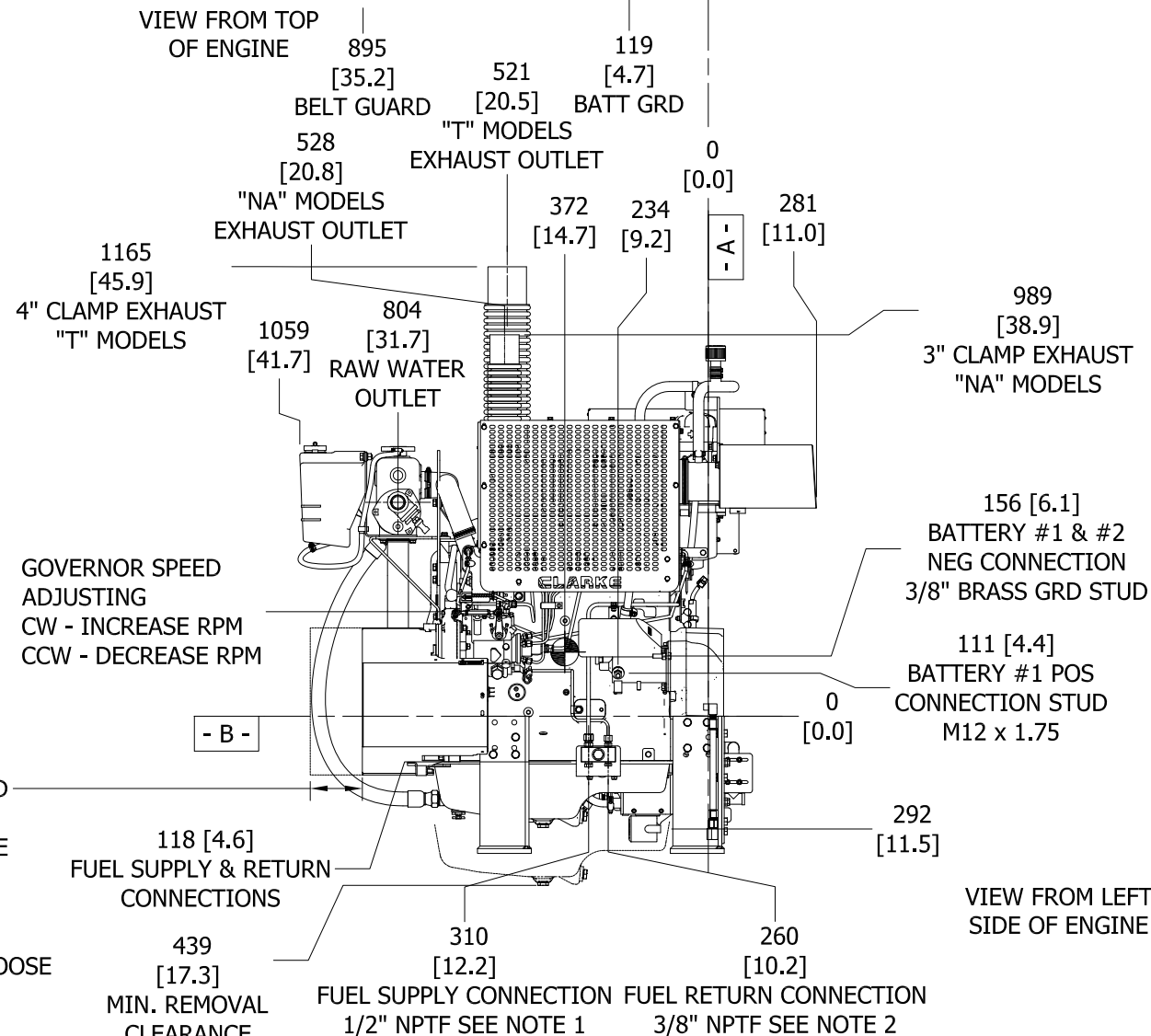
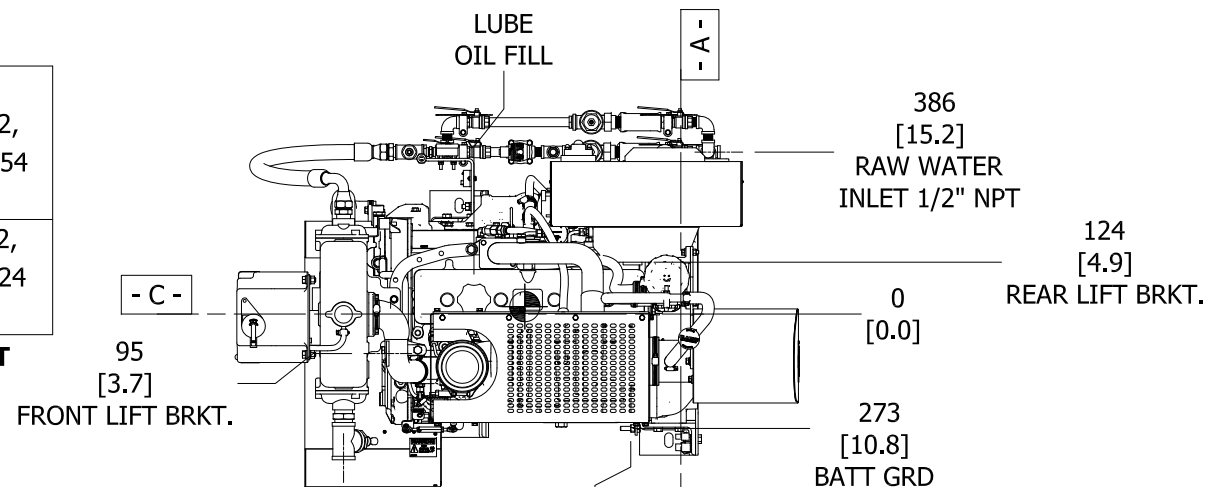
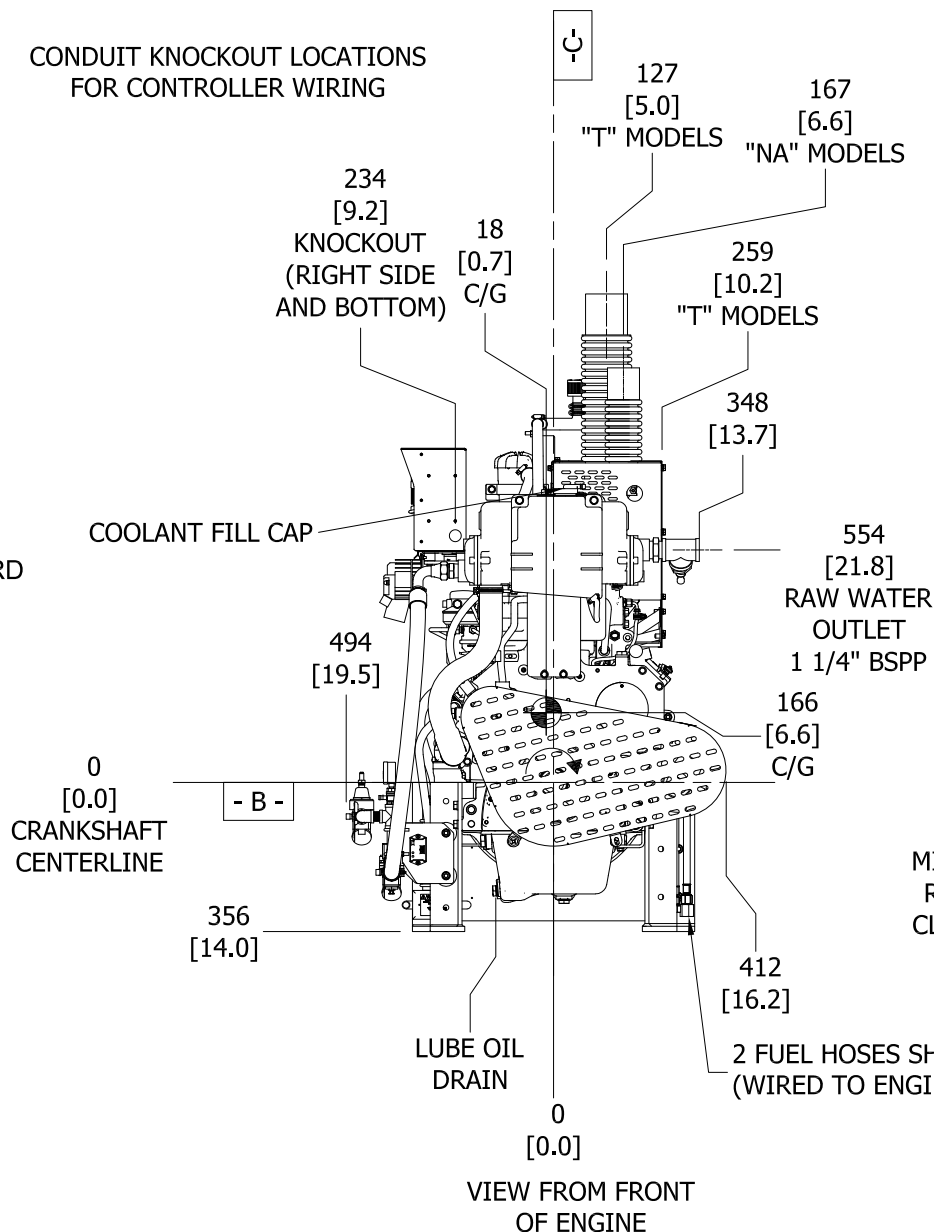

REV	DESCRIPTION	ECN#	DWN	APVD	DATE
V	UPDATED TOLERANCE, LOGO & DIMENSION PRECISION	5393	NMM	<i>[Signature]</i>	09MAY18
W	UPDATED ENGINE VIEWS	5983	LJV	NMM	03DEC19

<small>THIS DRAWING AND THE INFORMATION HEREON ARE OUR PROPERTY AND MAY BE USED BY OTHERS ONLY AS AUTHORIZED BY US. UNPUBLISHED-ALL RIGHTS RESERVED UNDER THE COPYRIGHT LAWS.</small>		<input checked="" type="checkbox"/> YES <input type="checkbox"/> NO CONTROLLED DRAWING		
<small>UNLESS NOTED OTHERWISE, TOLERANCING GUIDELINES WILL BE AS SHOWN BELOW</small>		DRWN: MLAUER DATE: 30AUG04		NAME: INSTALLATION DRAWING, FIRE PUMP ENGINE- JU4H-UF MODELS
<small>SUBMITTAL TOLERANCE</small>		ENGR: KJKUNKLER		PART NO.: D545
<small>ALL DIMENSIONS CAN VARY ± 0.03 [0.375]</small>		MATERIAL:		SCALE: NTS UNITS: MM [INCH]
		ASSEMBLY: SIMILAR TO: D534		REV: W PAGE 1 OF 3

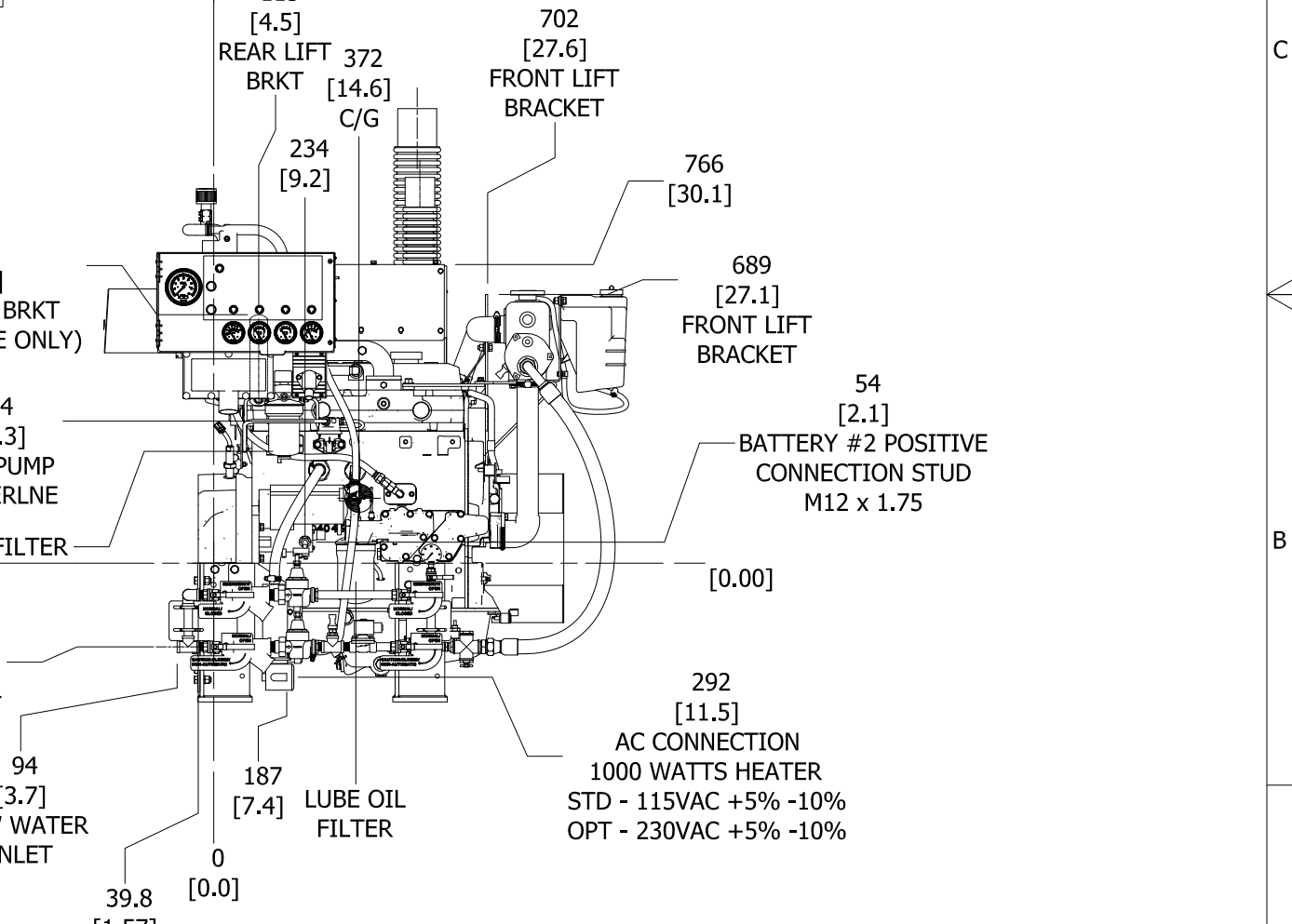
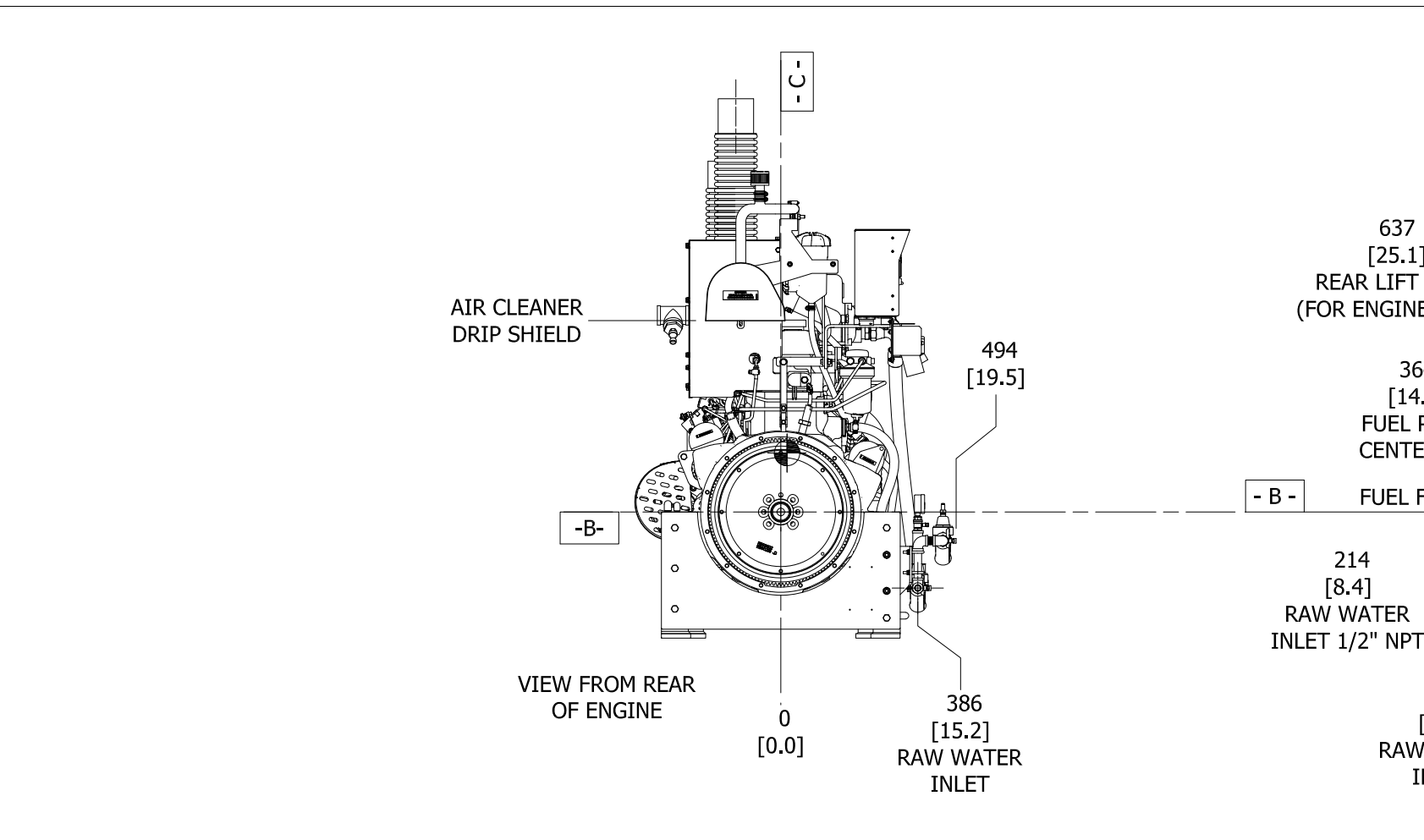
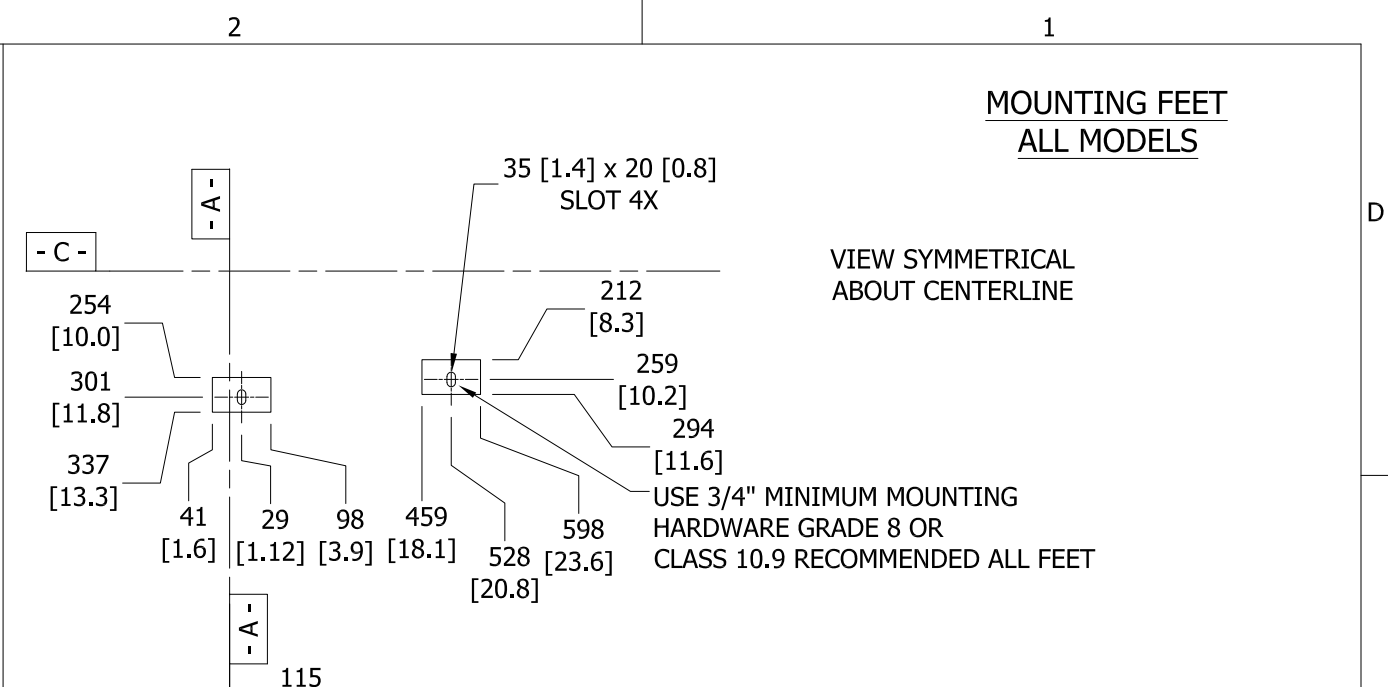
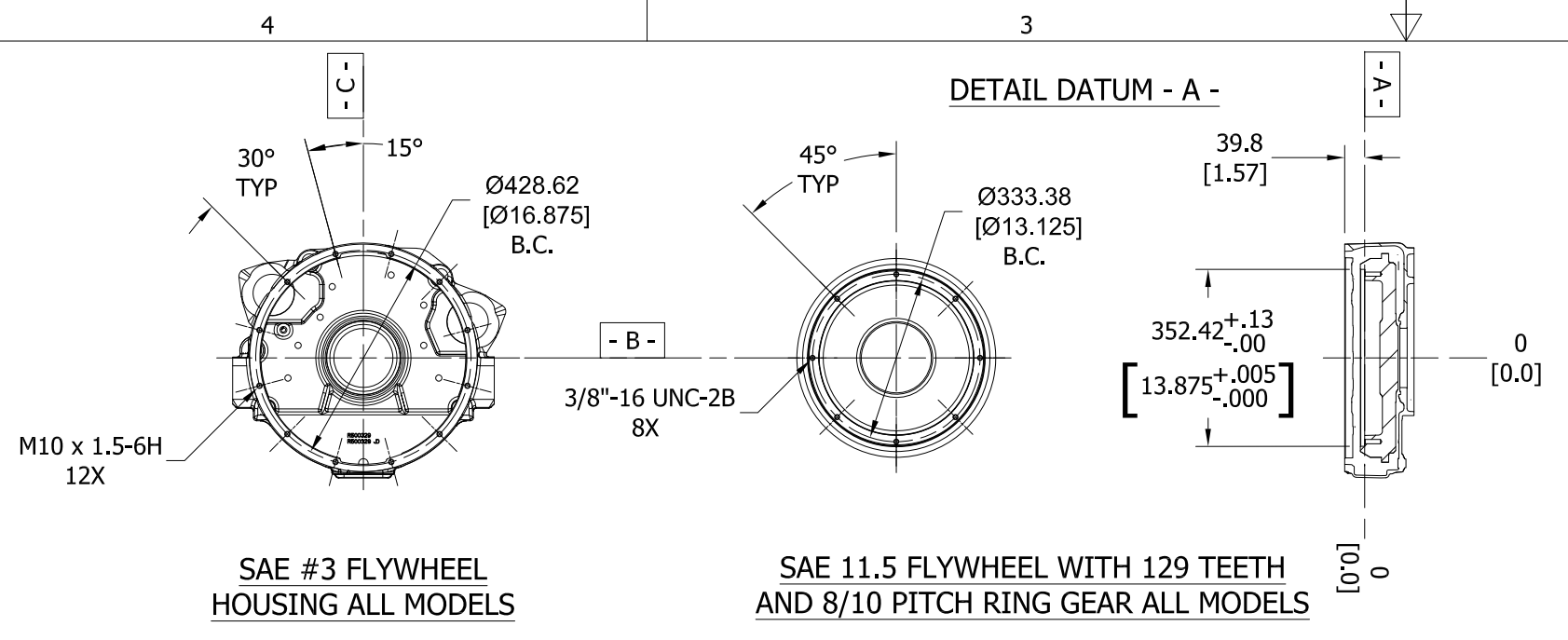

DRAWING SUBJECT TO CHANGE WITHOUT NOTICE DO NOT SCALE

FOR ENGINE SPECIFIC OPTIONS SEE www.clarkefire.com

THIS DRAWING AND THE INFORMATION HEREON ARE OUR PROPERTY AND MAY BE USED BY OTHERS ONLY AS AUTHORIZED BY US. UNPUBLISHED--ALL RIGHTS RESERVED UNDER THE COPYRIGHT LAWS.

UNLESS NOTED OTHERWISE, TOLERANCING GUIDELINES WILL BE AS SHOWN BELOW.

SUBMITTAL TOLERANCE

ALL DIMENSIONS CAN VARY ± 9.53 [0.375]

YES	NO
<input checked="" type="checkbox"/>	<input type="checkbox"/>
CONTROLLED DRAWING	
DRWN	MLAUER
DATE	30AUG04
ENGR	KJKUNKLER
MATERIAL	
ASSEMBLY	
SIMILAR TO	D534

		INSTALLATION DRAWING, FIRE PUMP ENGINE-JU4H-UF MODELS	
		PART NO. D545	REV W
SCALE	UNITS		PAGE 2 OF 3
NTS	MM [INCH]		

4

3

2

1

VIEW FROM REAR OF ENGINE

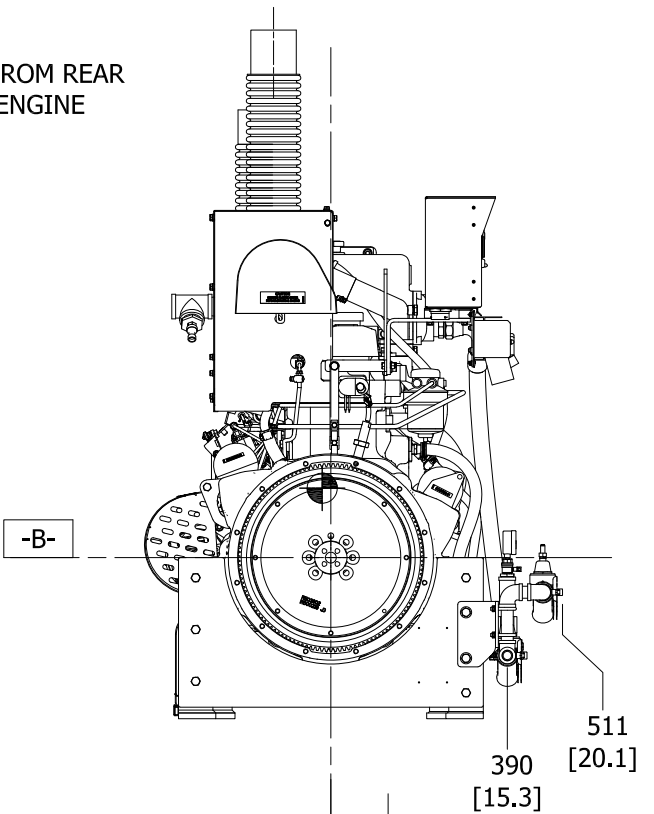

VIEW FROM TOP OF ENGINE

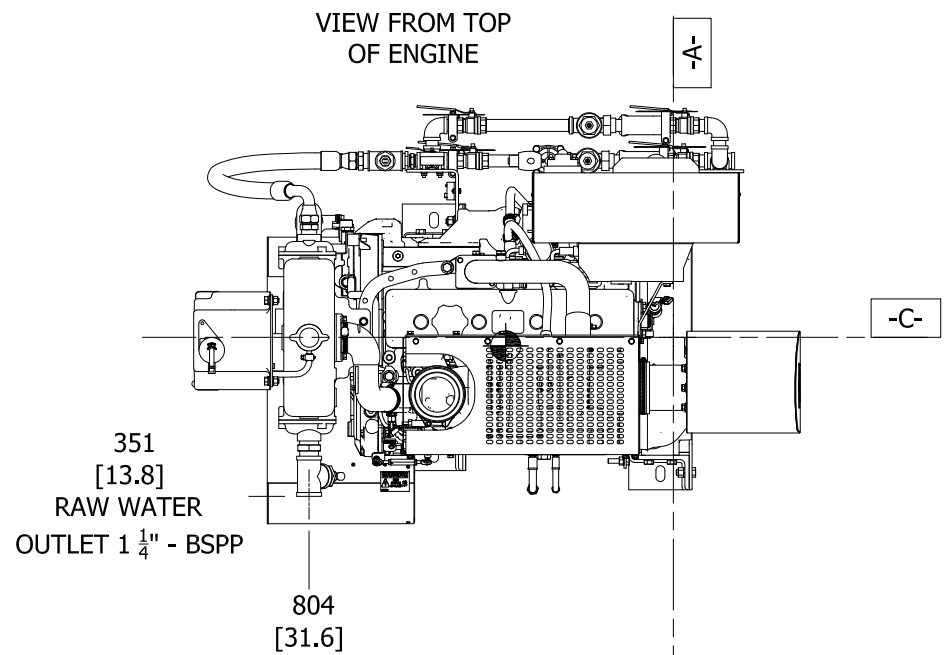

"T" (TURBOCHARGED) MODELS	JU4H-UF52
---------------------------------	-----------

DRAWING SUBJECT TO CHANGE WITHOUT NOTICE DO NOT SCALE

FOR ALL OTHER MODELS SEE PAGE 2

DATUMS:

- A- - MOUNTING FACE OF FLYWHEEL
- B- - ENGINE CRANKSHAFT HORIZONTAL ϕ
- C- - ENGINE CRANKSHAFT VERTICAL ϕ
- CENTER OF GRAVITY
- CLOCKWISE (CW) ROTATION WHEN VIEWED FROM FRONT OF ENGINE

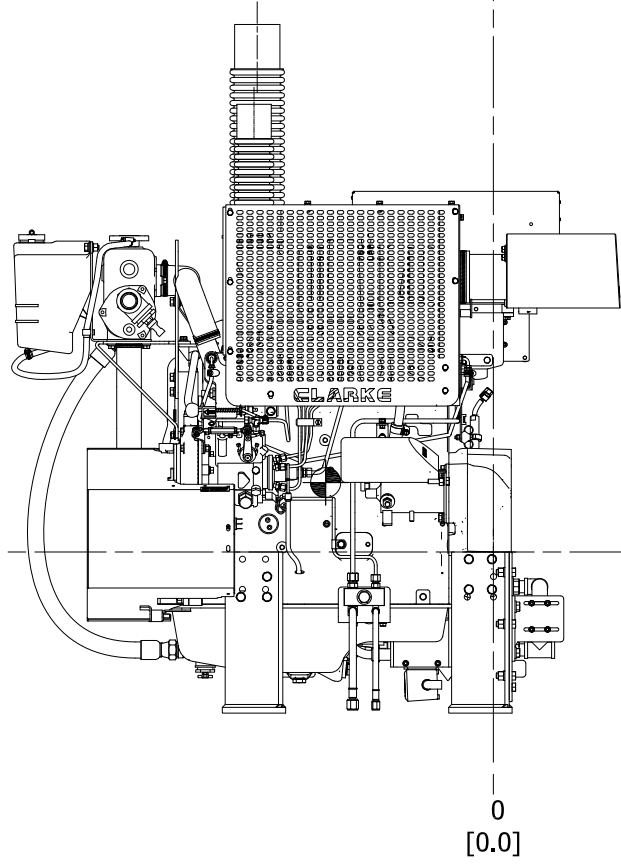
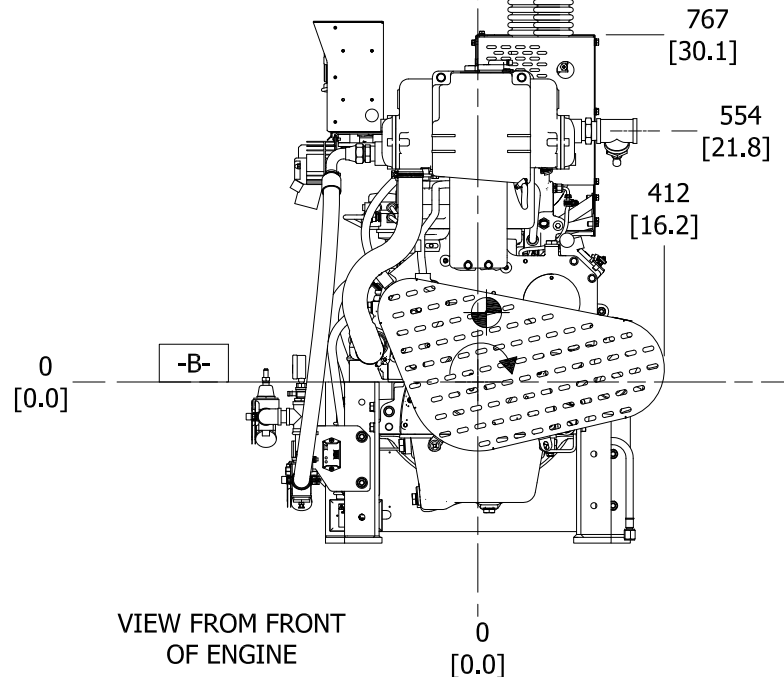

VIEW FROM RIGHT SIDE OF ENGINE

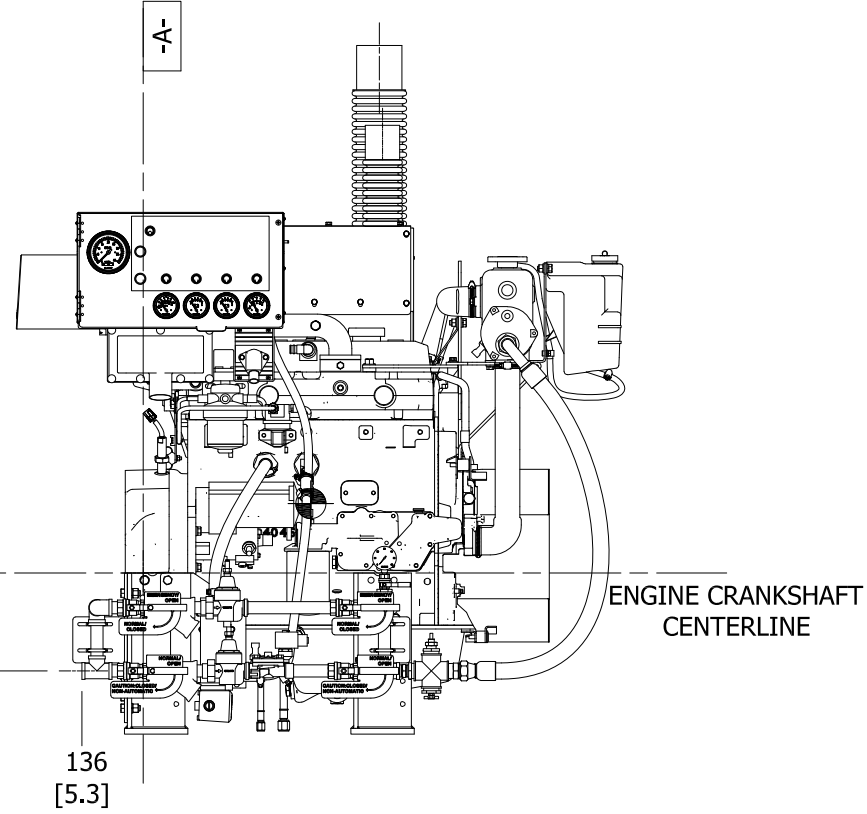

VIEW FROM FRONT OF ENGINE

JU4H-UF52 RAW WATER INLET & OUTLET LOCATIONS OTHERWISE SAME AS ALL OTHER MODELS

THIS DRAWING AND THE INFORMATION HEREON ARE OUR PROPERTY AND MAY BE USED BY OTHERS ONLY AS AUTHORIZED BY US. UNPUBLISHED--ALL RIGHTS RESERVED UNDER THE COPYRIGHT LAWS

UNLESS NOTED OTHERWISE, TOLERANCING GUIDELINES WILL BE AS SHOWN BELOW

SUBMITTAL TOLERANCE

ALL DIMENSIONS CAN VARY ± 0.005 [0.127]

YES	NO
<input checked="" type="checkbox"/>	<input type="checkbox"/>
CONTROLLED DRAWING	
DRWN	MLAUER
DATE	30AUG04
ENGR	KJKUNKLER
MATERIAL	
ASSEMBLY	
SIMILAR TO	D534

CLARKE		NAME	
		INSTALLATION DRAWING, FIRE PUMP ENGINE- JU4H-UF MODELS	
		PART NO.	D545
		SCALE	NTS
		UNITS	MM [INCH]
		PAGE	3 OF 3
		REV	W

4

3

2

1



JU4H-UF14

FIRE PUMP DRIVER

NOISE DATA

Mechanical Engine Noise *

RPM	BHP	OVERALL dB(A)	Octave Band									
			31.5 Hz dB(A)	63 Hz dB(A)	125 Hz dB(A)	250 Hz dB(A)	500 Hz dB(A)	1k Hz dB(A)	2k Hz dB(A)	4k Hz dB(A)	8k Hz dB(A)	16k Hz dB(A)
2800	70	101.60	64.00	69.70	86.40	85.80	92.40	97.20	95.50	92.30	84.30	73.10
3000	71	102.60	63.90	70.50	85.20	86.60	94.80	98.20	97.00	96.00	87.50	73.80

Raw Exhaust Engine Noise **

RPM	BHP	OVERALL dB(A)	Octave Band									
			31.5 Hz dB(A)	63 Hz dB(A)	125 Hz dB(A)	250 Hz dB(A)	500 Hz dB(A)	1k Hz dB(A)	2k Hz dB(A)	4k Hz dB(A)	8k Hz dB(A)	16k Hz dB(A)
2800-3000	70-71	104.00		93.80	98.20	92.90	95.10	94.70	97.40	93.60	84.30	77.90

* Values above are provided at 3.3ft (1m) from engine block and do not include the raw exhaust noise.

** Values above are provided at 23ft (7m), 90° horizontal, from a vertical exhaust outlet and does not include noise created mechanically by the engine.

The above data reflects nominal values for a typical engine of this model, speed and power in a free-field environment, tested at a no-load condition.

Installation specifics such as background noise level and amplification of noise levels from reflecting off of surrounding objects, will affect the overall noise levels observed. As a result of this, Clarke makes no guarantees to the above levels in an actual installation.

DIESEL FIRE PUMP CONTROLLER DATA

Fire Fighting Solutions Provider

ص.ب: ٧٤٥٨٢ . دبي الامارات العربية المتحدة تيلفون : ٣٤٧٧٠٧٣ / ٣٤٧٢٤٢٦ ء ٩٧١ ء ٣٤٧٢٣٦٣ فاكس : ٩٧١ ء ٣٤٧٢٣٦٣

P.O.Box: 74582 Dubai, UAE. Tel : +971 4 3472426 / 3477073 Fax : +971 4 3472363 E -mail: sales@bristol-fire.com, www.bristol-fire.com



TORNATECH

Project: _____

Customer: _____

Engineer: _____

Pump Manufacturer: _____

Technical Data Submittal Document

Model GPD

Diesel Engine Driven Fire Pump Controller



Contents:

Data Sheets
Dimensional Data
Wiring Schematics
Field Connections

Note: The drawings included in this package are for controllers covered under our standard offering. Actual AS BUILT drawings may differ from what is shown in this package.



N.Y.C.
APPROVED



February 2019



Standard, Listings, Approvals and Certifications	Built to NFPA 20 (latest edition)	
	Underwriters Laboratory (UL)	<ul style="list-style-type: none"> • UL218 - Fire Pump Controllers • CSA C22.2 No. 14 Industrial Control Equipment
	FM Global	Class 1321/1323
	New York City	Accepted for use in the City of New York by the Department of Buildings
	Seismic Certification	See page 5 for details
	Optional	
<input type="checkbox"/> CE Mark	Various EN, IEC & CEE directives and standards	
Enclosure	Protection Rating	
	<input type="checkbox"/> Standard: NEMA 2 (IP31)	
	Optional	
	<input type="checkbox"/> NEMA 12 <input type="checkbox"/> NEMA 3 <input type="checkbox"/> NEMA 3R <input type="checkbox"/> NEMA 4	<input type="checkbox"/> NEMA 4X-304 sst painted <input type="checkbox"/> NEMA 4X-304 sst brushed finish <input type="checkbox"/> NEMA 4X-316 sst painted <input type="checkbox"/> NEMA 4X-316 sst brushed finish
Accessories		Paint Specifications
<ul style="list-style-type: none"> • Bottom entry gland plate • Lifting Lugs • Keylock handle 		<ul style="list-style-type: none"> • Red RAL3002 • Powder coating • Glossy textured finish
Ambient Temperature Rating	Standard	
	<input type="checkbox"/> 4°C to 40°C / 39°F to 104°F Optional <input type="checkbox"/> 4°C to 55°C / 39°F to 131°F Controllers built in Dubai, UAE (Tornatech FZE) are supplied standard with 55°C rating.	
General	AC	<input type="checkbox"/> 120V / 1ph / 60hz <input type="checkbox"/> 208V to 240V / 1ph / 50-60hz
	DC	<input type="checkbox"/> 12VDC <input type="checkbox"/> 24VDC
	Grounding system	• Negative
	Battery chargers	<ul style="list-style-type: none"> • Two independent fully automatic • 10A continuous charge • 500mA trickle charge
Electrical Reading	<ul style="list-style-type: none"> • Battery 1 & Battery 2 voltage • Battery 1 & Battery 2 charging amperage • Charging mode 	
Pressure Reading	<ul style="list-style-type: none"> • Continuous system pressure display • Cut-in and cut-out pressure setting 	
Pressure and Event Recorder	<ul style="list-style-type: none"> • Pressure readings with date stamp • Event recording with date stamp • Under regular maintained operation, events are stored in memory for the life of the controller. • Data viewable on operator interface display screen • Downloadable by USB port to external memory device 	





Pressure sensing	<ul style="list-style-type: none"> • Pressure transducer and run test solenoid valve assembly for fresh water application • Pressure sensing connection 1/2" Female NPT • Drain connection 3/8" • Rated and calibrated for 0-500psi working pressure • Externally mounted with protective cover
Audible Alarm	4" alarm bell - 85 dB at 10ft. (3m)
Visual Indications	<ul style="list-style-type: none"> • Engine run • Main switch AUTO • Main switch in OFF • Main switch in HAND • Periodic test • Cranking Cycle • AC Power available • Pump room temperature (°F or °C)
Visual & Audible Alarms	<p>Visual only</p> <ul style="list-style-type: none"> • Pump room trouble • Pump on demand • AC Failure • Charger 1 Failure • Charger 2 Failure • Weak battery 1 • Weak battery 2 • Battery 1 overvoltage • Battery 2 overvoltage <p>Visual and Audible</p> <ul style="list-style-type: none"> • Engine trouble • Controller trouble • Engine low oil pressure • Engine high temperature • Engine low temperature • Engine overspeed • DC Failure • Loss of continuity 1 • Loss of continuity 2 • High fuel level • Fuel tank leak • PLD low suction pressure • High raw water temperature • Low pump room temperature • Battery 1 Failure • Battery 2 Failure • Engine fail to start • Low fuel level • ECM fault • ECM SS in Alternate Position • Fuel injection malfunction • High pump room temperature • ECM warning • Weekly test cut-in not reached • Check weekly test solenoid • Pressure transducer fault • Invalid Cut-In • Service required
Remote Alarm Contacts	<p>DPDT-8A-250V.AC</p> <ul style="list-style-type: none"> • Engine run • Common controller trouble <ul style="list-style-type: none"> • Charger #1 & Charger #2 failure • Pressure transducer fault • Common engine trouble <ul style="list-style-type: none"> • High engine temperature • Fail to start • Fuel injection malfunction** • ECM selector switch in alternate position*** • Common pump room trouble (field re-assignable)* <ul style="list-style-type: none"> • Low fuel level • High fuel level • Fuel tank leak • H-O-A selector switch in OFF or HAND • Free (field programmable)* • Battery #1 & battery #2 failure • DC failure • Loss of continuity (starter) #1 and/or #2 • PLD low suction pressure • Overspeed • Fail when running • Low oil pressure • Low pump room temperature • High pump room temperature • AC Failure

*Except if option C13 is ordered. Tornatech reserves the right to use any of these four alarm points for special specific application requirements

**Applicable to electronic engines only.

*** Applicable to electronic engines only. Alarms when ECM selector switch on the engine is in alternate mode.



Terminals for Field Connections for External Devices	<ul style="list-style-type: none"> • Low fuel level • Remote AUTOMATIC start • Deluge valve start (re-assignable) • Fuel tank leak (re-assignable) • High fuel level (re-assignable) 		
ViZiTouch V2 Operator Interface	<ul style="list-style-type: none"> • Embedded microcomputer with software PLC logic • 7.0" color touch screen (HMI technology) • Upgradable software • Multi-language 		
Operation	Selector Switch	<ul style="list-style-type: none"> • Hand-Off-Auto • Behind lockable and breakable cover 	
	Automatic Start	<ul style="list-style-type: none"> • Start on pressure drop • Remote start signal from automatic device 	
	Manual Start	<ul style="list-style-type: none"> • Crank 1 and Crank 2 start pushbuttons • Run test pushbutton • Deluge valve start • Remote start from manual device 	
	Crank Cycle	<ul style="list-style-type: none"> • 6 consecutive cycle attempts <ul style="list-style-type: none"> • 3 X 15s crank from battery 1 or 2 alternatively • 15s rest in between each crank attempt 	
	Stopping	<ul style="list-style-type: none"> • Manual with Stop pushbutton • Automatic after expiration of minimum run timer **** 	
	Timers	Field Adjustable & Visual Countdown	<ul style="list-style-type: none"> • Minimum run timer ****(off delay) • Sequential start timer (on delay) • Periodic test timer
	Actuation	Visual Indication	<ul style="list-style-type: none"> • Pressure • Non-pressure
	Mode		<ul style="list-style-type: none"> • Automatic • Non-automatic
Communication Protocol Capability	<ul style="list-style-type: none"> • Protocol: Modbus • Connection type: Shielded female connector RJ45 • Frame Format: TCP/IP • Addresses: See bulletin MOD-GPD 		

Alarm and shutdown schedule		Automatic Start	Manual or Remote Start	Run Test or Periodic Test
	High Coolant	Alarm only	Alarm only	Shutdown
	Low Oil Pressure	Alarm only	Alarm only	Shutdown
	Overspeed	Shutdown	Shutdown	Shutdown

	Wall Mount		Floor Mount	
Starting Voltage	Approx. shipping dimensions in inches (mm)	Approx. Shipping Weight in Lbs (kg)	Approx. shipping dimensions in inches (mm)	Approx. Shipping Weight in Lbs (kg)
12V.DC	32" l x 29" w x 16" h (813 x 737 x 407)	85 (39)	32" l x 29" w x 26" h (813 x 737 x 661)	115 (52)
24V.DC				

**** Automatic shutdown shall be approved by the AHJ.



Seismic Certification	Seismic Certification Company	TRU Compliance, LLC A Tobalski Watkins Affiliate					TWEI Project No.: 15014				
	Mounting details	Rigid wall mounting									
	Seismic Information	Building Code	Test Criteria	Seismic Parameters	S_{DS}	z/h	I_P	A_{FLX-H}	A_{RIG-H}	A_{FLX-V}	A_{RIG-V}
	IBC 2015, CBC 2016	ICC-ES AC156	ASCE 7-10 Chapter 13	2.0	1.0	1.5	3.20	2.40	1.33	0.53	
				3.2	0.0	1.5	3.20	1.28	2.13	0.85	

RRS for Nonstructural Components Testing

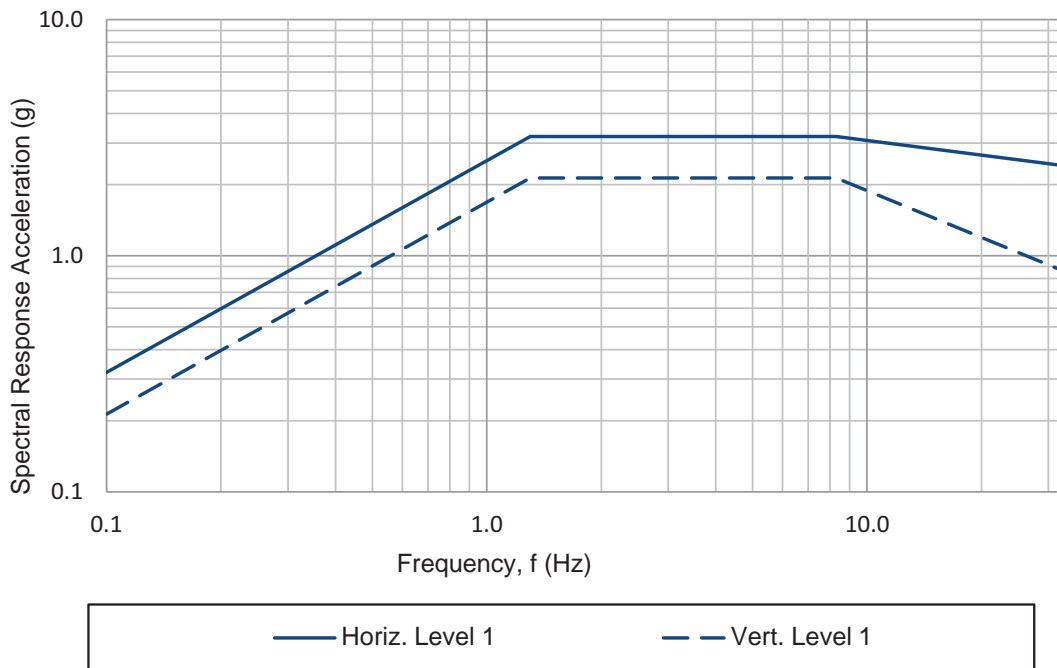

Notes:

- Components are tested in accordance with ICC-ES AC156, IBC 2015 & CBC 2016.
- OSHPD Special Seismic Certification Preapproval (OSP)



<input type="checkbox"/>	A1	Periodic test alarm contact (DPDT)
<input type="checkbox"/>	A2	Overspeed alarm contact (DPDT)
<input type="checkbox"/>	A3	Low oil pressure alarm contact (DPDT)
<input type="checkbox"/>	A4	High coolant temperature alarm contact (DPDT)
<input type="checkbox"/>	A5	Failure to start alarm contacts alarm contact (DPDT)
<input type="checkbox"/>	A6	Battery 1 & 2 failure alarm contact (2 x DPDT)
<input type="checkbox"/>	A7	Charger 1 & 2 failure alarm contact (2 x DPDT)
<input type="checkbox"/>	A8	AC failure alarm contact (DPDT)
<input type="checkbox"/>	A9	System overpressure alarm contact (For engines with PLD) (DPDT)
<input type="checkbox"/>	A11	Extra controller trouble alarm contact (DPDT)
<input type="checkbox"/>	A12	Extra engine trouble alarm contact (DPDT)
<input type="checkbox"/>	Ax	Additional engine alarm contact (DPDT) (specify function)
<input type="checkbox"/>	B1	Low fuel level alarm contact (DPDT)
<input type="checkbox"/>	B2	Water reservoir level low alarm contact (DPDT)
<input type="checkbox"/>	B3	Water reservoir empty alarm contact (DPDT)
<input type="checkbox"/>	B4	Low pump room temperature alarm contact (DPDT)
<input type="checkbox"/>	B5	High fuel level alarm contact (DPDT)
<input type="checkbox"/>	B6	Low system (discharge) pressure alarm contact (DPDT)
<input type="checkbox"/>	B7	Low suction pressure alarm contact (DPDT)
<input type="checkbox"/>	B8	Pump on demand alarm contact (DPDT)
<input type="checkbox"/>	B9	Fuel tank leak alarm contact (DPDT)
<input type="checkbox"/>	B10	Main relief valve open alarm contact (DPDT)
<input type="checkbox"/>	B11	Flow meter loop valve open alarm contact (DPDT)
<input type="checkbox"/>	B12	Water reservoir level high alarm contact (DPDT)
<input type="checkbox"/>	B13	High pump room temperature alarm contact (DPDT)
<input type="checkbox"/>	Bx	Additional pump room alarm contact (DPDT) (specify function)
<input type="checkbox"/>	C5	CE Mark with factory certificate
<input type="checkbox"/>	C6	Nickel – cadmium battery chargers (Battery data sheet required)
<input type="checkbox"/>	C7	Engine block heater circuit - 3KW max (same voltage as battery charger primary)

<input type="checkbox"/>	C7A	Engine block heater circuit - 6KW max (same voltage as battery charger primary) Confirm power rating of block heater
<input type="checkbox"/>	C9	Non pressure actuated controller w/o pressure transducer and run test solenoid valve
<input type="checkbox"/>	C13	Louver activation circuit (battery power specific)
<input type="checkbox"/>	C14	Delayed automatic start on AC power failure (factory set at 15 minutes)
<input type="checkbox"/>	C15	Low zone pump control function
<input type="checkbox"/>	C16	Middle zone pump control function
<input type="checkbox"/>	C17	High zone pump control function
<input type="checkbox"/>	C19	Lockout/interlock circuit from equipment installed inside the pump room
<input type="checkbox"/>	D4	Pressure transducer and run test solenoid valve for fresh water rated for 0-500psi (for factory calibration purposes only)
<input type="checkbox"/>	D6	Pressure transducer and run test solenoid valve for sea water rated for 0-500PSI
<input type="checkbox"/>	D7A	Low fuel level float switch supplied as separate item (1-1/4")
<input type="checkbox"/>	D7B	Low fuel level float switch supplied as separate item (1-1/2")
<input type="checkbox"/>	D8A	High fuel level float switch supplied as separate item (1-1/4")
<input type="checkbox"/>	D8B	High fuel level float switch supplied as separate item (1-1/2")
<input type="checkbox"/>	D9A	Anti-condensation heater & thermostat
<input type="checkbox"/>	D9B	Anti-condensation heater & humidistat
<input type="checkbox"/>	D9C	Anti-condensation heater & thermostat & humidistat
<input type="checkbox"/>	D11	Low suction pressure transducer for fresh water rated at 0-300PSI with visual indication and alarm contact
<input type="checkbox"/>	D11A	Low suction pressure transducer for sea water rated at 0-300PSI with visual indication and alarm contact
<input type="checkbox"/>	D12	Tropicalization
<input type="checkbox"/>	D25	Mounting stand
<input type="checkbox"/>	D25A	Mounting stand SST- 304 painted
<input type="checkbox"/>	D25B	Mounting stand SST- 304 brushed finish
<input type="checkbox"/>	D25C	Mounting stand SST- 316 painted
<input type="checkbox"/>	D25D	Mounting stand SST- 316 brushed finish
<input type="checkbox"/>	D26	Combined low and high fuel level float switch (1-1/4")

Note: Options chosen from this page are not electrically represented on the wiring schematics in this submittal package.



<input type="checkbox"/>	D26A	Combined low and high fuel level float switch (1-1/2")
<input type="checkbox"/>	D27	Fuel level probe (2") Level indication
<input type="checkbox"/>	D28A	Field programmable I/O board - 5 Input / 5 output
<input type="checkbox"/>	D30	Redundant pressure transducer for fresh water rated for 0-500PSI
<input type="checkbox"/>	D31	Redundant pressure transducer for sea water rated for 0-500PSI
<input type="checkbox"/>	D32	Modbus with RTU frame format and RS485 connection

<input type="checkbox"/>	L01	Other language and English (bilingual)
<input type="checkbox"/>	L02	French
<input type="checkbox"/>	L03	Spanish
<input type="checkbox"/>	L04	German
<input type="checkbox"/>	L05	Italian
<input type="checkbox"/>	L06	Polish
<input type="checkbox"/>	L07	Romanian
<input type="checkbox"/>	L08	Hungarian
<input type="checkbox"/>	L09	Slovak
<input type="checkbox"/>	L10	Croatian
<input type="checkbox"/>	L11	Czech
<input type="checkbox"/>	L12	Portuguese
<input type="checkbox"/>	L13	Dutch
<input type="checkbox"/>	L14	Russian
<input type="checkbox"/>	L15	Turkish
<input type="checkbox"/>	L16	Swedish
<input type="checkbox"/>	L17	Bulgarian
<input type="checkbox"/>	L18	Thai
<input type="checkbox"/>	L19	Indonesian
<input type="checkbox"/>	L20	Slovenian
<input type="checkbox"/>	L21	Danish
<input type="checkbox"/>	L22	Greek
<input type="checkbox"/>	L23	Arabic
<input type="checkbox"/>	L24	Hebrew
<input type="checkbox"/>	L25	Chinese

Additional Options:

Note: Options chosen from this page are not electrically represented on the wiring schematics in this submittal package.

ViZiTouch V2 Operator Interface

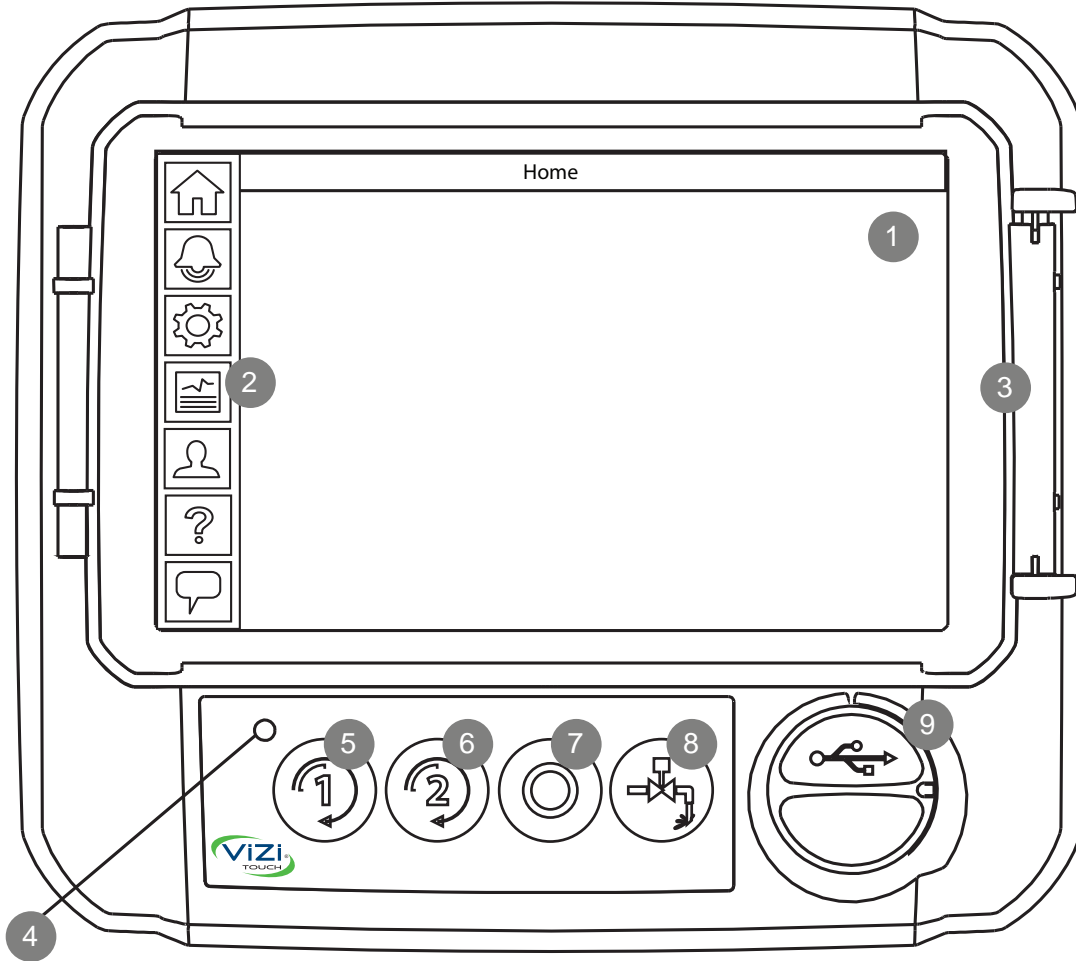

- | | |
|------------------------|--------------------------|
| 1 - Color touch screen | 3 - Screen protector |
| 2 - Onscreen menu | 4 - Power LED (3 colors) |
| • HOME page | 5 - CRANK 1 button |
| • ALARM page | 6 - CRANK 2 button |
| • CONFIGURATION page | 7 - STOP button |
| • HISTORY page | 8 - RUN TEST button |
| • SERVICE page | 9 - USB port |
| • MANUAL page | |
| • LANGUAGES page | |

Diesel Engine Fire Pump Controller

12Vdc or 24Vdc Negative Ground

Model: GPD

Dimensions

Built to the latest edition of the NFPA 20 standard

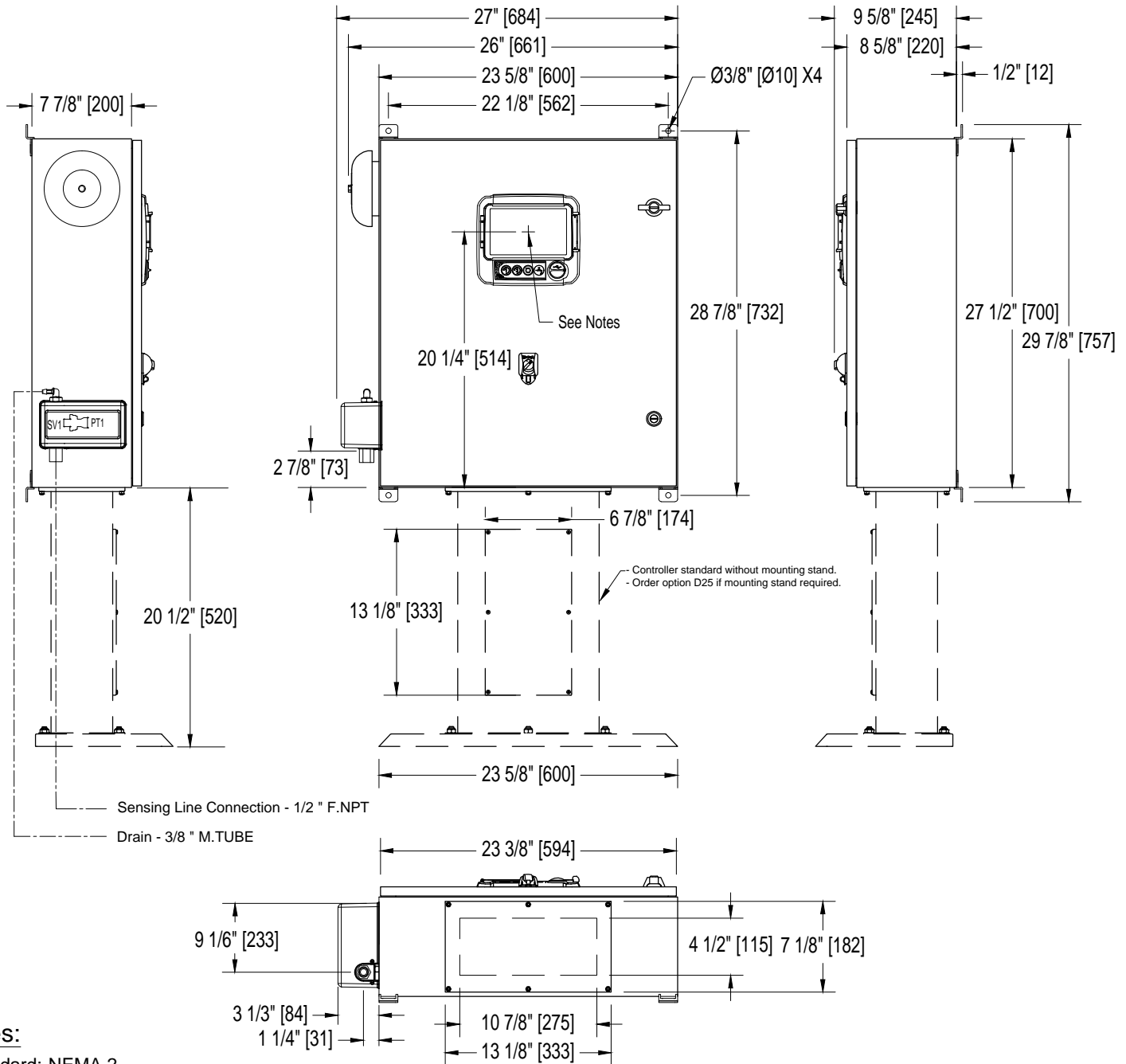

Notes:

- Standard: NEMA 2
- Standard paint : textured red RAL 3002.
- All dimensions are in inches [millimeters].
- Center of ViZiTouch screen: 20-1/4" [514] from bottom (no feet).
- Bottom conduit entrance through removable gland plate recommended.
- Use watertight conduit and connector only.
- Protect equipment against drilling chips.
- Door swing equal to door width.
- Seismic mounting to be rigid wall only.

Drawing for information only.
 Manufacturer reserves the right to modify this drawing without notice.
 Contact manufacturer for "As Built" drawing.

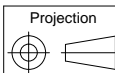

REV.	DESCRIPTION	DD/MM/YY	Drawing number
1.	Revised logo	18/06/18	GPD-DI700 /E
0.	First issue	18/11/16	

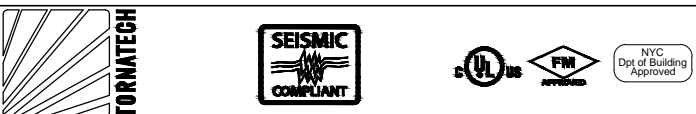

Diesel Engine Fire Pump Controller

12VDC or 24VDC Negative Ground

Model: GPD

Wiring schematic

Built to the latest edition of the NFPA 20 standard

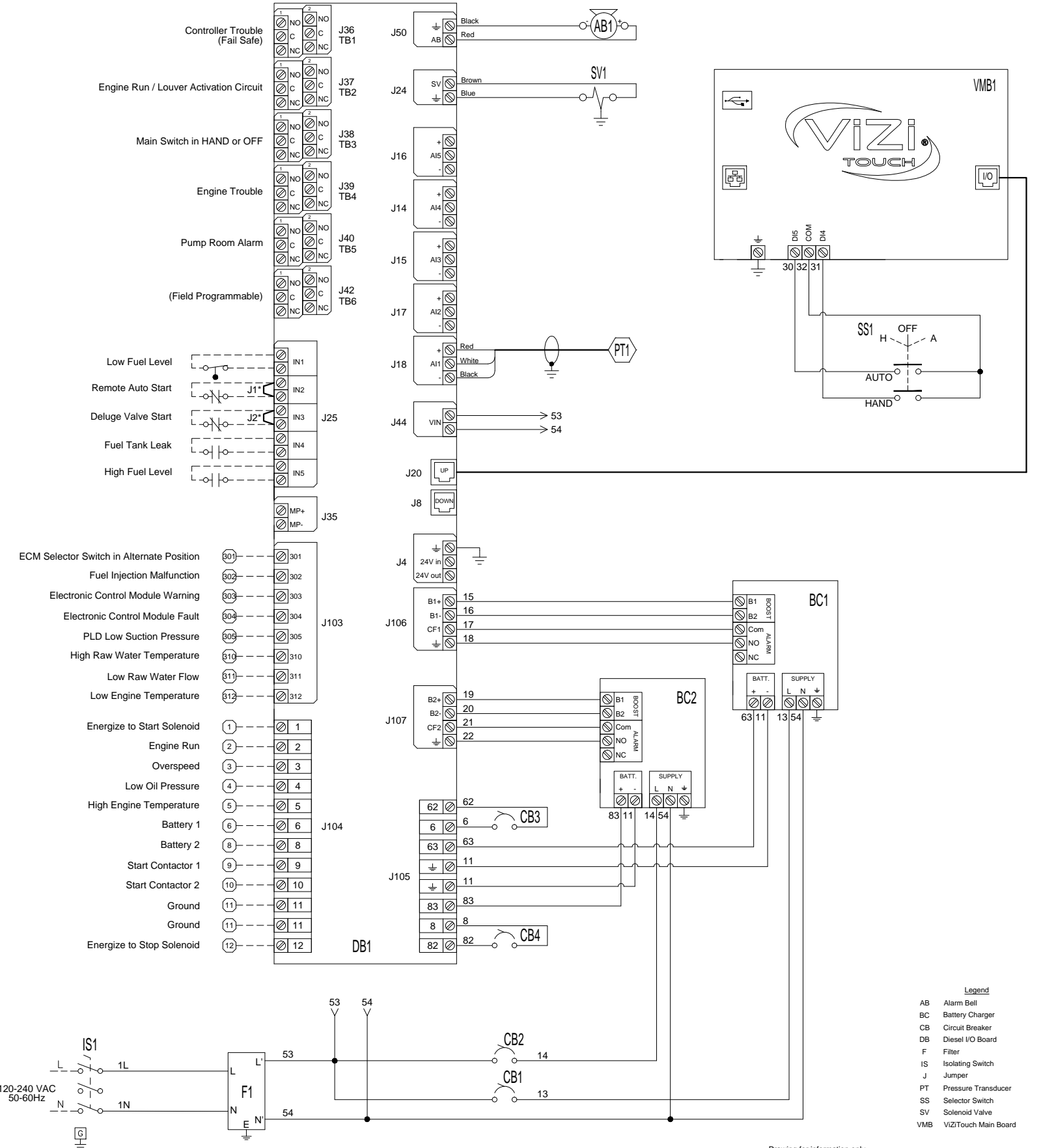

- Legend**
- AB Alarm Bell
 - BC Battery Charger
 - CB Circuit Breaker
 - DB Diesel I/O Board
 - F Filter
 - IS Isolating Switch
 - J Jumper
 - PT Pressure Transducer
 - SS Selector Switch
 - SV Solenoid Valve
 - VMB ViziTouch Main Board

Drawing for information only.
 Manufacturer reserves the right to modify this drawing without notice.
 Contact manufacturer for "As Built" drawing.

* Remove jumper to use this feature

REV.	DESCRIPTION	DD/MM/YY	Drawing number
2	Revised logo	18/06/18	GPD-WS700 /E
1	Corrected SS1 inputs	16/01/17	
0	First issue	10/11/16	

Diesel Engine Fire Pump Controller

12VDC or 24VDC Negative Ground

Layout

Model:GPD

Built to the latest edition of the NFPA 20 standard

Designation	Description
BC1-BC2	Battery Charger #1 and #2
CB1-2	Magnetic Breaker 1 Pole 10 A
CB3-4	Magnetic Breaker 1 Pole 16 A
DB1	I/O Diesel Board
F1	Filter
IS1	Isolating Switch
SS1	Lockable 3 Position Selector Switch
VMB1	ViZiTouch Main Board

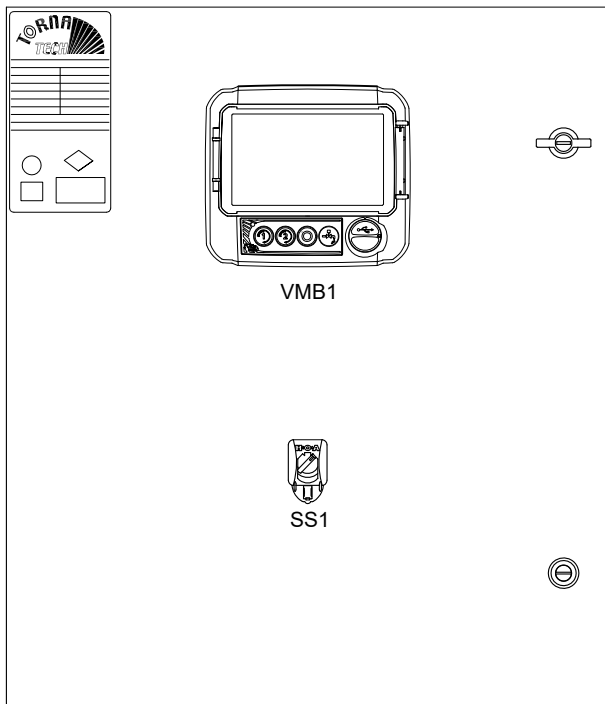

Front Door Layout

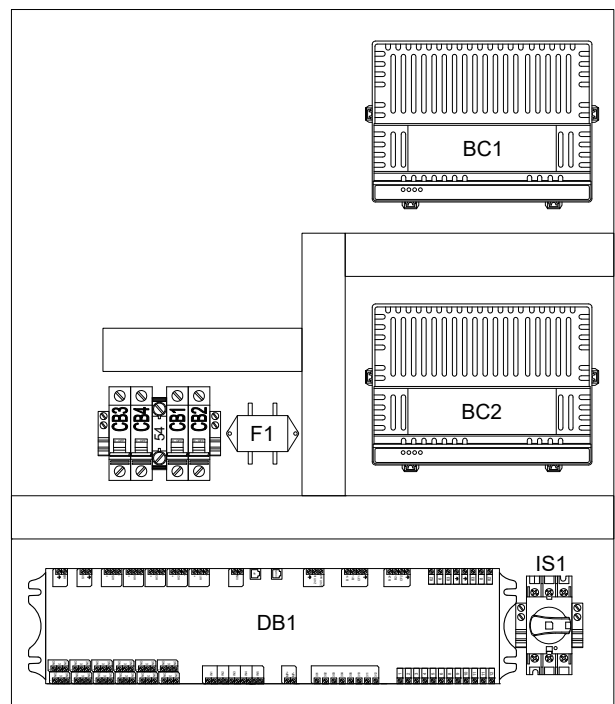

Internal Layout



REV.	DESCRIPTION	DD/MM/YY	Drawing number
1	Revised logo	18/06/18	GPD-LY700 /E
0	First issue	21/11/16	

Diesel Engine Fire Pump Controller

12VDC or 24VDC Negative Ground

Model: GPD

Terminal Diagram

Built to the latest edition of the NFPA 20 standard

Power Supply

Terminals Wire Size:
14 - 6 AWG
3.9 Nm

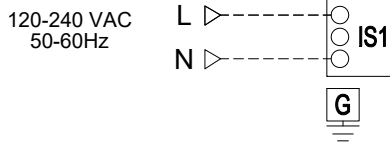

Engine Connections (DB1)

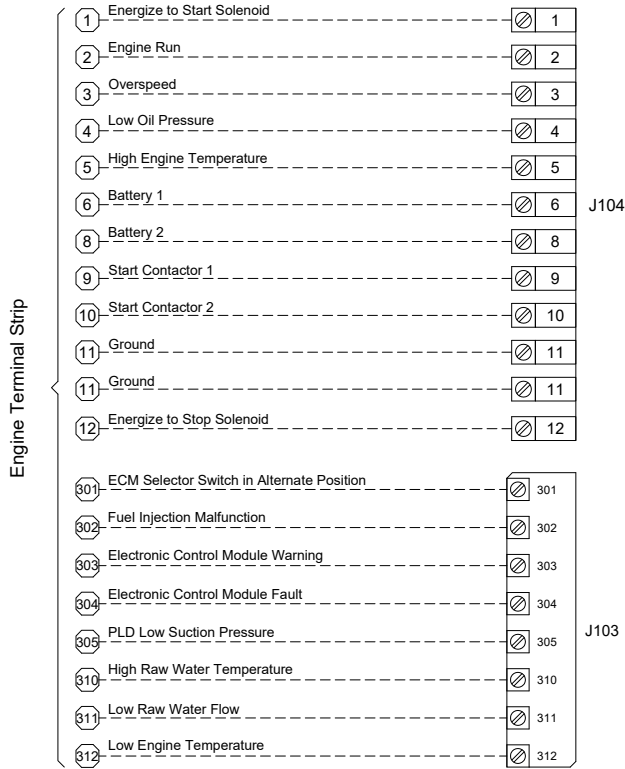

Field Connections (DB1)

Terminals Wire Size:
24 - 12 AWG
0.5 Nm

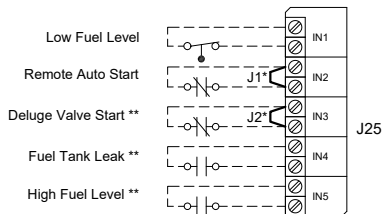

Network Connection (VMB1)

Shielded Female Connector RJ45

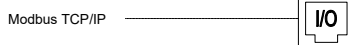

Remote Alarm Terminals (DB1)

Terminals Wire Size:
24 - 12 AWG
0.5 Nm

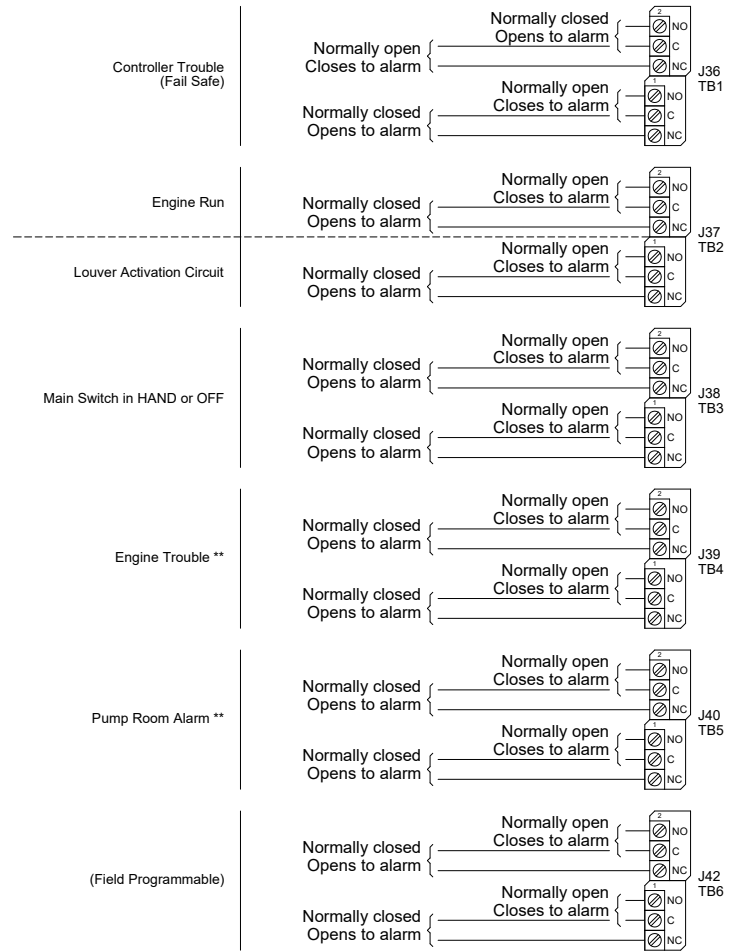

All wiring between the controller and diesel engine shall be stranded (NFPA20)

Wiring between controller and engine (terminals 301, 302, 303, 304, 305, 310, 311, 312, 2, 3, 4, 5) must be #14AWG as minimum.

Wiring between controller and engine (terminals 12 [rated at 10A or 22A for 20 seconds] 1, 9, 10 [rated at 10A]) must be stranded #10AWG as minimum.

Wiring between controller and engine (terminals 6, 8, 11 [rated at 30A]) must be stranded and sized according to distance.

Drawing for information only.
Manufacturer reserves the right to modify this drawing without notice.
Contact manufacturer for "As Built" drawing.

* Remove jumper to use this feature
** Re-assignable



REV.	DESCRIPTION	DD/MM/YY	Drawing number
1	Revised logo	18/06/18	GPD-TD700 /E
0	First issue	10/11/16	

Diesel Engine Fire Pump Controller

12VDC or 24VDC Negative Ground

Model: GPD

Louver Connection

Built to the latest edition of the NFPA 20 standard

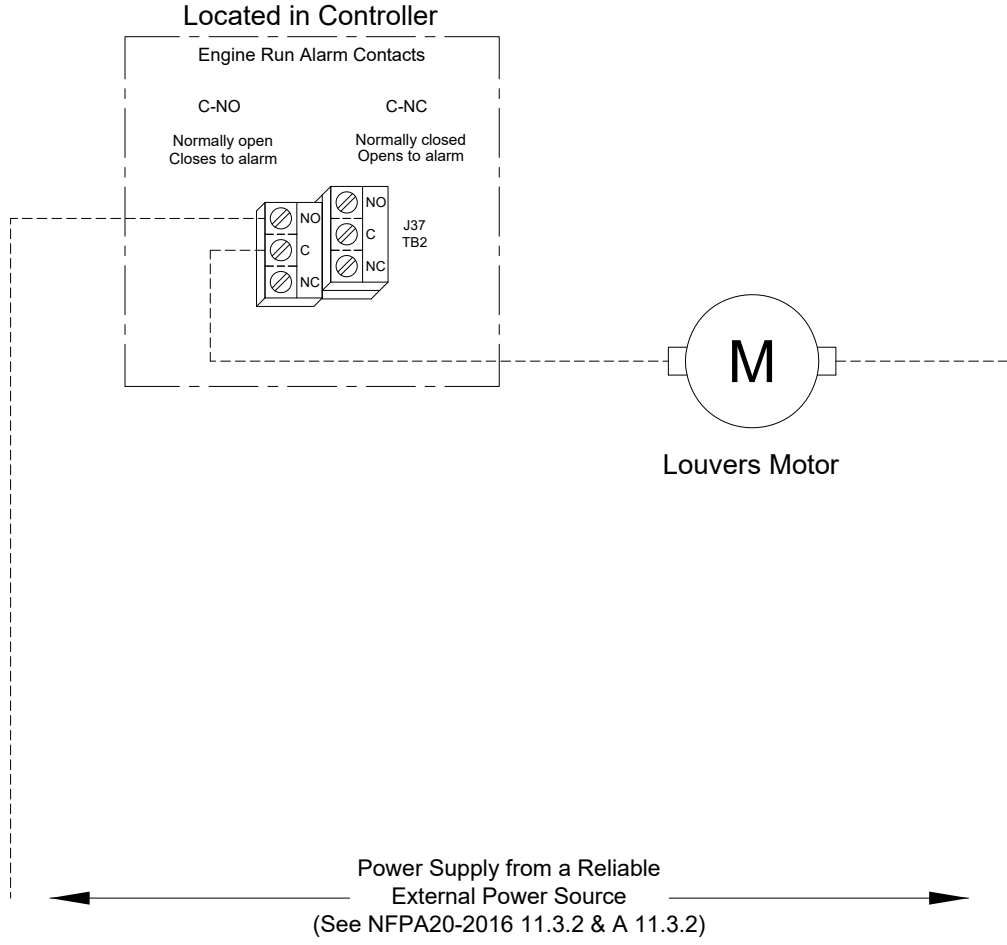

REV.	DESCRIPTION	DD/MM/YY	Drawing number
1	Revised logo	18/06/18	GPD-TD701 /E
0	First issue	10/11/16	

ELECTRIC FIRE PUMP DATA SHEET & CURVE

Fire Fighting Solutions Provider

ص.ب: ٧٤٥٨٢ , دبي الامارات العربية المتحدة تيلفون : ٣٤٧٧٠٧٣ / ٣٤٧٢٤٢٦ ء ٩٧١ ء ٣٤٧٢٣٦٣ فاكس : ٩٧١ ء ٣٤٧٢٣٦٣

P.O.Box: 74582 Dubai, UAE. Tel : +971 4 3472426 / 3477073 Fax : +971 4 3472363 E-mail: sales@bristol-fire.com, www.bristol-fire.com

BRISTOL



FIRE PUMPS

HORIZONTAL SPLIT CASE, END SUCTION, VERTICAL TURBINE,

CONTAINERIZED PUMP, PACKAGED FIRE PUMP, FUEL TANK & ANTI-VORTEX PLATE





END SUCTION TYPE



Description

Are designed according to NFPA 20 for firefighting applications. This pump is designed with latest technology and has premium components for easy maintenance and absolute efficiency .

Features

- Available in electric motor driven or engine driven configuration
- UL File No. : EX16459
- Dynamically balanced impellers

Performance Range

- Capacity : From 50 GPM up to 1000 GPM
- Head : From 50 MTR up to 209 MTR

Pump Dimensions

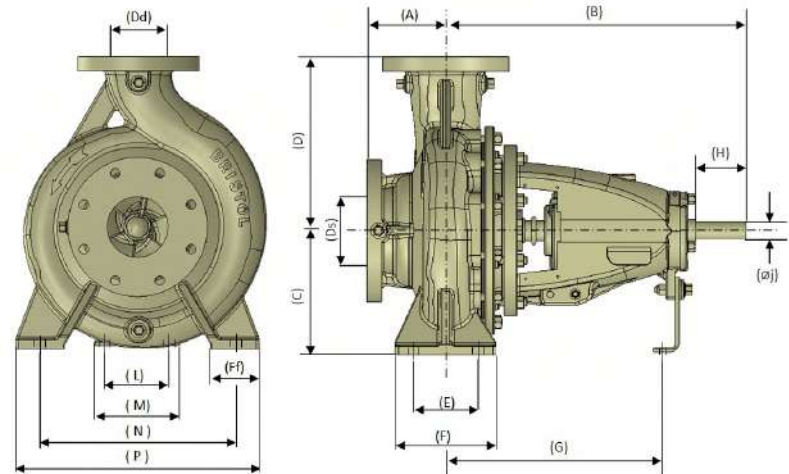

MODEL	A	B	C	D	E	F	Ff	G	H	L	M	N	P	Ø j	keyway
IS32 - 200	80	360	160	183.5	70	100	50	267	49	110	140	190	240	22.2	4.7X4.7X32
IS32 - 260	100	360	180	228	95	125	65	267	49	110	140	250	320	22.2	4.7X4.7X32
IS50 - 320H	125	470	225	285.6	95	125	65	342	79.4	110	140	280	345	28.5	6.35X6.35X44.5
IS65 - 320H	125	470	225	280	120	160	80	342	79.4	110	140	315	400	28.5	6.35X6.35X44.5
IS80 - 260	125	470	200	280	120	160	80	342	79.4	110	140	315	400	28.5	6.35X6.35X44.5
IS80 - 320H	125	470	250	317.4	120	160	80	342	79.4	110	140	315	400	28.5	6.35X6.35X44.5
IS100 - 260	140	470	225	280	120	160	80	342	79.4	110	140	315	400	28.5	6.35X6.35X44.5
IS100 - 320H	142	470	250	316	120	160	80	342	79.4	110	140	315	400	28.5	6.35X6.35X44.5
BEP 3X2.5LP	105	465	180	225	95	125	65	337	80	110	140	250	320	32	6X6X35
BEP 4X3LP	125	470	180	250	95	125	65	342	80	110	140	280	345	32	8X8X56



End Suction Pump Flange Details

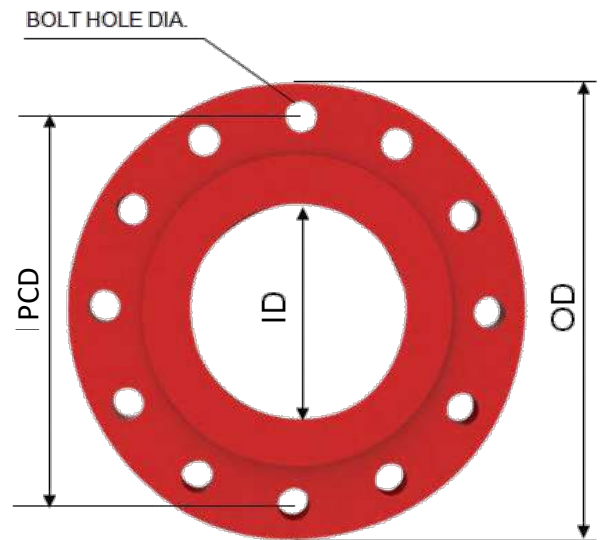

Model	Suction					Discharge				
	ID	(Pump Casing Range) OD	No. of Holes	Bolt Hole DIA	PCD	ID	(Pump Casing Range) OD	No. of Holes	Bolt Hole DIA	PCD
IS32-200	50	165	4	5/8"-11UNC-2B	120.7	32	140	4	1/2"-13UNC-2B	88.9
IS32-260	50	165	4	5/8"-11UNC-2B	120.7	32	140	4	1/2"-13UNC-2B	88.9
IS50-320H	65	185	4	5/8"-11UNC-2B	139.7	50	165	4	5/8"-11UNC-2B	120.7
IS65-320H	80	200	4	5/8"-11UNC-2B	152.4	65	185	4	5/8"-11UNC-2B	139.7
IS80-260	100	229	8	5/8"-11UNC-2B	190.5	80	200	4	5/8"-11UNC-2B	152.4
IS80-320H	100	229	8	5/8"-11UNC-2B	190.5	80	200	4	5/8"-11UNC-2B	152.4
IS100-260	125	254	8	3/4"-10UNC-2B	215.9	100	229	8	5/8"-11UNC-2B	190.5
IS100-320H	125	254	8	3/4"-10UNC-2B	215.9	100	229	8	5/8"-11UNC-2B	190.5
BEP 3X2.5LP	80	200	8	18	158.75	65	190.5	4	18	150
BEP 4X3LP	100	220	8	18	181	80	200	8	18	158.75

* Standard for Cast Iron Flanged Fittings : ANSI / ASME B16.1

* Standard for Ductile Iron Flanged Fittings : ANSI/ASME B16.42

End Suction Pump Components

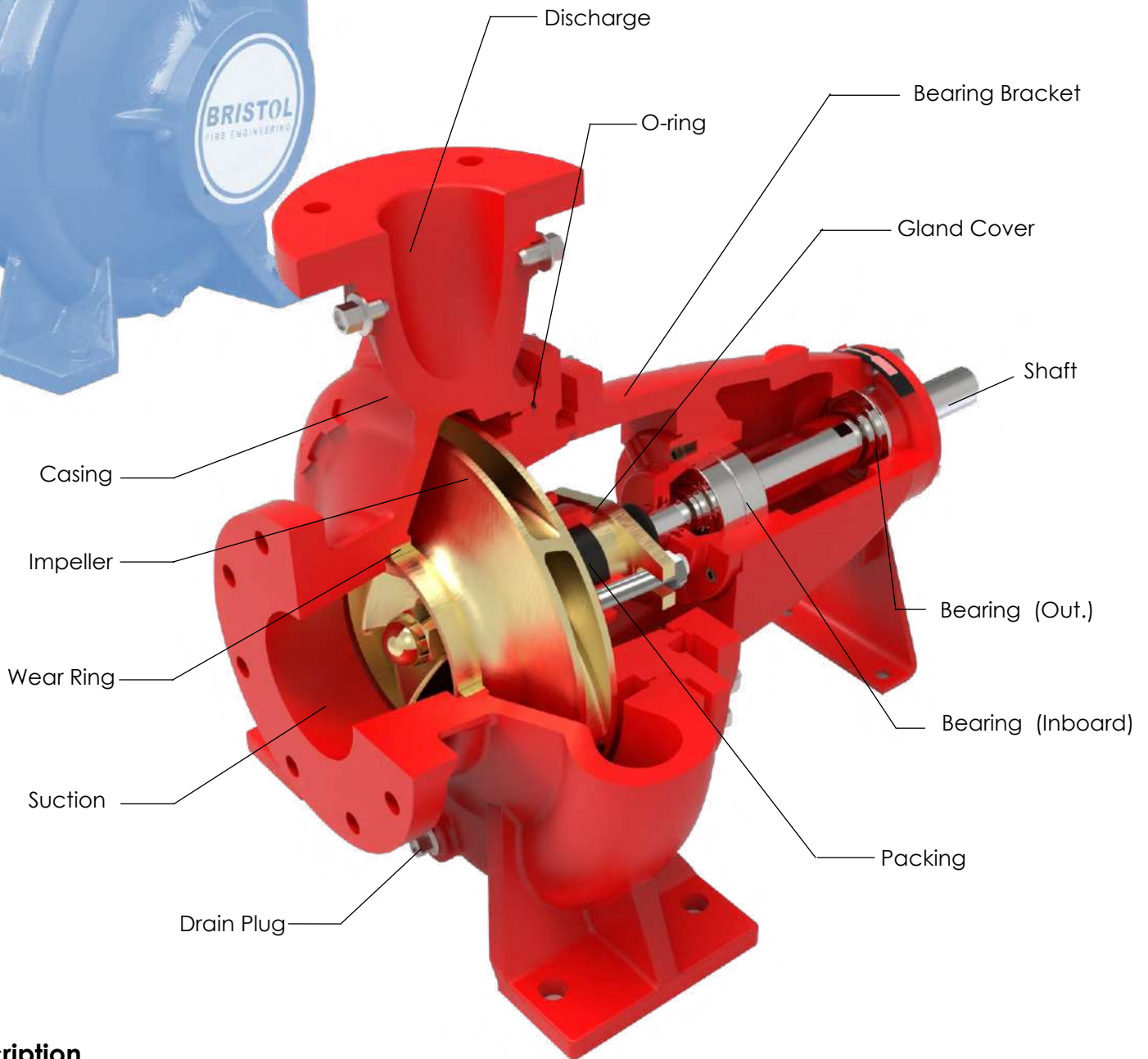

Description

- Casing** - Ductile Iron 65-45-12 - Heavy-duty power frame
- Impeller** - Bronze / SS304
- Wear Ring** - Bronze is standard for the certified ANSI pumps radially split casing with flange connection
- Suction** - Horizontal End Suction ANSI 150# or 300# flange drilling is available based on material selection
- Discharge** - Vertical Centreline Discharge

- Bearing Bracket-** Ductile Iron 65-45-12 - Heavy-duty power frame
- Gland Cover** - Bronze - to house a gland seal
- Shaft** - Stainless Steel - Sleeve shaft as standard for extended seal life
- Bearing (Out.)** - Deep Grooved Ball Bearing
- Bearing (Inb.)** - Deep Grooved Ball Bearing

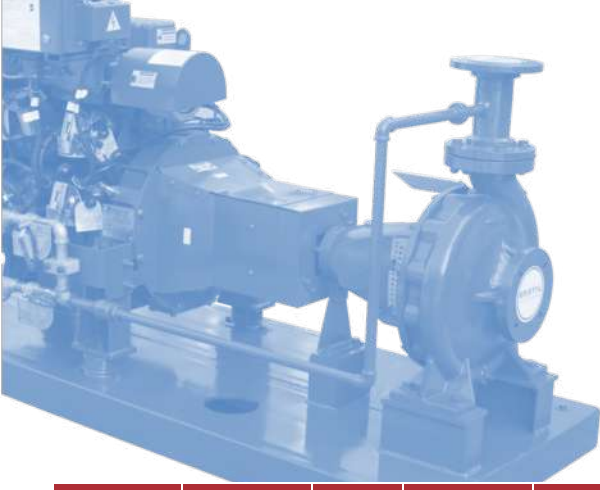

End Suction Pump Selection Chart



Model	Rated Capacity (GPM)	Size (In)	UL Listed Pressure (PSI)	FM Approved Pressure (PSI)	Rated Speed (RPM)
IS32-200	50	2 x 1 1/4	55-85		2800
IS32-200	50	2 x 1 1/4	62-95		2950
IS50-320H	50	2 1/2 x 2	88-142		2400
IS50-320H	50	2 1/2 x 2	103-167		2600
IS32-260	50	2 x 1 1/4	113 - 130		2950
BEP 3X2.5 LP	100	3 x 2 1/2	60-92		2950
BEP 3X2.5 LP	100	3 x 2 1/2	62-95		3000
IS50-320H	100	2 1/2 x 2	87-141		2400
BEP 3X2.5 LP	100	3 x 2 1/2	87-134		3550
IS50-320H	100	2 1/2 x 2	102-166		2600
IS32-260	100	2 x 1 1/4	103 - 125		2950
IS65-260	100	3 x 2 1/2	110-148		2950
IS65-260	100	3 x 2 1/2	113-153		3000
IS50-320H	100	2 1/2 x 2	119-189		2800
IS50-320H	100	2 1/2 x 2	132-210		2950
IS50-320H	100	2 1/2 x 2	178-298		3500
BEP 3X2.5 LP	150	3 x 2 1/2	59-91		2950
BEP 3X2.5 LP	150	3 x 2 1/2	61-94		3000
IS50-320H	150	2 1/2 x 2	84-140		2400
BEP 3X2.5 LP	150	3 x 2 1/2	86-132		3550
IS50-320H	150	2 1/2 x 2	99-165		2600
IS65-260	150	3 x 2 1/2	110-148		2950
IS65-260	150	3 x 2 1/2	113-153		3000
IS50-320H	150	2 1/2 x 2	118-188		2800
IS50-320H	150	2 1/2 x 2	132-209		2950
IS50-320H	150	2 1/2 x 2	177-296		3500
BEP 3X2.5 LP	200	3 x 2 1/2	58-90		2950
BEP 3X2.5 LP	200	3 x 2 1/2	60-93		3000
BEP 3X2.5 LP	200	3 x 2 1/2	85-130		3550
IS65-320H	200	3 x 2 1/2	88-133		2400
IS65-320H	200	3 x 2 1/2	97-181		2800
IS65-320H	200	3 x 2 1/2	104-158		2600
IS65-320H	200	3 x 2 1/2	108-201		2950
IS65-260	200	3 x 2 1/2	109-147		2950
IS65-260	200	3 x 2 1/2	113-152		3000
IS50-320H	200	2 1/2 x 2	113-188		2800
IS50-320H	200	2 1/2 x 2	127-209		2950
IS65-320H	200	3 x 2 1/2	159-290		3500
IS50-320H	200	2 1/2 x 2	173-296		3500
IS80-260	200	4 x 3		111-151	2950
IS80-260	200	4 x 3		115-157	3000
BEP 3X2.5 LP	250	3 x 2 1/2	55-88		2950
BEP 3X2.5 LP	250	3 x 2 1/2	57-91		3000
BEP 3X2.5 LP	250	3 x 2 1/2	83-129		3550
IS65-320H	250	3 x 2 1/2	85-131		2400
IS65-320H	250	3 x 2 1/2	97-181		2800
IS65-320H	250	3 x 2 1/2	102-155		2600
IS65-260	250	3 x 2 1/2	107-146		2950
IS65-320H	250	3 x 2 1/2	107-201		2950
IS65-260	250	3 x 2 1/2	111-151		3000
IS65-320H	250	3 x 2 1/2	157-290		3500
BEP 3X2.5 LP	300	3 x 2 1/2	52-85		2950
BEP 3x2.5 LP	300	3 x 2 1/2	54-88		3000
BEP 4x3 LP	300	4 x 3	55-89		2950
BEP 4x3 LP	300	4 x 3	57-92		3000
BEP 3X2.5 LP	300	3 x 2 1/2	80-126		3550
IS65-320H	300	3 x 2 1/2	82-128		2400
BEP 4x3 LP	300	4 x 3	82-130		3550
IS65-320H	300	3 x 2 1/2	97-181		2800
IS65-320H	300	3 x 2 1/2	98-152		2600
IS65-260	300	3 x 2 1/2	105-144		2950

Model	Rated Capacity (GPM)	Size (In)	UL Listed Pressure (PSI)	FM Approved Pressure (PSI)	Rated Speed (RPM)
IS65-320H	300	3 x 2 1/2	107-201		2950
IS65-260	300	3 x 2 1/2	109-149		3000
IS80-320H	300	4 x 3	143-183		2800
IS65-320H	300	3 x 2 1/2	155-289		3500
IS80-320H	300	4 x 3	159-203		2950
IS80-260	300	4 x 3	167-222	153-206	3550
IS80-260	300	4 x 3		111-150	2950
IS80-260	300	4 x 3		115-156	3000
BEP 4X3 LP	400	4 x 3	54-87		2950
BEP 4X3 LP	400	4 x 3	56-90		3000
BEP 4X3 LP	400	4 x 3	79-127		3550
IS100-320H	400	5 x 4	83-147		2400
IS65-260	400	3 x 2 1/2	99-141		2950
IS100-320H	400	5 x 4	98-172	118-168	2600
IS65-260	400	3 x 2 1/2	103-146		3000
IS80-260	400	4 x 3	105-139	110-149	2950
IS80-260	400	4 x 3	109-144	114-154	3000
IS100-320H	400	5 x 4	110-142		2800
IS100-320H	400	5 x 4	123-158	122-236	2950
IS100-320H	400	5 x 4	133-163	126-244	3000
IS80-320H	400	4 x 3	142-183		2800
IS80-320H	400	4 x 3	158-203		2950
IS80-260	400	4 x 3	165-222	152-206	3550
BEP 4X3 LP	450	4 x 3	53-85		2950
BEP 4X3 LP	450	4 x 3	55-88		3000
BEP 4X3 LP	450	4 x 3	78-126		3550
IS100-320H	450	5 x 4	83-147		2400
IS100-320H	450	5 x 4	98-172		2600
IS100-320H	450	5 x 4	110-142		2800
IS100-320H	450	5 x 4	122-158		2950
IS100-320H	450	5 x 4	133-164		3000
IS80-320H	450	4 x 3	140-182		2800
IS80-320H	450	4 x 3	157-203		2950
BEP 4X3 LP	500	4 x 3	51-84		2950
BEP 4X3 LP	500	4 x 3	53-87		3000
BEP 4X3 LP	500	4 x 3	78-125		3550
IS100-320H	500	5 x 4	82-147		2400
IS100-320H	500	5 x 4	97-172	116-168	2600
IS80-260	500	4 x 3	101-137	108-146	2950
IS80-260	500	4 x 3	106-142	112-152	3000
IS100-320H	500	5 x 4	110-142		2800
IS100-320H	500	5 x 4	122-226	121-235	2950
IS100-320H	500	5 x 4	124-234	125-244	3000
IS80-320H	500	4 x 3	136-182		2800
IS100-260	500	5 x 4	144-212	134-197	3550
IS80-320H	500	4 x 3	155-202		2950
BEP 5X4 HH	500	5 x 4	155-244		2950
IS80-260	500	4 x 3	163-220	150-204	3550
IS100-320H	750	5 x 4	89-166	111-166	2600
IS100-320H	750	5 x 4	104-131		2800
IS100-260	750	5 x 4	113-139	111-143	2950
IS100-260	750	5 x 4	118-144	115-149	3000
IS100-320H	750	5 x 4	119-224	119-233	2950
IS100-320H	750	5 x 4	119-232	123-241	3000
IS100-260	750	5 x 4	140-212	134-195	3550
BEP 5X4 HH	750	5 x 4	149-239		2950
IS100-260	1000	5 x 4	104-131	109-141	2950
IS100-260	1000	5 x 4	109-137	113-146	3000
IS100-260	1000	5 x 4	132 - 208	130-194	3550
BEP 5X4 HH	1000	5 x 4	140-231		2950

BRISTOL

Model/Stage	IS 100-260	Design Pressure/Head	144.00	psi
		Design Flow	500.00	GPM
		Rated Speed	3,550	rpm

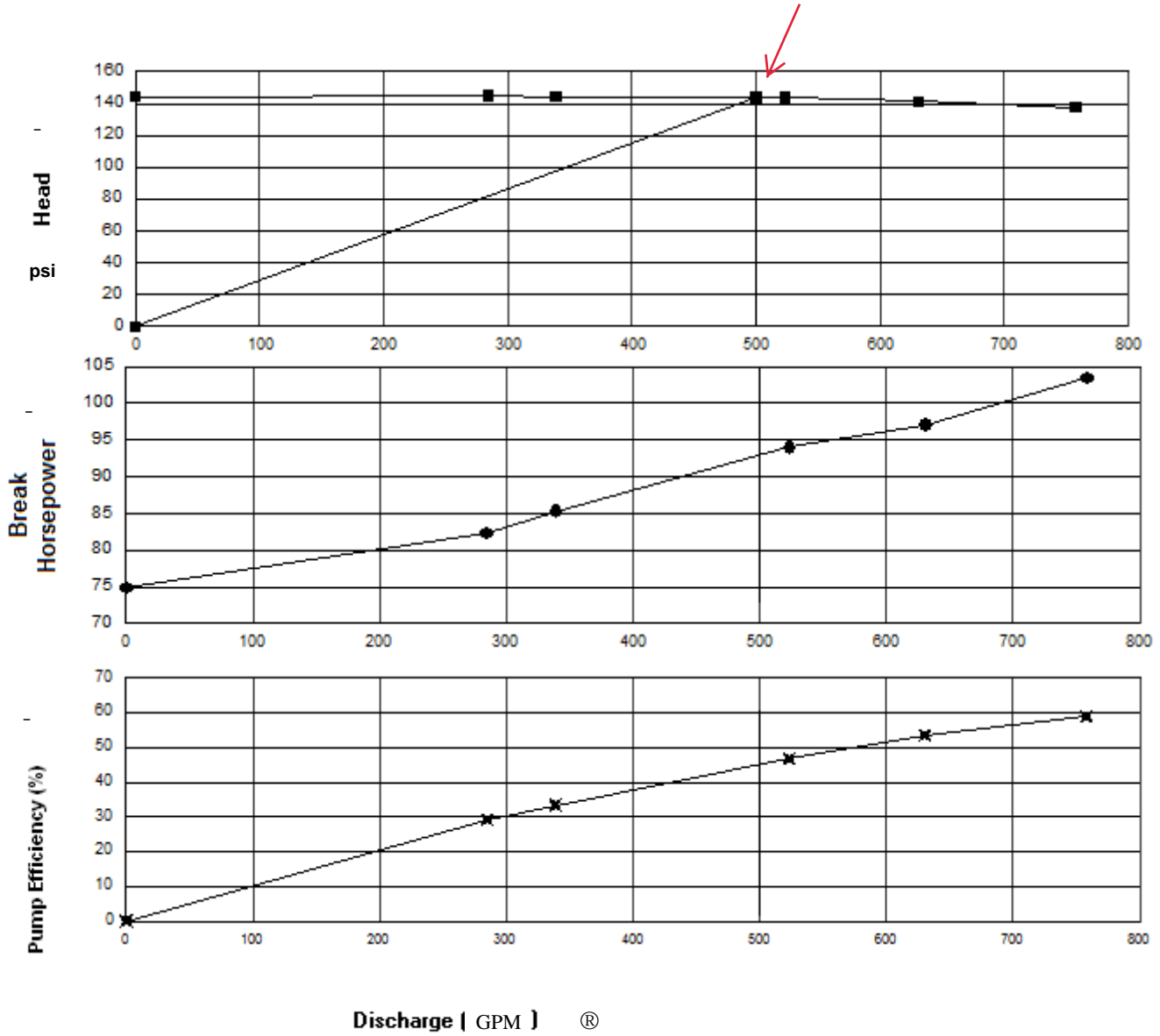

ELECTRIC FIRE PUMP MOTOR DATA

Fire Fighting Solutions Provider

ص.ب: ٧٤٥٨٢ . دبي الامارات العربية المتحدة تيلفون : ٣٤٧٧٠٧٣ / ٣٤٧٢٤٢٦ +٩٧١ ٤ ٣٤٧٢٣٦٣ فاكس : +٩٧١ ٤ ٣٤٧٢٣٦٣

P.O.Box: 74582 Dubai, UAE. Tel : +971 4 3472426 / 3477073 Fax : +971 4 3472363 E-mail: sales@bristol-fire.com, www.bristol-fire.com

Horizontal A.C. Motors

Open Dripproof Enclosure Fire Pump Motors



Horsepower: 1 – 500 HP

Speed Range: 1800 – 3600 RPM

Rated Voltages: 200 through 575 Voltage at 60 Hz

Frame Sizes: 143T – 5012

Insulation: Class F insulation with Class B temperature rise at service factor

Enclosure: Open Dripproof (ODP)

Efficiency Level: Energy Efficient (IE2) and NEMA Premium^{®†} Efficient (IE3)



For fire pump applications per NFPA^{®†} 20 where contaminants are minimal

Product Overview and Options

On January 1, 1998, all fire pump manufacturers were required to have motors UL Listed specifically for Fire Pump applications. At that time, we released the UL Listed Fire Pump Motor line. Fire Pump Motors were designed per UL-1004A (currently UL-1004-5) and met the NFPA 20 “Standard for the Installation of Stationary Pumps for Fire Protection.”

U.S. MOTORS[®] brand ODP fire pump products are fully compliant with federal motor efficiency requirements as described in the Energy Independence and Security Act of 2007 also known as EISA. All fire pump motors provide necessary identifying nameplate data.

On May 14, 2013, Nidec Motor Corporation expanded its UL Listed Fire Pump Motor file (EX5189) to include inverter duty (10:1 variable torque), 500HP or less, and frame sizes 143-5012.

For Nidec Motor Corporation to be able to apply the UL Listed Fire Pump label, motors must meet the following requirements:

- Designed to meet NEMA^{®†} Design "B" parameters per NEMA^{®†} MG1-2014
- Calculated Safe Stall Time must exceed 12 seconds (cold) / 8 seconds (hot)
- Motors designated for Canada must meet CSA-390 Table 2 efficiency values
- 600V or less
- 500HP and lower
- 5012 frame and smaller
- 1.15 service factor (max)

NFPA^{®†}: National Fire Protection Association

A worldwide leader in providing fire, electrical, and life safety to the public since 1986, the mission of the international nonprofit NFPA^{®†} is to reduce the worldwide burden of fire and other hazards on the quality of life by providing and advocating scientifically-based consensus codes and standards, research, training and education. NFPA^{®†} membership totals more than 75,000 individuals from around the world and more than 80 national trade and professional organizations.

For more information, go to www.nfpa.org



Product Overview and Options *(continued)*

Standard Features:

- 1.15 service factor
- Class F insulation, Class B temperature rise at 1.15 service factor (60Hz)
- 40°C Ambient, NEMA^{®†} Design B performance on 60Hz Sine Wave Power
- Rolled steel frame 143-320, Cast iron frame 360-5012
- Aluminum end shields 143-250, Cast iron end shields 320-5012
- Premasked Mylar nameplate 143-320, Stainless steel 360-5012
- Regreaseable bearings 180 Frame & Larger
- Double shielded bearings 140-400, Open On 440 Frame & larger
- Internal bearing caps 400 Frame & Up
- Lifting provisions 210 Frame & Larger
- Catalog models suitable for Wye-Delta Start 250-445 Frame
- Dual voltage catalog models suitable for Part Winding Start (PWS) on low voltage
- 230/460 & 575 Volt catalog models comply with NRCAN Standards
- 230/460V catalog models dual nameplated for 190/380V 50Hz, Next lower horsepower
- Oversized connection diagram, Catalog models “CE” Mark on nameplate
- Vertical “JP” closed coupled pump catalog models (140-365) with drip cover

Options and Accessories:

Nidec Motor Corporation offers the following custom-design options on the U.S. MOTORS[®] brand ODP Fire Pump motor:

- Inverter duty 10:1 variable torque
- 50 Hertz voltages
- 50°C ambient
- C and D flanges
- Special paint
- Space heater
- Winding and bearing thermal protection



Warranty Information

Refer to the U.S. MOTORS[®] website (usmotors.com) for the most up-to-date warranty information.

All Nidec Motor Corporation products shall carry the limited warranty of 12 months from the date of installation, not to exceed 18 months from date of manufacture as specified in Section 5 of Nidec Motor Corporation’s Terms and Conditions of Sale except those specifically listed below, or noted within individual product family pages within this catalog.

	Installed / Manufactured	Installed / Manufactured
ODP Motors 140 - 449 NEMA Frames	Sine Wave Power	VFD Power
Epact	18 / 24 months	12 / 18 months
Premium Efficient & NEMA Premium ^{®†}	36 / 42 months	24 / 30 months
Inverter Duty	36 / 42 months	36 / 42 months
TITAN[®] ODP Motors - 5000 Frame and Larger	Sine Wave Power	VFD Power
Standard Efficient & Energy Efficient	12 / 18 months	12 / 18 months
Premium Efficient	24 / 30 months	18 / 24 months
Inverter Duty	24 / 30 months	24 / 30 months

For additional information, please refer to our Full Line Standard Motor Catalog (FL600) or contact your Nidec Motor Corporation representative.

† All marks shown within this document are properties of their respective owners.

Nidec Motor Corporation, 2015; All Rights Reserved. U.S. MOTORS[®] is a registered trademark of Nidec Motor Corporation. Nidec Motor Corporation trademarks followed by the ® symbol are registered with the U.S. Patent and Trademark Office.



8050 W. Florissant Avenue | St. Louis, MO 63136
Phone: 888-637-7333 | Fax: 866-422-7758



Should be 4pt. with
white space of 4pt width
on either side.

FIRE PUMP MOTORS

BROCHURE



MARATHON®

In 1913, the founders of a new motor company that they named Marathon Electric had a simple vision:

- Serve our customers according to their needs
- Produce the most efficient and long-lasting motors
- Commit to new technology and research
- Expand and diversify into new markets

The company was located in the heartland of America, Wausau, Wisconsin, where it remains today, over one hundred years later. The company continues to be one of the innovators in the motor industry, built on a history of industry first! Marathon engineered, designed, and built the first fire pump motor and we continue to lead the life safety industry with Marine Duty UL fire pump motors, medium voltage, vertical hollow shaft UL fire pump motors, and specialty UL Fire Pump motors.

When a fireman needs a trusted friend in an emergency, he knows Marathon will do the job, offering protection, high performance, and reliability as we have for over one hundred years ... that's a legacy!

PRODUCT LINE

ODP

- Available in NEMA or IEC construction these motors are ideal for in-door applications. Lower cost and longer product life due to lower temperature windings make these a best value option.
- These motors are available from 25-500HP, 2 and 4 poles, Epact Efficiency. All motors are 12 leads for wye-delta or across-the-line start, part winding start is available in single voltage or at lower voltage for dual voltage motors. All motors have 1.15 service factor for all voltages.

TEFC

- Available in NEMA or IEC construction, TEFC motors are ideal for applications in tough environments.
- These motors are available from 25-500HP, 2 and 4 poles, Epact Efficiency. All motors are 12 leads for wye-delta or across the line start, part winding start is available in single voltage or at lower voltage for duo voltage motors. All motors have 1.15 service factor for all voltages.

CLOSE COUPLED PUMP

- Available as JP or JM constructions, these motors are ideal when space is an issue. This integrated design enables a lower system cost.
- 2 and 4 poles, Epact Efficiency. Horizontal or vertical ODP construction.
- All motors have 1.15 service factor for all voltages.

VSS AND VHS

- Vertical solid shaft and hollow shaft constructions are ideal for deep well applications with turbine pumps. These motors are designed to handle the highest thrust loads of this system.
- VSS motors are available from 3-400 HP, 2 to 8 poles and are designed for normal and medium thrust, Epact Efficiency.
- All motors are 12 leads for wye-delta or across the line start, part winding start is available in single voltage or at lower voltage for duo voltage motors. All motors have 1.15 service factor for all voltages.
- VHS motors are available from 7.5HP to 300HP, 2 and 4 poles, WP1, Epact Efficiency.
- All motors are 12 leads for wye-delta or across-the-line start, part winding start is available in single voltage or at lower voltage for dual voltage motors. All motors have 1.15 service factor for all voltages.

MEDIUM VOLTAGE

- Regal also offers Medium Voltage products in NEMA and IEC constructions designed specifically for Fire Pump Applications.
- NEMA Construction, from 200 to 700HP, 2300V & 4000V 50/60HZ, 2 and 4 poles, IP22, 1.15 service factor. IEC Construction, from 185kW to 2800kW, 3kV through 10kV 50HZ & 4kV through 13.8kV 60HZ, 4 poles, IP23.



Scan the QR code
for more information on
Marathon® Fire Pump Motors

UL LISTED MOTORS

NAMEPLATES

- Fire pump motors have two nameplates, the normal nameplate with UL label and special fire pump nameplate with the UL listing for fire pumps.



FIRE PUMP MOTOR INRUSH CURRENTS

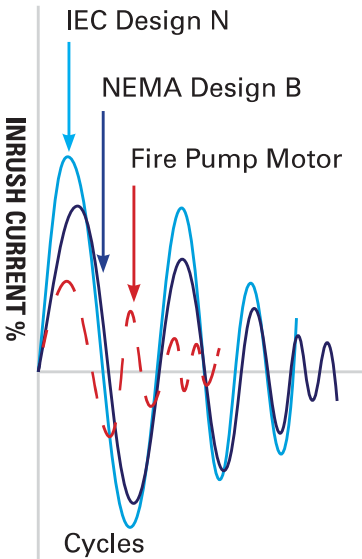

Classification	Locked-Rotor Torque (% Rated-Load Torque)	Breakdown Torque (% Rated-Load Torque)	Locked-Rotor Current (% Rated-Load Current)
UL Fire Pump Motor	70-275*	175-300*	300-600
Design B – Normal locked-rotor torque and normal locked-rotor current	70-275*	175-300*	600-700
IEC 34-12 Design N locked-rotor torques and currents	75-190*	160-200*	800-1000

*Higher values are for motors having lower horsepower ratings.

REGAL WORLD FOOTPRINT *The motor you want, where you are, when you need.*

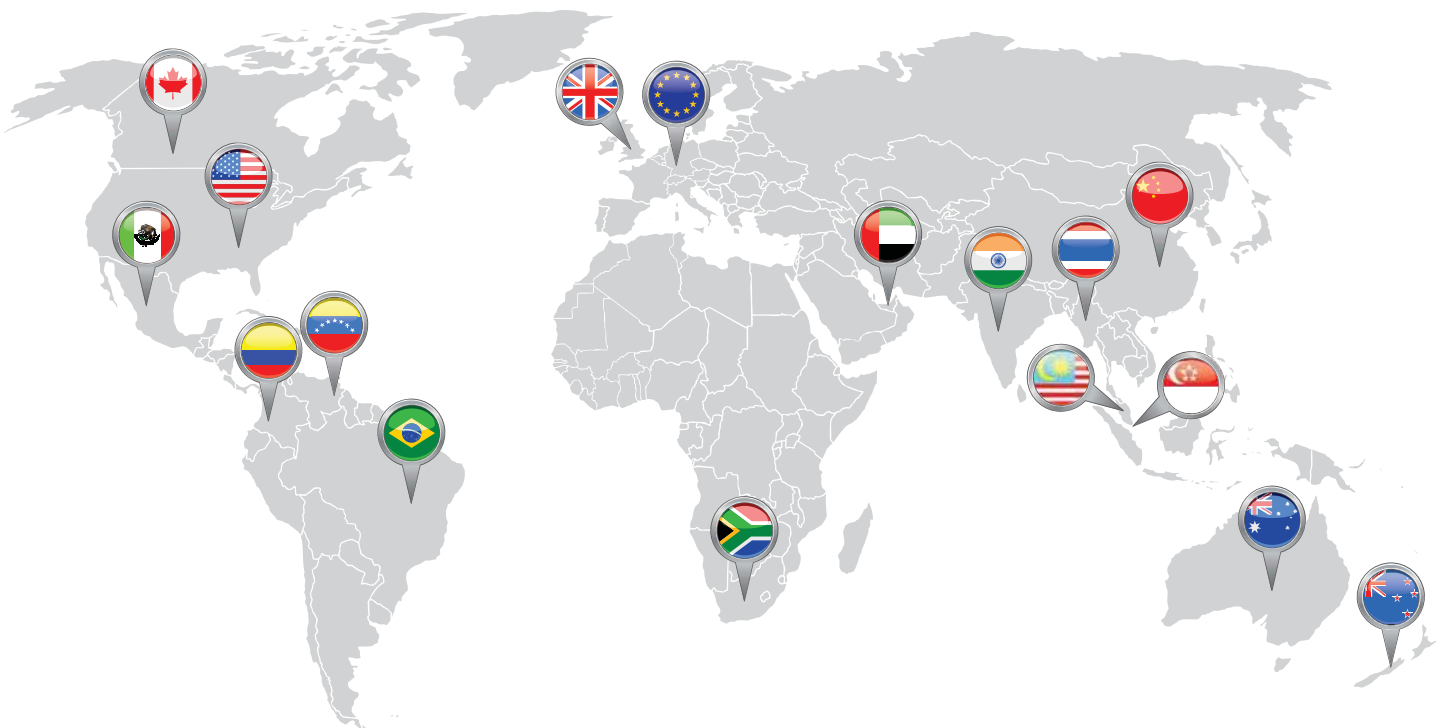

Fire Pump

Motors

■ UL Listed

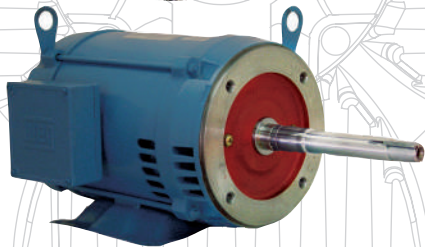
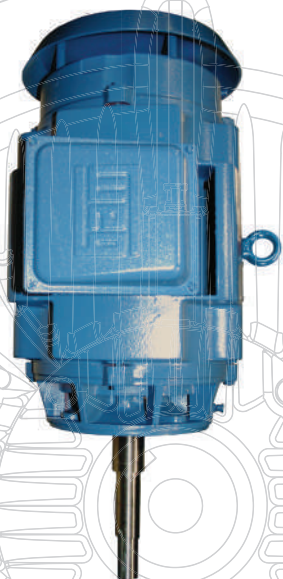
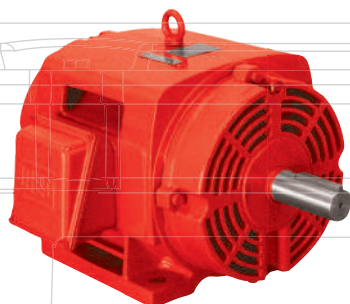

UL LISTED
68YN
FIRE PUMP MOTOR
EX5990

UL Listed

Fire Pump Motors – ODP

Three Phase – Foot Mount and Flange Mount

WEG High Efficiency motors are specifically designed to meet or exceed all EISA 2007 requirements for energy efficiency. They are certified by the Department of Energy with our Certificate of Compliance number CC029A.

These Fire Pump Duty (ODP) motors are designed for environments where dirt and moisture are minimal and provide maximum ventilation and heat dissipation. Design B torque and high efficiency design from 143T through 449T frames.



STANDARD FEATURES

- Efficiency Certification number CC029A according to US Department of Energy Regulations for EISA2007 Efficiency levels
- 2 pole
- Voltage: 380 - 400 (YY) / 440 - 460 (D) - 60Hz // 380 - 400 -415 (D) - 50 Hz
- Open Drip Proof (ODP)
- NEMA Dimensions
- NEMA design 'B' ratings
- Service Factor: 1.15
- Class 'F' insulation for all frames, Class B rise
- 1045 heat treated and stress relieved carbon steel shaft
- Motors are supplied with ball bearings as standard.
- F1 mount (also available flanged motors)
- Paint: Enamel alkyd resin base
- Color: Red – RAL3000
- NPT threaded terminal box
- Stainless steel nameplate – laser etched
- Meets NEMA MG-1 Part 31 for Inverter Use at 1000:1 Variable Torque
- 50°C ambient

OPTIONAL FEATURES

- Cable glands
- Special voltags
- Cast iron NEMA C-Flange or D-Flange (D-Flange only for frames 254T and up)
- Specially designed shaft
- Second shaft end
- Thermistors, thermostats or RTD's (PT100)
- Roller bearings on drive end
- IEC metric frames (on request) for frame 160 up to 280
- Insulated Bearings
- Shaft Grounding Ring

Frame – Specific Features

For Frame 143/5T only

- Welded steel plate frames (welded feet)
- Cast iron endshields fixed with through bolt construction
- 'ZZ' bearings (double shielded)
- Degree of protection : IP21

182/4T and 213/5T Frames only

- Aluminum endshields and terminal box
- Cooling system with finned rotor

For Frame 254/6T and Up

- Cast iron frames
- Cast iron endshields and terminal box
- Cooling system with finned rotor
- Regreasable bearings positive pressure lubrication system
- Degree of protection : IP23

UL File number

EX5990

located on Fire Pump Label

WEG's Fire Pump motors are UL listed (UL 1004A) for Fire Pump applications in accordanc with NFPA 20. In addition, they feature a Class F insulation system and 1.15 service factor.

SUITABLE FOR

FIRE PUMP

APPLICATIONS

DRIVEN

BY VFD'S 10:1

SPEED RANGE (6 TO

60HZ) AND SF 1.15

FIRE PUMP MOTOR

Note: All motors are tested according to IEEE 112 std. - Method 'B' or C390 CSA. All WEG motors are energy efficiency verified by UL in addition to the DOE.





www.weg.net

WEG Worldwide Operations

ARGENTINA

San Francisco - Cordoba
Phone: +54 3564 421484
info-ar@weg.net

Cordoba - Cordoba
Phone: +54 351 4641366
weg-morbe@weg.com.ar

Buenos Aires
Phone: +54 11 42998000
ventas@pulverlux.com.ar

AUSTRALIA

Scoresby - Victoria
Phone: +61 3 97654600
info-au@weg.net

AUSTRIA

Markt Piesting - Wiener
Neustadt-Land
Phone: +43 2633 4040
watt@wattdrive.com

BELGIUM

Nivelles - Belgium
Phone: +32 67 888420
info-be@weg.net

BRAZIL

Jaraguá do Sul - Santa Catarina
Phone: +55 47 32764000
info-br@weg.net

CHILE

La Reina - Santiago
Phone: +56 2 27848900
info-cl@weg.net

CHINA

Nantong - Jiangsu
Phone: +86 513 85989333
info-cn@weg.net

Changzhou - Jiangsu
Phone: +86 519 88067692
info-cn@weg.net

COLOMBIA

San Cayetano - Bogota
Phone: +57 1 4160166
info-co@weg.net

ECUADOR

El Batán - Quito
Phone: +593 2 5144339
ceccato@weg.net

FRANCE

Saint-Quentin-Fallavier - Isère
Phone: +33 4 74991135
info-fr@weg.net

GERMANY

Türnich - Kerpen
Phone: +49 2237 92910
info-de@weg.net

Balingen - Baden-Württemberg
Phone: +49 7433 90410
info@weg-antriebe.de

Homburg (Efze) - Hesse
Phone: +49 5681 99520
info@akh-antriebstechnik.de

GHANA

Accra
Phone: +233 30 2766490
info@zestghana.com.gh

INDIA

Bangalore - Karnataka
Phone: +91 80 41282007
info-in@weg.net

Hosur - Tamil Nadu
Phone: +91 4344 301577
info-in@weg.net

ITALY

Cinisello Balsamo - Milano
Phone: +39 2 61293535
info-it@weg.net

JAPAN

Yokohama - Kanagawa
Phone: +81 45 5503030
info-jp@weg.net

MALAYSIA

Shah Alam - Selangor
Phone: +60 3 78591626
info@wattdrive.com.my

MEXICO

Huehuetoca - Mexico
Phone: +52 55 53214275
info-mx@weg.net

Tizayuca - Hidalgo
Phone: +52 77 97963790

NETHERLANDS

Oldenzaal - Overijssel
Phone: +31 541 571080
info-nl@weg.net

PERU

La Victoria - Lima
Phone: +51 1 2097600
info-pe@weg.net

PORTUGAL

Maia - Porto
Phone: +351 22 9477700
info-pt@weg.net

RUSSIA and CIS

Saint Petersburg
Phone: +7 812 363 2172
sales-wes@weg.net

SOUTH AFRICA

Johannesburg
Phone: +27 11 7236000
info@zest.co.za

SPAIN

Coslada - Madrid
Phone: +34 91 6553008
wegiberia@wegiberia.es

SINGAPORE

Singapore
Phone: +65 68589081
info-sg@weg.net

Singapore
Phone: +65 68622220
watteuro@watteuro.com.sg

SCANDINAVIA

Mölnlycke - Sweden
Phone: +46 31 888000
info-se@weg.net

UK

Redditch - Worcestershire
Phone: +44 1527 513800
info-uk@weg.net

UNITED ARAB EMIRATES

Jebel Ali - Dubai
Phone: +971 4 8130800
info-ae@weg.net

USA

Duluth - Georgia
Phone: +1 678 2492000
info-us@weg.net

Minneapolis - Minnesota
Phone: +1 612 3788000

VENEZUELA

Valencia - Carabobo
Phone: +58 241 8210582
info-ve@weg.net



WEG Middle East FZE
The Galleries 3, LOB GB03, 8th Floor
Office No. GB030801, P.O.Box 262508
Dubai, United Arab Emirates
Email: info-ae@weg.net
www.weg.net/ae

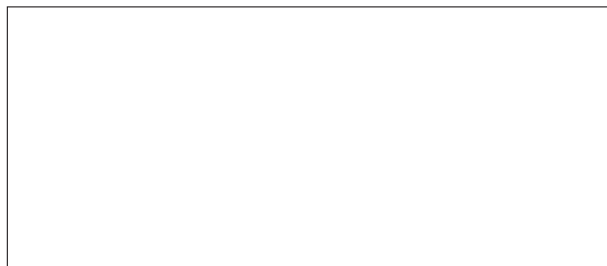

ELECTRIC FIRE PUMP CONTROLLER DATA

Fire Fighting Solutions Provider

ص.ب: ٧٤٥٨٢ . دبي الامارات العربية المتحدة تيلفون: ٣٤٧٧٠٧٣ / ٣٤٧٢٤٢٦ +٩٧١ ٤ ٣٤٧٢٣٦٣ فاكس: +٩٧١ ٤ ٣٤٧٢٣٦٣

P.O. Box 74582 Dubai, UAE. Tel: +971 4 3472426 / 3477073. Fax: +971 4 3472363. E-mail: info@hritel-fire.com, www.hritel-fire.com



TORNATECH

Project: _____

Customer: _____

Engineer: _____

Pump Manufacturer: _____

Technical Data Submittal Document

Model GPY

Full Service Reduced Voltage
Wye-delta Open
Electric Fire Pump Controller



Contents:

Data Sheets
Dimensional Data
Wiring Schematics
Field Connections

Note: The drawings included in this package are for controllers covered under our standard offering. Actual AS BUILT drawings may differ from what is shown in this package.



N.Y.C.
APPROVED



February 2019

From normal incoming power through Disconnecting Means (IS/CB)*

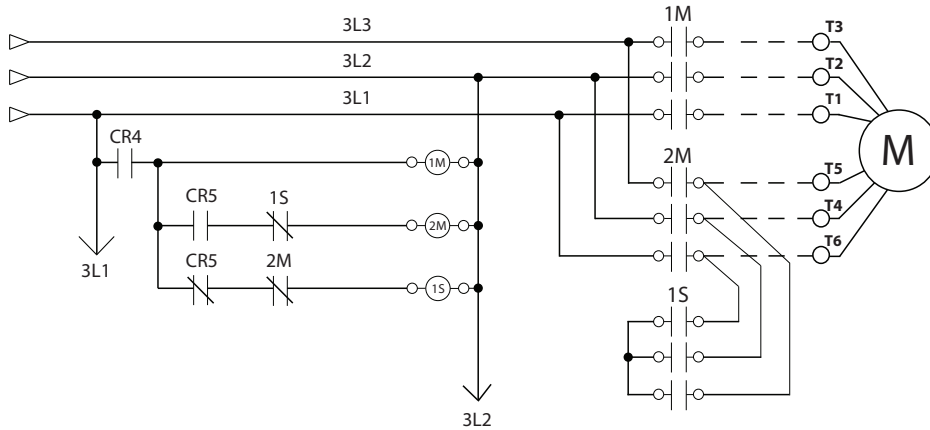

Standard, Listings, Approvals and Certifications	Built to NFPA 20 (latest edition)		
	Underwriters Laboratory (UL)	<ul style="list-style-type: none"> • UL218 - Fire Pump Controllers • CSA C22.2 No. 14 Industrial Control Equipment 	
	FM Global	Class 1321/1323	
	New York City	Accepted for use in the City of New York by the Department of Buildings	
	Seismic Certification	See page 7 for details	
	Optional		
<input type="checkbox"/> CE Mark	Various EN, IEC & CEE directives and standards		
Enclosure	Protection Rating		
	<input type="checkbox"/> Standard: NEMA 2 (IP31)		
	Optional		
	<input type="checkbox"/> NEMA 12 <input type="checkbox"/> NEMA 3 <input type="checkbox"/> NEMA 3R <input type="checkbox"/> NEMA 4	<input type="checkbox"/> NEMA 4X-304 sst painted <input type="checkbox"/> NEMA 4X-304 sst brushed finish <input type="checkbox"/> NEMA 4X-316 sst painted <input type="checkbox"/> NEMA 4X-316 sst brushed finish	<input type="checkbox"/> IP54 <input type="checkbox"/> IP55 <input type="checkbox"/> IP65 <input type="checkbox"/> IP66
	Accessories <ul style="list-style-type: none"> • Bottom entry gland plate • Lifting Lugs • Keylock handle 		Paint Specifications <ul style="list-style-type: none"> • Red RAL3002 • Powder coating • Glossy textured finish

Shortcircuit Withstand Rating	200V to 208V 60Hz	220V to 240V 60Hz	380V to 416V 50 Hz / 60Hz	440V to 480V 60Hz	575V to 600V 60Hz
	HP (kw)				
<input type="checkbox"/> Standard 100kA	5-150 (3.7 - 110)	5-200 (3.7 - 147)	5-300 (3.7 - 220)	5-400 (3.7 - 335)	n/a
<input type="checkbox"/> Optional 150kA					
<input type="checkbox"/> Standard 50kA	200 (147)	250 (184)	350 - 450 (257-335)	450-500 (373)	5-500 (3.7- 373)
<input type="checkbox"/> Optional 100kA	n/a	n/a	n/a	450-500	

*Please see Disconnecting Means details on page 3



Ambient Temperature Rating	Standard: <input type="checkbox"/> 4°C to 40°C / 39°F to 104°F Optional: <input type="checkbox"/> 4°C to 55°C / 39°F to 131°F Controllers built in Dubai, UAE (Tornatech FZE) are supplied standard with 55°C rating.
Surge Suppression	Surge arrestor rated to suppress surges above line voltage
Disconnecting Means	<ul style="list-style-type: none"> • Isolating switch and circuit breaker assembly: <ul style="list-style-type: none"> - Door interlocked in the ON position - Isolating switch rated not less than 115% of motor full load current - Circuit breaker continuous rating not less than 115% of motor full load current - Overcurrent sensing non-thermal type, magnetic only - Instantaneous trip setting of not more than 20 times the motor full load current • Common flange mounted operating handle
Service Entrance Rating	Suitable as service entrance equipment
Emergency Start Handle	<ul style="list-style-type: none"> • Flange mounted • Pull and latch activation • Integrated limit switch • Across the line start (direct on line)
Locked Rotor Protector	<ul style="list-style-type: none"> • Operate shunt trip to open circuit breaker • Factory set at 600% of motor full load current • Trip between 8 and 20 seconds
Electrical Readings	<ul style="list-style-type: none"> • Voltage phase to phase (normal power) • Amperage of each phase when motor is running
Pressure Readings	<ul style="list-style-type: none"> • Continuous system pressure display • Cut-in and Cut-out pressure settings
Pressure and Event recorder	<ul style="list-style-type: none"> • Pressure readings with date stamp • Event recording with date stamp • Under regular maintained operation, events are stored in memory for the life of the controller. • Data viewable on operator interface display screen • Downloadable by USB port to external memory device
Pressure Sensing	<ul style="list-style-type: none"> • Pressure transducer and run test solenoid valve assembly for fresh water application • Pressure sensing line connection 1/2" Female NPT • Drain connection 3/8" • Rated for 0-500PSI working pressure (standard display at 0-300PSI) • Externally mounted with protective cover



Audible Alarm	4" alarm bell - 85 dB at 10ft. (3m)
Visual Indications	<ul style="list-style-type: none"> • Power available • Motor run • Periodic test • Manual start • Deluge valve start • Remote automatic start • Remote manual start • Emergency start • Pump on demand/Automatic start • Pump room temperature (°F or °C) • Lockout
Visual & Audible Alarms	<p>Visual</p> <ul style="list-style-type: none"> • Control voltage not healthy • Invalid cut-in • Lock rotor current • Loss of power • Low ambient temperature • Low water level • Motor trouble • Phase reversal (normal power) • Overcurrent • Overvoltage • Phase loss L1 • Phase loss L2 • Phase loss L3 • Phase unbalanced • Pressure transducer fault detected • Pump on demand • Pump room alarm • Service required • Undercurrent • Undervoltage • Check weekly test solenoid • Weekly test cut-in reached <p>Audible and visual</p> <ul style="list-style-type: none"> • Fail to start
Remote Alarm Contacts	<p>DPDT-8A-250V.AC</p> <ul style="list-style-type: none"> • Power available • Phase reversal • Motor run • Common pump room alarm (field re-assignable)** <ul style="list-style-type: none"> • Overvoltage • Undervoltage • Phase unbalance • Low pump room temperature • High pump room temperature • Common motor trouble (field re-assignable)** <ul style="list-style-type: none"> • Overcurrent • Fail to start • Undercurrent • Ground fault • Free (field programmable)**

**Tornatech reserves the right to use any of these three alarm points for special specific application requirements.



ViZiTouch V2 Operator Interface	<ul style="list-style-type: none"> • Embedded microcomputer with software PLC logic • 7.0" color touch screen (HMI technology) • Upgradable software • Multi-language 			
Communication Protocol Capability	<ul style="list-style-type: none"> • Protocol: Modbus • Connection type: Shielded female connector RJ45 • Frame Format: TCP/IP • Addresses: See bulletin MOD-GPx 			
Operation	Automatic Start	<ul style="list-style-type: none"> • Start on pressure drop • Remote start signal from automatic device • Deluge valve start 		
	Manual Start	<ul style="list-style-type: none"> • Start pushbutton • Run test pushbutton • Remote start from manual device 		
	Stopping	<ul style="list-style-type: none"> • Manual with Stop pushbutton • Automatic after expiration of minimum run timer *** 		
	Timers	Field Adjustable & Visual Countdown	<ul style="list-style-type: none"> • Minimum run timer ***(off delay) • Sequential start timer (on delay) • Periodic test timer 	
	Actuation	Visual Indication	<ul style="list-style-type: none"> • Pressure • Non-pressure 	
	Mode		<ul style="list-style-type: none"> • Automatic • Non-automatic 	

***Can only be used if approved by the AHJ



Seismic Certification	Seismic Certification Company	TRU Compliance, LLC A Tobalski Watkins Affiliate					TWEI Project No.: 15014				
	Mounting details	Rigid base and wall mounting									
	Seismic Information	Building Code	Test Criteria	Seismic Parameters	S_{DS}	z/h	I_P	A_{FLX-H}	A_{RIG-H}	A_{FLX-V}	A_{RIG-V}
	IBC 2015, CBC 2016	ICC-ES AC156	ASCE 7-10 Chapter 13	2.0	1.0	1.5	3.20	2.40	1.33	0.53	
				3.2	0.0	1.5	3.20	1.28	2.13	0.85	

RRS for Nonstructural Components Testing

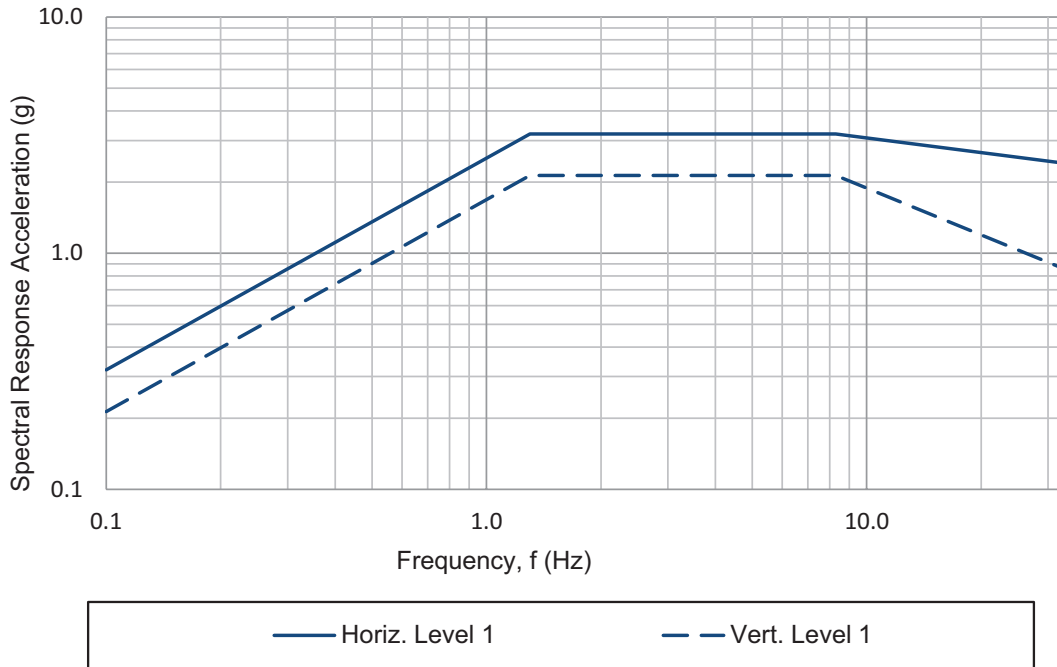

Notes:

- Components are tested in accordance with ICC-ES AC156, IBC 2015 & CBC 2016.
- OSHPD Special Seismic Certification Preapproval (OSP)



<input type="checkbox"/> A4	Flow switch provision	<input type="checkbox"/> C18	High water reservoir level c/w visual indication and alarm contact (DPDT)
<input type="checkbox"/> A8	Foam pump application w/o pressure transducer and run test solenoid valve.	<input type="checkbox"/> C19	Emergency start alarm contact (DPDT)
<input type="checkbox"/> A9	Low zone pump control function	<input type="checkbox"/> C20	Manual start alarm contact (DPDT)
<input type="checkbox"/> A10	Middle zone pump control function	<input type="checkbox"/> C21	Deluge valve start alarm contact (DPDT)
<input type="checkbox"/> A11	High zone pump control function	<input type="checkbox"/> C22	Remote automatic start alarm contact (DPDT)
<input type="checkbox"/> A13	Non-pressure actuated controller w/o pressure transducer and run test solenoid valve	<input type="checkbox"/> C23	Remote manual start alarm contact (DPDT)
<input type="checkbox"/> A16	Lockout/interlock circuit from equipment installed inside the pump room	<input type="checkbox"/> C24	High pump room temperature alarm contact (DPDT)
<input type="checkbox"/> B11	Built in alarm panel (120V.AC supervisory power) providing indication for: • Audible alarm & silence pushbutton for motor run, phase reversal, loss of phase. • Pilot lights for loss of phase & supervisory power available	<input type="checkbox"/> C25	Second set of standard alarm contacts (DPDT) (Typical for city of Los Angeles and Denver)
<input type="checkbox"/> B11B	Built in alarm panel same as B11 but 220-240VAC supervisory power	<input type="checkbox"/> Cx	Additional visual and alarm contact (Specify function) (DPDT)
<input type="checkbox"/> B19A	High motor temperature c/w thermostat relay and alarm contacts (DPDT)	<input type="checkbox"/> D1	Low suction pressure transducer for fresh water rated at 0-300PSI with visual indication and alarm contact
<input type="checkbox"/> B19B	High motor temperature c/w PT100 relay and alarm contacts (DPDT)	<input type="checkbox"/> D1A	Low suction pressure transducer for sea water rated at 0-300PSI with visual indication and alarm contact
<input type="checkbox"/> B21	Ground fault alarm detection c/w visual indication and alarm contact (DPDT)	<input type="checkbox"/> D5	Pressure transducer and run test solenoid valve for fresh water rated for 0-500PSI (for factory calibration purposes only)
<input type="checkbox"/> C1	Extra motor run alarm contact (DPDT)	<input type="checkbox"/> D5D	Pressure transducer and run test solenoid valve for sea water rated for 0-500PSI
<input type="checkbox"/> C4	Periodic test alarm contact (DPDT)	<input type="checkbox"/> D10	Omit mounting feet (when applicable)
<input type="checkbox"/> C6	Low discharge pressure alarm contact (DPDT)	<input type="checkbox"/> D13	High withstand rating for (normal power section) • 208V to 480V = 150kA • 600V = 100kA
<input type="checkbox"/> C7	Low pump room temperature alarm contact (DPDT)	<input type="checkbox"/> D14	Anti-condensation heater & thermostat
<input type="checkbox"/> C10	Low water reservoir level alarm contact (DPDT)	<input type="checkbox"/> D14A	Anti-condensation heater & humidistat
<input type="checkbox"/> C11	High electric motor temperature alarm contact (DPDT)	<input type="checkbox"/> D14B	Anti-condensation heater & thermostat & humidistat
<input type="checkbox"/> C12	High electric motor vibration c/w visual indication and alarm contact (DPDT)	<input type="checkbox"/> D15	Tropicalization
<input type="checkbox"/> C14	Pump on demand / automatic start alarm contact (DPDT)	<input type="checkbox"/> D18	CE Mark with factory certificate
<input type="checkbox"/> C15	Pump fail to start alarm contact (DPDT)	<input type="checkbox"/> D26	Modbus with RTU frame format and RS485 connection
<input type="checkbox"/> C16	Control voltage healthy alarm contact (DPDT)	<input type="checkbox"/> D27	Motor heater connection (external single phase power source and heater on/off contact)
<input type="checkbox"/> C17	Flow meter valve loop open c/w visual indication and alarm contact (DPDT)	<input type="checkbox"/> D27A	Motor heater connection (internal single phase power source and heater on/off contact)

Note: Options chosen from this page are not electrically represented on the wiring schematics in this submittal package.



<input type="checkbox"/> D28	Customized drawing set
<input type="checkbox"/> D34A	Field programmable I/O board - 5 Input / 5 output

<input type="checkbox"/> L01	Other language and English (bilingual)
<input type="checkbox"/> L02	French
<input type="checkbox"/> L03	Spanish
<input type="checkbox"/> L04	German
<input type="checkbox"/> L05	Italian
<input type="checkbox"/> L06	Polish
<input type="checkbox"/> L07	Romanian
<input type="checkbox"/> L08	Hungarian
<input type="checkbox"/> L09	Slovak
<input type="checkbox"/> L10	Croatian
<input type="checkbox"/> L11	Czech
<input type="checkbox"/> L12	Portuguese
<input type="checkbox"/> L13	Dutch
<input type="checkbox"/> L14	Russian
<input type="checkbox"/> L15	Turkish
<input type="checkbox"/> L16	Swedish
<input type="checkbox"/> L17	Bulgarian
<input type="checkbox"/> L18	Thai
<input type="checkbox"/> L19	Indonesian
<input type="checkbox"/> L20	Slovenian
<input type="checkbox"/> L21	Danish
<input type="checkbox"/> L22	Greek
<input type="checkbox"/> L23	Arabic
<input type="checkbox"/> L24	Hebrew
<input type="checkbox"/> L25	Chinese

Additional Options:

Note: Options chosen from this page are not electrically represented on the wiring schematics in this submittal package.

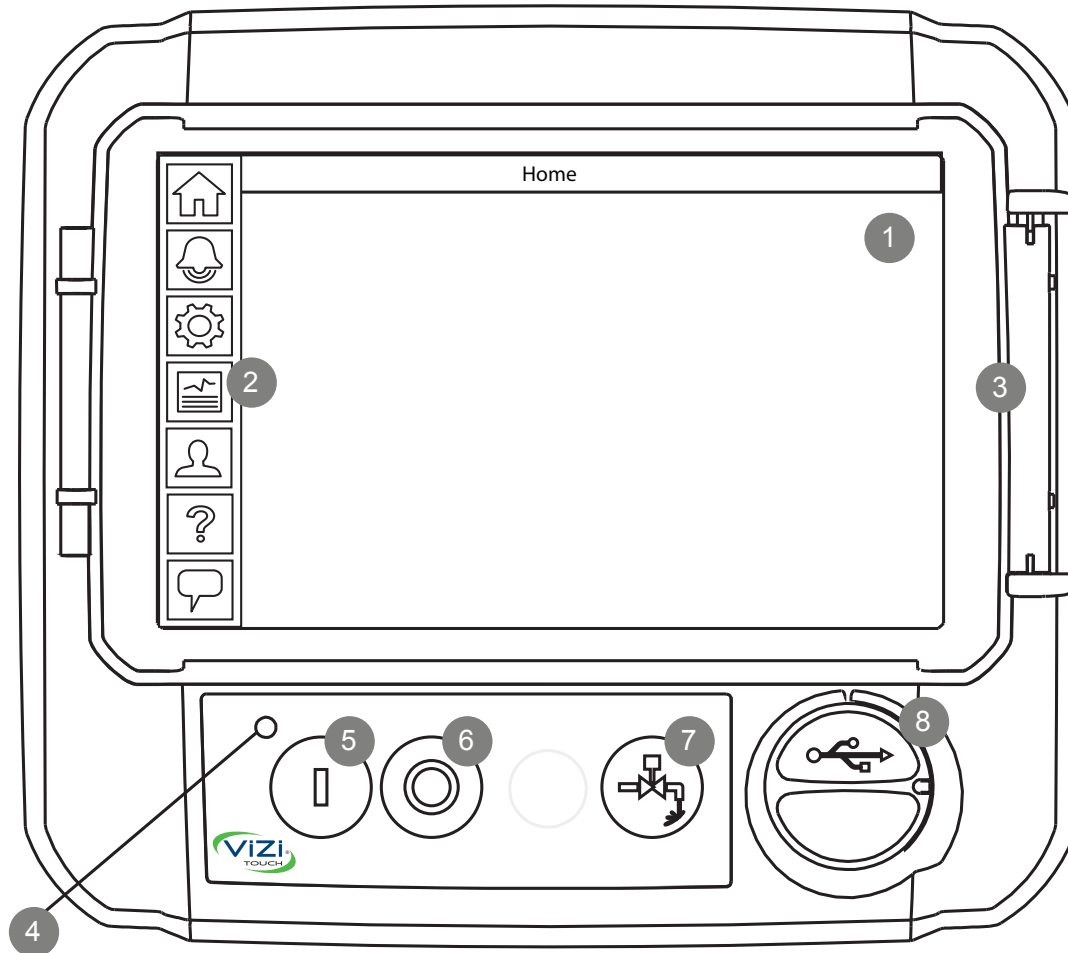
ViZiTouch V2 Operator Interface

- | | |
|------------------------|--------------------------|
| 1 - Color touch screen | 3 - Screen protector |
| 2 - Onscreen menu | 4 - Power LED (3 colors) |
| • HOME page | 5 - START button |
| • ALARM page | 6 - STOP button |
| • CONFIGURATION page | 7 - RUN TEST button |
| • HISTORY page | 8 - USB port |
| • SERVICE page | |
| • MANUAL page | |
| • LANGUAGES page | |

Electric Fire Pump Controller

Model: GPA/GPY

Dimensions

Built to the latest edition of the NFPA 20 standard

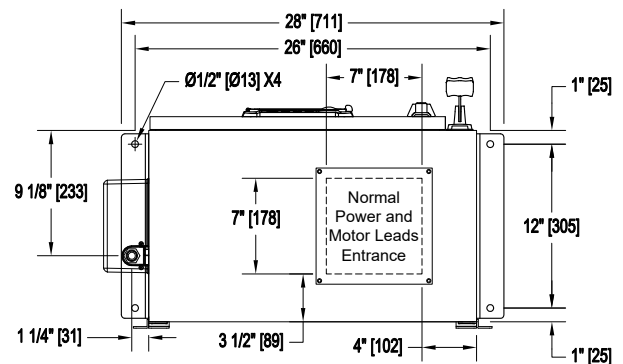
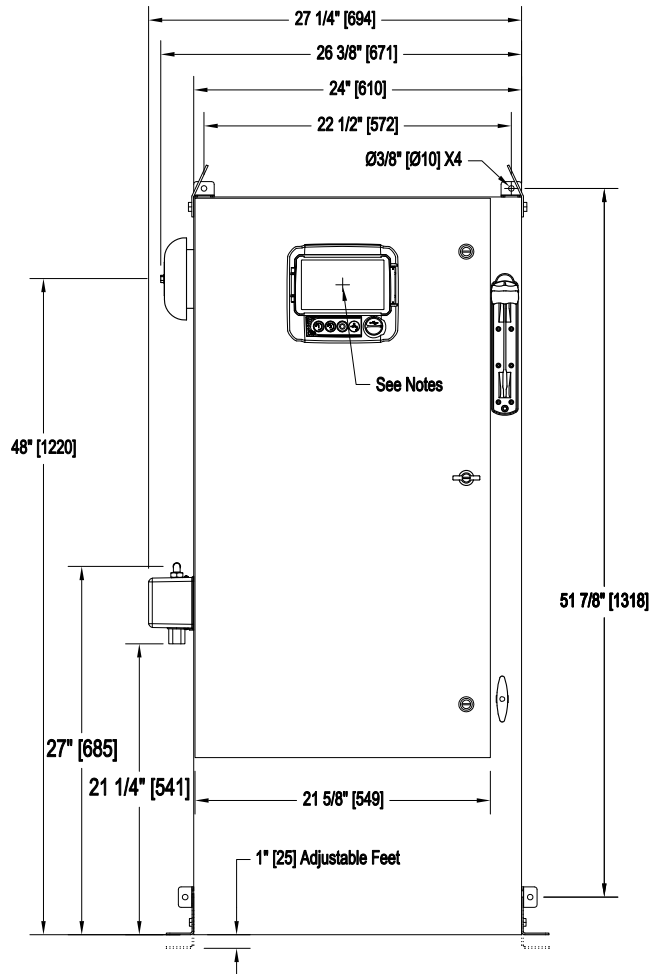
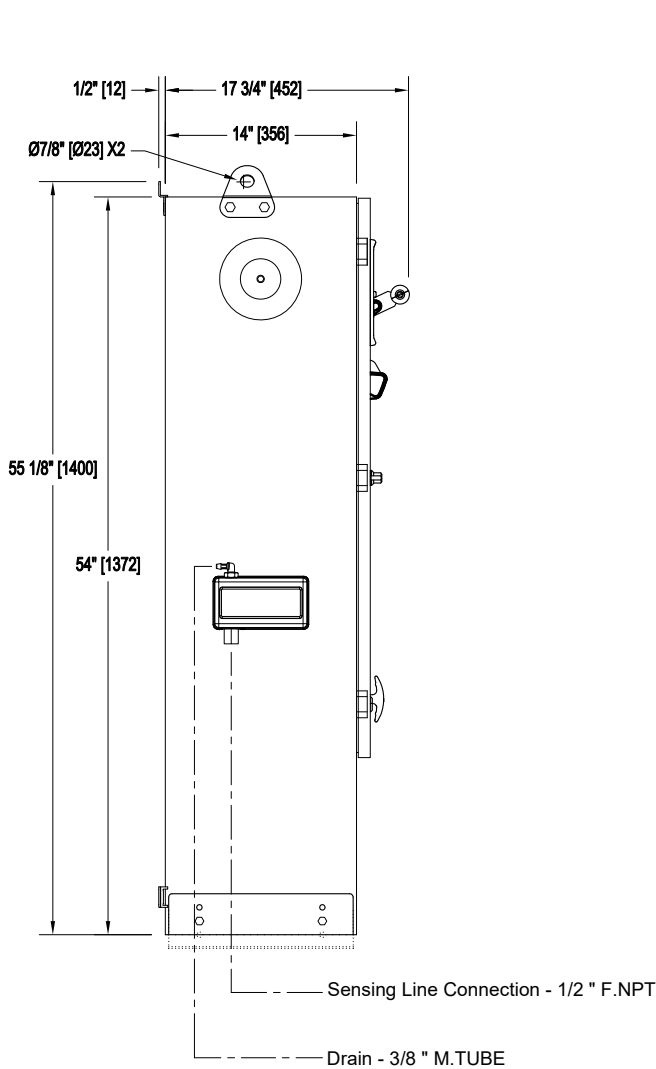

Voltage	Min HP	Max HP
208	40	60
220 - 240	40	60
380 - 400 - 415	75	125
440 - 480	75	150
600	100	150

Notes:

- Standard NEMA: NEMA 2
- Standard paint : textured red RAL 3002.
- All dimensions are in inches [millimeters].
- Center of ViZiTouch screen: 47-5/8" [1208] from Bottom.
- Bottom conduit entrance through removable gland plate recommended.
- Use watertight conduit and connector only.
- Protect equipment against drilling chips.
- Door swing equal to door width.
- Seismic mounting to be rigid wall and base only.

Drawing for information only.
 Manufacturer reserves the right to modify this drawing without notice.
 Contact manufacturer for "As Built" drawing.

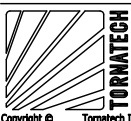
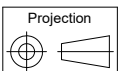

REV.	DESCRIPTION	DD/MM/YY	Drawing number
2.	New Logo	10/05/18	GPX-DI261 /E
1.	Valve Change	21/11/17	
0.	First issue	16/11/16	

Electric Fire Pump Controller Reduced Voltage / Wye-Delta (Open Transition)

Model: GPY

Wiring schematic

Built to the latest edition of the NFPA 20 standard

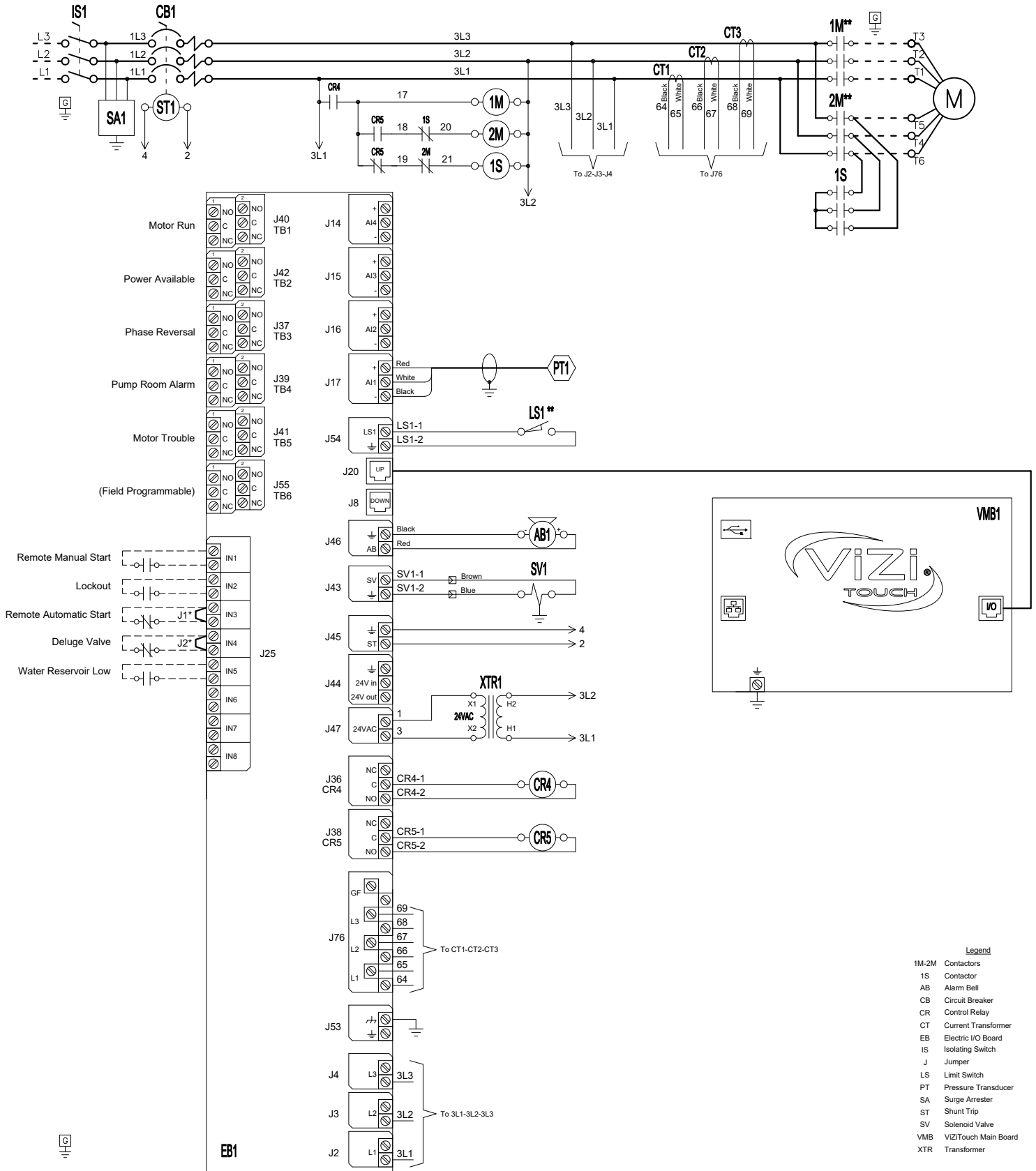

* Remove jumper to use this feature
** Contact closes when emergency start is in "ON" position

Drawing for information only.
Manufacturer reserves the right to modify this drawing without notice.
Contact manufacturer for "As Built" drawing.

- Legend**
- 1M-2M Contactors
 - 1S Contactor
 - AB Alarm Bell
 - CB Circuit Breaker
 - CR Control Relay
 - CT Current Transformer
 - EB Electric I/O Board
 - IS Isolating Switch
 - J Jumper
 - LS Limit Switch
 - PT Pressure Transducer
 - SA Surge Arrester
 - ST Shunt Trip
 - SV Solenoid Valve
 - VMB VIZITouch Main Board
 - XTR Transformer



REV.	DESCRIPTION	DD/MM/YY	Drawing number
2	Update Logo	23/04/18	GPY-WS600 /E
1	Removed (fail safe) text from Power Available relay	20/02/17	
0	First issue	10/11/16	

Power Terminals

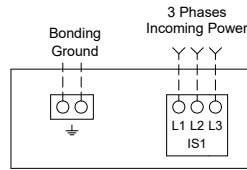

Notes:

- 1 - For proper wire sizing, refer to NFPA70 and NEC (USA) or CEC (Canada) or local code.
- 2 - Controller suitable for service entrance in USA.
- 3 - For more accurate motor connections refer to motor manufacturer or motor nameplate.
- 4 - Controller is phase sensitive. Incoming lines must be connected in ABC sequence.

COPPER CONDUCTORS for Isolating Switch (IS1).
Field Wiring According to Bending Space (AWG or MCM). Terminals L1 - L2 - L3

Bending Space	5" (127 mm)							8" (203 mm)		
	HP	5	7.5	10	15	20	25	30	40	50
208	1x (10 to 1/0)	1x (8 to 1/0)	1x (8 to 1/0)	1x (6 to 1/0)	1x (4 to 1/0)	1x (3 to 1/0)	1x (2 to 1/0)	1x (1/0 to 250)	1x (3/0 to 250)	1x (4/0 to 250)
220 to 240	1x (10 to 1/0)	1x (10 to 1/0)	1x (8 to 1/0)	1x (6 to 1/0)	1x (4 to 1/0)	1x (4 to 1/0)	1x (3 to 1/0)	1x (1 to 250)	1x (2/0 to 250)	1x (3/0 to 250)
380 to 416	1x (10 to 1/0)	1x (10 to 1/0)	1x (10 to 1/0)	1x (8 to 1/0)	1x (8 to 1/0)	1x (6 to 1/0)	1x (6 to 1/0)	1x (4 to 1/0)	1x (3 to 1/0)	1x (3 to 1/0)
440 to 480	1x (10 to 1/0)	1x (10 to 1/0)	1x (10 to 1/0)	1x (10 to 1/0)	1x (8 to 1/0)	1x (8 to 1/0)	1x (6 to 1/0)	1x (6 to 1/0)	1x (4 to 1/0)	1x (3 to 1/0)
600	1x (10 to 1/0)	1x (10 to 1/0)	1x (10 to 1/0)	1x (10 to 1/0)	1x (10 to 1/0)	1x (8 to 1/0)	1x (8 to 1/0)	1x (6 to 1/0)	1x (6 to 1/0)	1x (4 to 1/0)

Bending Space	12" (305 mm)				16" (406 mm)							
	HP	75	100	125	150	200	250	300	350	400	450	500
208	1x (300 to 500)	1x (500)	2x (4/0 to 500)	2x (250 to 500)	2x (400 to 600)	-----	-----	-----	-----	-----	-----	-----
220 to 240	1x (250 to 500)	1x (350 to 500)	2x (3/0 to 500)	2x (4/0 to 500)	2x (350 to 500)	2x (500 to 600)	-----	-----	-----	-----	-----	-----
380 to 416	1x (1/0 to 250)	1x (3/0 to 250)	1x (250)	1x (300 to 500)	2x (3/0 to 250)	2x (4/0 to 500)	2x (300 to 500)	2x (400 to 600) 2x (400 to 500)	2x (500 to 600)	2x (600)	-----	-----
440 to 480	1x (1 to 250)	1x (2/0 to 250)	1x (3/0 to 250)	1x (4/0 to 250)	1x (350 to 500)	2x (3/0 to 250)	2x (4/0 to 500)	2x (300 to 500)	2x (350 to 500)	2x (400 to 600)	2x (500 to 600)	-----
600	1x (3 to 1/0)	1x (1 to 250)	1x (2/0 to 250)	1x (3/0 to 250)	1x (250 to 500)	1x (350 to 500)	2x (3/0 to 250)	2x (4/0 to 500)	2x (250 to 500)	2x (300 to 500)	2x (350 to 500)	-----
Bending Space	5" (127 mm)	8" (203 mm)			12" (305 mm)							

ALUMINUM CONDUCTORS for Isolating Switch (IS1).
Field Wiring According to Bending Space (AWG or MCM). Terminals L1 - L2 - L3

Bending Space	5" (127 mm)							8" (203 mm)		10" (254 mm)
	HP	5	7.5	10	15	20	25	30	40	50
208	1x (10 to 1/0)	1x (6 to 1/0)	1x (6 to 1/0)	1x (4 to 1/0)	1x (3 to 1/0)	1x (1 to 1/0)	1x (1/0)	1x (3/0 to 250)	1x (4/0 to 250)	1x (300) ** or 1x (250) 90°C *
220 to 240	1x (10 to 1/0)	1x (8 to 1/0)	1x (6 to 1/0)	1x (4 to 1/0)	1x (3 to 1/0)	1x (2 to 1/0)	1x (1 to 1/0)	1x (2/0 to 250)	1x (4/0 to 250)	1x (250)
380 to 416	1x (10 to 1/0)	1x (10 to 1/0)	1x (10 to 1/0)	1x (6 to 1/0)	1x (6 to 1/0)	1x (4 to 1/0)	1x (4 to 1/0)	1x (2 to 1/0)	1x (1 to 1/0)	1x (1/0)
440 to 480	1x (10 to 1/0)	1x (10 to 1/0)	1x (10 to 1/0)	1x (8 to 1/0)	1x (6 to 1/0)	1x (6 to 1/0)	1x (6 to 1/0)	1x (4 to 1/0)	1x (2 to 1/0)	1x (1 to 1/0)
600	1x (10 to 1/0)	1x (10 to 1/0)	1x (10 to 1/0)	1x (10 to 1/0)	1x (8 to 1/0)	1x (6 to 1/0)	1x (6 to 1/0)	1x (4 to 1/0)	1x (4 to 1/0)	1x (2 to 1/0)

Bending Space	12" (305 mm)				16" (406 mm)							
	HP	75	100	125	150	200	250	300	350	400	450	500
208	1x (400 to 500)	1x(500) 90°C or 2x(4/0 to 250) **	2x (300 to 500)	2x (350 to 500)	2x (600)	-----	-----	-----	-----	-----	-----	-----
220 to 240	1x (350 to 500)	1x (500)	2x (250 to 500)	2x (300 to 500)	2x (500)	2x (600) 90°C *	-----	-----	-----	-----	-----	-----
380 to 416	1x (3/0 to 250)	1x (250)	1x (350) ** N/A **	1x (400 to 500)	2x (4/0 to 250)	2x (300 to 500)	2x (400 to 500)	2x (500 to 600) 2x (500)	2x (600) 90°C *	2x (600) 90°C *	-----	-----
440 to 480	1x (1/0 to 250)	1x (3/0 to 250)	1x (250)	1x (300) ** or 1x (250) 90°C *	1x (500)	2x (250)	2x (300 to 500)	2x (400 to 500)	2x (500)	2x (600)	2x (600) 90°C *	-----
600	1x (1 to 1/0)	1x (2/0 to 250)	1x (3/0 to 250)	1x (4/0 to 250)	1x (350 to 500)	1x (500)	2x (4/0 to 250)	2x (300 to 500)	2x (350 to 500)	2x (400 to 500)	2x (500)	-----
Bending Space	5" (127 mm)	8" (203 mm)			12" (305 mm)							

* For standard enclosure, use 90°C aluminium wire. Consult Factory for Use of Conductors Rated Lower than 90°C.

** Consult Factory

Drawing for information only.
Manufacturer reserves the right to modify this drawing without notice.
Contact manufacturer for "As Built" drawing.



REV.	DESCRIPTION	DD/MM/YY	Drawing number
2	Revised logo	18/06/18	GPX-TD602 1/2 /E
1	General Revision (added AL coverage)	10/07/17	
0	First issue	16/03/17	

Electric Fire Pump Controller

Model: GPX

Terminal Diagram and Sizing For GPP, GPY & GPW

Built to the latest edition of the NFPA 20 standard

Motor Terminals

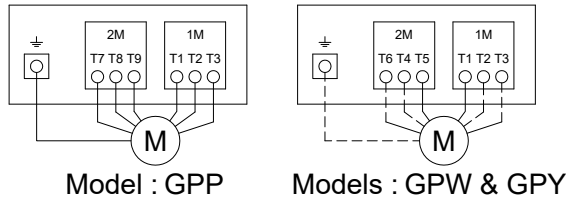

Notes:

- 1 - For proper wire sizing, refer to NFPA70 and NEC (USA) or CEC (Canada) or local code.
- 2 - Controller suitable for service entrance in USA.
- 3 - For more accurate motor connections refer to motor manufacturer or motor nameplate.
- 4 - Controller is phase sensitive. Incoming lines must be connected in ABC sequence.

COPPER CONDUCTORS for Motor Connection (1M-2M).

Field Wiring According to Bending Space (AWG or MCM). Terminals T1-T2-T3-T4-T5-T6-T7-T8-T9

HP Voltage	5	7.5	10	15	20	25	30	40	50	60
208	1x (14 to 10)	1x (12 to 10)	1x (10)	1x (8 to 2)	1x (8 to 2)	1x (6 to 2)	1x (6 to 1/0)	1x (4 to 2/0)	1x (2 to 3/0)	1x (1 to 2/0)
220 to 240	1x (14 to 10)	1x (12 to 10)	1x (10)	1x (8 to 2)	1x (8 to 2)	1x (6 to 2)	1x (6 to 1/0)	1x (4 to 2/0)	1x (3 to 2/0)	1x (2 to 2/0)
380 to 416	1x (14 to 10)	1x (14 to 10)	1x (14 to 10)	1x (12 to 10)	1x (10)	1x (10)	1x (8 to 2)	1x (6 to 2)	1x (6 to 2)	1x (4 to 1/0)
440 to 480	1x (14 to 10)	1x (14 to 10)	1x (14 to 10)	1x (12 to 10)	1x (12 to 10)	1x (10)	1x (10 to 2)	1x (8 to 2)	1x (6 to 2)	1x (6 to 2)
600	1x (14 to 10)	1x (14 to 10)	1x (14 to 10)	1x (14 to 10)	1x (12 to 10)	1x (12 to 10)	1x (10)	1x (10 to 2)	1x (8 to 2)	1x (8 to 2)

HP Voltage	75	100	125	150	200	250	300	350	400	450	500
208	1x (2/0 to 3/0)	1x (3/0 to 300)	1x (250 to 300)	2x (1/0 to 300)	2x (3/0 to 350)	-----	-----	-----	-----	-----	-----
220 to 240	1x (1/0 to 2/0)	1x (3/0)	1x (4/0 to 300)	1x (300)	2x (2/0 to 300)	2x (4/0 to 350)	-----	-----	-----	-----	-----
380 to 416	1x (4 to 2/0)	1x (2 to 2/0)	1x (1/0 to 2/0)	1x (2/0 to 3/0)	1x (4/0 to 300)	1x (300)	2x (2/0 to 300)	2x (3/0 to 300)	2x (4/0 to 350)	2x (4/0 to 350)	-----
440 to 480	1x (4 to 2/0)	1x (3 to 2/0)	1x (2 to 2/0)	1x (1/0 to 3/0)	1x (2/0 to 3/0)	1x (4/0 to 300)	1x (300)	2x (1/0 to 300)	2x (2/0 to 300)	2x (3/0 to 350)	2x (4/0 to 350)
600	1x (6 to 2)	1x (4 to 2/0)	1x (3 to 2/0)	1x (2 to 3/0)	1x (1/0 to 3/0)	1x (2/0 to 3/0)	1x (4/0 to 300)	1x (250 to 300)	1x (300)	2x (1/0 to 300)	2x (2/0 to 300)

ALUMINUM CONDUCTORS for Contactor (1M-2M).

Field Wiring According to Bending Space (AWG or MCM). Terminals T1-T2-T3-T4-T5-T6-T7-T8-T9

HP Voltage	5	7.5	10	15	20	25	30	40	50	60
208	1x (12 to 10)	1x (10)	1x (10)	1x (8 to 2)	1x (6 to 2)	1x (4 to 2)	1x (4 to 1/0)	1x (2 to 2/0)	1x (1/0 to 3/0)	1x (2/0)
220 to 240	1x (12 to 10)	1x (10)	1x (10)	1x (8 to 2)	1x (8 to 2)	1x (6 to 2)	1x (4 to 1/0)	1x (2 to 2/0)	1x (1 to 2/0)	1x (1/0 to 2/0)
380 to 416	1x (12 to 10)	1x (12 to 10)	1x (12 to 10)	1x (10)	1x (10)	1x (8 to 2)	1x (8 to 2)	1x (6 to 2)	1x (4 to 2)	1x (3 to 1/0)
440 to 480	1x (12 to 10)	1x (12 to 10)	1x (12 to 10)	1x (12 to 10)	1x (10)	1x (10)	1x (8 to 2)	1x (8 to 2)	1x (6 to 2)	1x (4 to 2)
600	1x (12 to 10)	1x (12 to 10)	1x (12 to 10)	1x (12 to 10)	1x (10)	1x (10)	1x (10)	1x (8 to 2)	1x (8 to 2)	1x (6 to 2)

HP Voltage	75	100	125	150	200	250	300	350	400	450	500
208	1x (3/0)	Consult Factory	1x (300) 90°C *	2x (3/0 to 300)	2x (250 to 350)	-----	-----	-----	-----	-----	-----
220 to 240	1x (2/0) 90°C *	Consult Factory	1x (300)	1x (300) 90°C *	2x (4/0 to 300)	2x (300 to 350)	-----	-----	-----	-----	-----
380 to 416	1x (2 to 2/0)	1x (1/0 to 2/0)	1x (1/0 to 2/0)	1x (3/0) 90°C *	1x (300)	1x (300) 90°C *	2x (4/0 to 300)	2x (250 to 300)	2x (300 to 350)	2x (300 to 350)	-----
440 to 480	1x (3 to 2/0)	1x (2 to 2/0)	1x (2/0) 90°C *	1x (2/0 to 3/0)	1x (3/0) 90°C *	1x (300)	1x (300) 90°C *	2x (3/0 to 300)	2x (4/0 to 300)	2x (250 to 350)	2x (300 to 350)
600	1x (4 to 2)	1x (3 to 2/0)	1x (2 to 2/0)	1x (1/0 to 3/0)	1x (3/0)	1x (3/0) 90°C *	1x (300)	1x (300) 90°C *	Consult Factory	2x (3/0 to 300)	2x (4/0 to 300)

*For standard enclosure, use 90°C aluminium wire. Consult Factory for Use of Conductors Rated Lower than 90°C.

Drawing for information only.
Manufacturer reserves the right to modify this drawing without notice.
Contact manufacturer for "As Built" drawing.



REV.	DESCRIPTION	DD/MM/YY	Drawing number
2	Revised logo	18/06/18	GPX-TD602 2/2 /E
1	General Revision (added AL coverage)	10/07/17	
0	First issue	16/03/17	

JOCKEY PUMP DATA

Fire Fighting Solutions Provider

ص.ب: ٧٤٥٨٢ . دبي الامارات العربية المتحدة تيلفون : ٣٤٧٧٠٧٣ / ٣٤٧٢٤٢٦ +٩٧١ ٤ ٣٤٧٢٣٦٣ فاكس : +٩٧١ ٤ ٣٤٧٢٣٦٣

P.O.Box 74582 Dubai UAE. Tel: +971 4 3472426 / 3472073 Fax: +971 4 3472363 E: info@hbrintal-fire.com www.hbrintal-fire.com



Applications

Application	RVA	RV
Water supply		
Filtration and transfer at waterworks	●	●
Distribution from waterworks	●	●
Pressure boosting in mains	●	●
Pressure boosting in high-rise buildings, hotels, etc.	●	●
Pressure boosting for industrial water supply	●	●
Industry		
Pressure boosting		
Process water systems	●	●
Washing and cleaning systems	●	●
Vehicle washing tunnels	●	●
Fire fighting systems	●	●
Liquid transfer		
Cooling and air-conditioning systems (refrigerants)	●	●
Boiler feed and condensate systems	●	●
Machine tools (cooling lubricants)	●	●
Aquafarming	●	●
Transfer		
Oil and alcohol	●	●
Glycol and coolants	●	●
Water treatment		
Ultra-filtration systems	●	○
Reverse osmosis systems	●	○
Softening, ionising, demineralizing systems	●	○
Distillation systems	●	○
Separators	●	○
Swimming baths	●	●
Irrigation		
Field irrigation (flooding)	●	●
Sprinkler irrigation	●	●
Drip-feed irrigation	●	●

- Recommended pump model
- Option pump model

Product introduction

Vertical Multistage Centrifugal Pump

Product range

Range	RV1 RVA1	RV2 RVA2	RV3 RVA3	RV4 RVA4	RV5 RVA5	RV10 RVA10	RV15 RVA15	RV20 RVA20	RV32 RVA32	RV45 RVA45	RV64 RVA64	RV90 RVA90
Nominal rated []	1	2	3	4	5	10	15	20	32	45	64	90
Temperature range [°C]	-20~+104											
Temperature on range [°C]	-40~+180								-40~+180			
Max Efficiency []	44	45	56	58	65	66	68	69	77	78	80	81
RVpump												
Flow range []	0.7-2.4	1-3.2	1.2-4.5	2-4.8	2.5-8	5-13	9-24	10-29	14-40	20-56	30-85	40-120
Max Pressure []	22	25	24	25	24	22	23	25	28	26	20	20
High Pressure on request []	47	47	47	47	47	47	47	47	39	40	39	39
Motor power []	0.37-2.2	0.37-3	0.37-3	0.37-4	0.37-5.5	0.37-7.5	1.1-15	1.1-18.5	1.5-30	3-45	4-45	5.5-45
Material type												
RV cast iron, S.S EN1.4301/AISI 304	●	●	●	●	●	●	●	●	●	●	●	●
RVA S.S EN1.4301/AISI 304	●	●	●	●	●	●	●	●	●	●	●	●
RVN S.S EN1.4401/AISI 316	●	●	●	●	●	●	●	●	●	●	●	●
RVpump pipe connection												
Flange	DN25 DN32	DN25 DN32	DN25 DN32	DN25 DN32	DN25 DN32	DN40	DN50	DN50	DN65	DN80	DN100	DN100
Flange on request	-	-	-	-	-	DN50	DN65	DN65	DN80	DN100	DN125	DN125
RVA/RV pump pipe connection												
column pipe thread★	G1 G1¼	G1 G1¼	G1 G1¼	G1 G1¼	G1 G1¼	G1½ G2	G2½	G2½	-	-	-	-
column pipe thread on request★	G1½	G1½	G1½	G1½	G1½	-	G2	G2	-	-	-	-
Flange	DN25 DN32	DN25 DN32	DN25 DN32	DN25 DN32	DN25 DN32	DN40	DN50	DN50	DN65	DN80	DN100	DN100
Flange on request	-	-	-	-	-	DN50	DN65	DN65	DN80	DN100	DN125	DN125
Cutting ferrule joint [] ★	G1¼ DN32	G1¼ DN32	G1¼ DN32	G1¼ DN32	G1¼ DN32	G2 DN50	G2 DN50	G2 DN50	-	-	-	-

★NPT thread are on request

Pump

RVA and RV are non-self priming vertical multistage centrifugal pump, the pumps are available with standard motor, the inlet and outlet are located at the pump bottom at the same plane (inline type). All pumps are equipped with a maintenance-free mechanical seal set of the cartridge type.

Fig.1 RVA

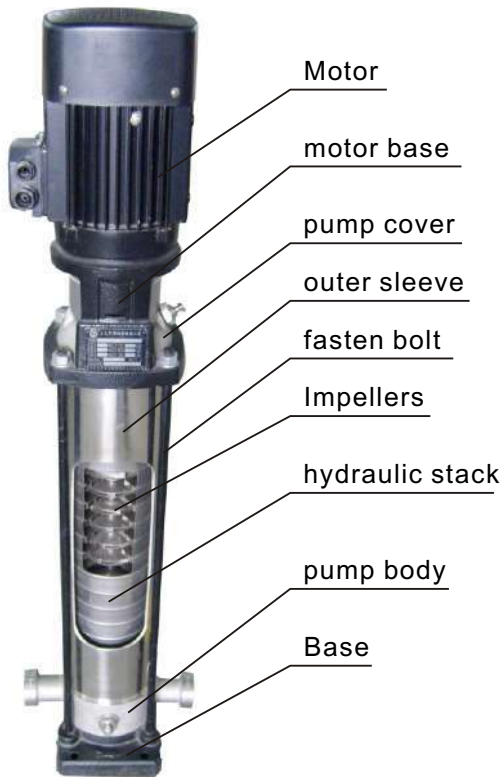

Motor

RVA and RV are fitted with a totally enclosed, fan-cooled, 2-pole, three-phase standard motor. From 0.37kW to 2.2kW, are also available with single-phase motor. (1*220-230V/240V).

Motor Protection

Single-phase motor have a built-in thermal overload switch. Three-phase motors must be connected to a motor protective circuit breaker according to local regulations.

Ambient temperature

Ambient temperature: maximum +40°C, if the ambient temperature exceeds +40°C, or the pump is installed at an altitude exceeding 1000 meters, the motor must not be fully loaded due to the risk of overheating. Overheating may result from excessive ambient temperatures or the low density and consequently low cooling effect of the air. In such cases, it may be necessary to use a motor with a higher rated output.

Terminal box positions

As standard the terminal box is mounted on the suction side of the pump, meanwhile, 0°, 90°, 180°, 270° could be adjusted according to the following proceeding:

1. If necessary, disassembling the protective cover of the shaft connector, but did not disassembling the shaft connector.
2. Disassembling the motor fixation screws.
3. Turn the motor to the required direction.
4. Fasten the motor screws.
5. Install the shaft connector's protective cover.

The voltage and frequency are marked on the label, the correct power should be confirm with the label before usage.

To ensure the electric connection is conformity to the drawing marked on the label inside the terminal box.

Fig2. Terminal box positions

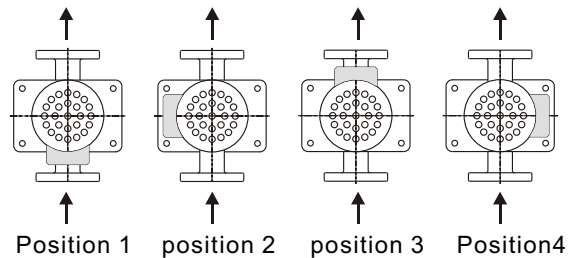

Viscosity

The pumping of liquids with densities or kinematic viscosities higher than those of water will cause a considerable pressure drop, a drop in the hydraulic performance and a rise in the power consumption.

In such situations the pump should be fitted with a larger motor, if in doubt.

Fig.3 Relationship between motor output (P2) and temperature

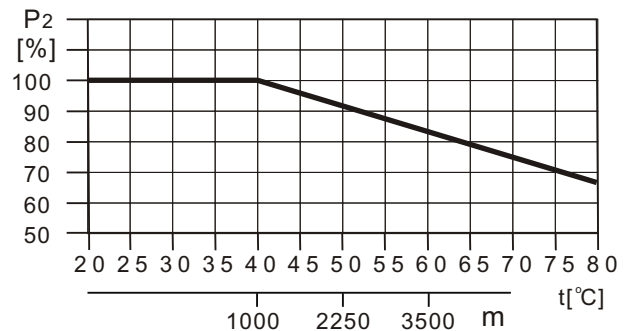

Example:

From the Fig.3, the pump is installed at an altitude exceeding altitude 3500 meters, P_2 will decrease to 88%, if the ambient temperature is up to 70°C, P_2 will decrease to 78%.

RV1,2,3,4,5
Sectional drawing

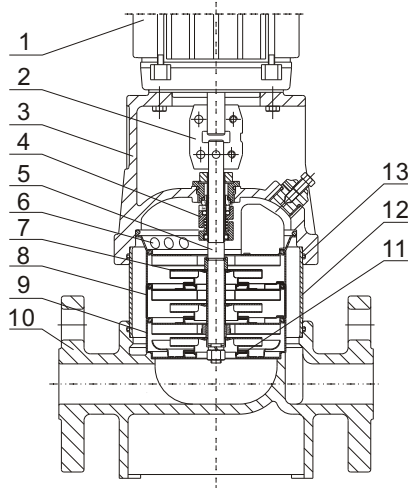

RVA1,2,3,4,5
Sectional drawing

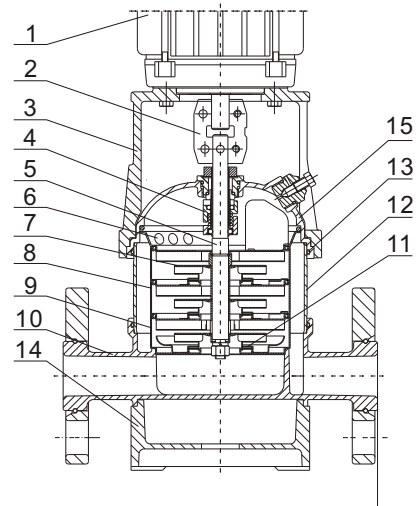

Material RV

No.	Description	Material	EN/DIN	AISI/ASTM
1	Motor			
2	Shaft connector			
3	Pump head	Castiron	EN-JL1030	ASTM25B
4	Mechanical seal			
5	Shaft	S.S		AISI420
6	Outlet	S.S	1.4301	AISI304
7	Impeller	S.S	1.4301	AISI304
8	Hydraulic stack	S.S	1.4301	AISI304
9	Inlet	S.S	1.4301	AISI304
10	Pump body	Castiron	EN-JL1030	ASTM25B
11	Neck ring	PTFE		
12	Outer sleeve	S.S	1.4301	AISI304
13	O-ring	EPDM/FKM		

Material RVA

No.	Description	Material	EN/DIN	AISI/ASTM
1	Motor			
2	Shaft connector			
3	Pump head	Castiron	EN-JL1030	ASTM25B
4	Mechanical seal			
5	Shaft	S.S	1.4057	AISI431
6	Outlet	S.S	1.4301	AISI304
7	Impeller	S.S	1.4301	AISI304
8	Hydraulic stack	S.S	1.4301	AISI304
9	Inlet	S.S	1.4301	AISI304
10	Pump body	S.S	1.4301	AISI304
11	Neck ring	PTFE		
12	Outer sleeve	S.S	1.4301	AISI304
13	O-ring	EDM/FKM		
14	Bottom base	Castiron	EN-JL1030	ASTM25B
15	Pump cover	S.S	1.4301	AISI304

Minimum inlet pressure-NPSH

Calculation of the inlet pressure "H" is recommended in these situations :

- the liquid temperature is high.
 - the flow is significantly higher than the rated flow.
 - water is drawn from depths.
 - water is drawn through long pipes.
- inlet conditions are poor. to avoid cavitation, make sure that there is a minimum pressure on the suction side of the pump.

The maximum suction lift "H" in metres head can be calculated as follows:

$$H = P_b * 10.2 - NPSH - H_f - H_v - H_s$$

P_b = Barometric pressure in bar.
(Barometric pressure can be set to 1 bar).
in closed systems, P_b indicates the system pressure in bar.

NPSH = Net positive suction Head in metres head.
(To be read from the NPSH curve at the highest flow the pump will be delivering).

H_f = Friction loss in suction pipe (unit: m).
(At the highest flow the pump will be delivering.)

H_v = Vapour pressure (unit: m).
(To be read from the vapour pressure scale).

H_s = safety margin = minimum 0.5 metres head.

If the "H" calculated is positive, the pump can operate at a suction lift of maximum "H" metres head. If the "H" calculated is negative, an inlet pressure of minimum "H" metres head is required.

Example:

$P_b = 1 \text{ bar}$
 pump model: RVA10, 50Hz
 flow: $10 \text{ m}^3/\text{h}$
 NPSH (P36 reference): 2.1 metres head.
 liquid temperature: $+50^\circ\text{C}$
 H_v (reference picture 4): 1.3 metres head.
 $H = P_b * 10.2 - NPSH - H_f - H_v - H_s$
 $H = 1 * 10.2 - 2.1 - 3.0 - 1.3 - 0.5 = 3.3 \text{ (metres)}$

It means the pump can operate at a suction lift of maximum 3.3 metres head.

exchanged meter head to bar:

$$1 \text{ metre head} = 1 * 0.0981 = 0.0981 \text{ bar}$$

exchanged metre head to kpa:

$$1 \text{ metre head} = 1 * 9.81 = 9.81 \text{ kpa.}$$

Fig.13 Minimum inlet pressure-NPSH

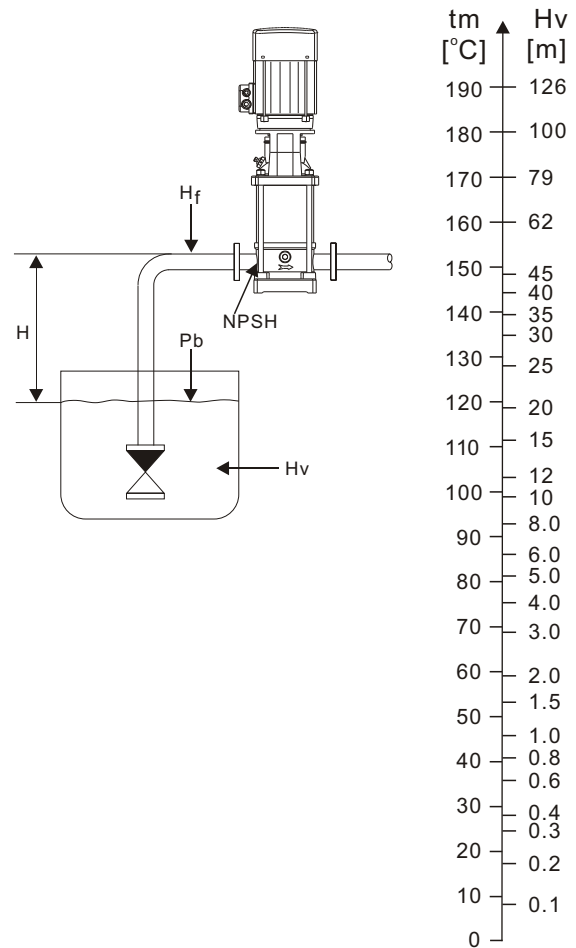

Multistage Centrifugal Pumps - 60 Hz

FV & FH - SERIES

Zirantec



www.zirantec.com



FABBRICA ITALIANA POMPE SOMMERSIBILI S.r.l

Zirantec



ZIRANTEC products are
manufactured by well
qualified and experienced
Italian Pump Engineers
in state of the art
manufacturing facilities
in Italy

CERTIFICATION



ZIRANTEC Pumps & Motors are from the house of **Fabbrica Italiana Pompe Sommergibili S.r.l.** a four decades old Italian company of high repute, offering complete waste water solutions around the world. Its current product portfolio includes world class Waste Water Pumps of various types, Multistage Centrifugal Pressure Booster Pumps, Borehole Submersible Pumps & Motors, End Suction Centrifugal Pumps, Industrial Pumps for various applications.

Founded as early as 1978 in Rozzano, South of Milan, Italy by Mr.Orfeo Agostini, the company has witnessed steady growth and market expansion continuously ever since. In these four decades of existence, the company has carved a niche for itself in the waste water and sewage pump market in Italy and other countries. Its products are employed in Municipal, Domestic and Industrial applications. The Company is well known for the unique and robust designs of its products and their workmanship. Due to its superior quality ZIRANTEC products are also exported to many European, African and Asian countries.

ZIRANTEC's products are conceived, designed and manufactured by well qualified and experienced Italian Pump Engineers in state of the art manufacturing facilities in Italy. These manufacturing plants are accredited with UNI EN ISO 9001:2008 Certification.

Over the years, the company has metamorphosed and ventured into manufacturing of high quality water pumps, for domestic, agricultural and industrial applications. In the due process, Fabbrica Italiana Pompe Sommergibili S.r.l. has shed its image of an exclusive sewage and waste water pumps manufacturer to a complete pump production company with an ability to manufacture diverse kinds of pumps for different applications.

JOCKEY PUMP CONTROLLER DATA

Fire Fighting Solutions Provider

ص.ب: ٧٤٥٨٢ . دبي الامارات العربية المتحدة تيلفون : ٣٤٧٧٠٧٣ / ٣٤٧٢٤٢٦ +٩٧١ ٤ ٣٤٧٢٣٦٣ فاكس : +٩٧١ ٤ ٣٤٧٢٣٦٣

P.O. Box 74582 Dubai UAE. Tel: +971 4 3472426 / 3477073 Fax: +971 4 3472363 E-mail: info@hrital-fire.com www.hrital-fire.com



TORNATECH

Project: _____

Customer: _____

Engineer: _____

Pump Manufacturer: _____

Technical Data Submittal Document

Model JP3

Across the Line Start
Jockey Pump Controller



Contents:

Data Sheets

Dimensional Data

Wiring Schematics

Field Connections

Note: The drawings included in this package are for controllers covered under our standard offering. Actual AS BUILT drawings may differ from what is shown in this package.



N.Y.C.
APPROVED



OPTIONAL



November 2020

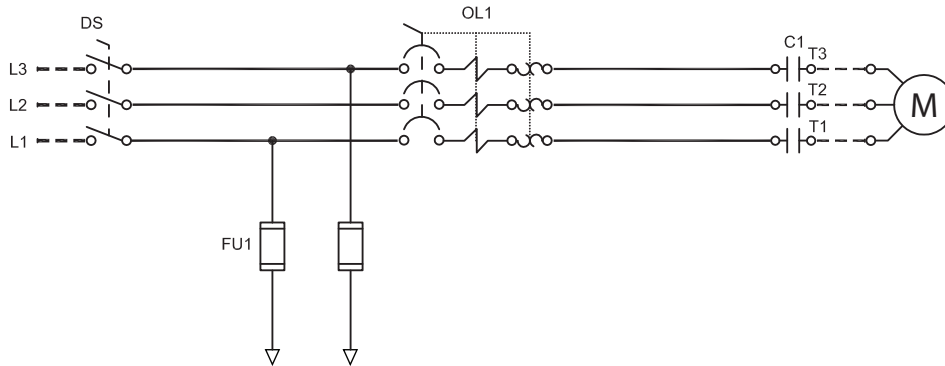

N.Y.C.
APPROVED



OPTIONAL



Listing	Underwriters Laboratory (UL)	UL508A - Industrial Pump Controllers	
	New York City	Accepted for use in the City of New York by the Department of Buildings	
	Seismic Certification	See page 4 for details	
	Optional		
	<input type="checkbox"/> CE Mark	Various EN, IEC & CEE directives and standards	
Enclosure	Protection Rating		
	<input type="checkbox"/> Standard: NEMA 2		
	Optional		
	<input type="checkbox"/> NEMA 12	<input type="checkbox"/> NEMA 4X-304 sst painted	<input type="checkbox"/> IP54
	<input type="checkbox"/> NEMA 3	<input type="checkbox"/> NEMA 4X-304 sst brushed finish	<input type="checkbox"/> IP55
<input type="checkbox"/> NEMA 3R	<input type="checkbox"/> NEMA 4X-316 sst painted	<input type="checkbox"/> IP65	
<input type="checkbox"/> NEMA 4	<input type="checkbox"/> NEMA 4X-316 sst brushed finish	<input type="checkbox"/> IP66	
	Accessories		Paint Specifications
	• Wall mounting lugs (x4)		• Red RAL3002 • Powder coating • Glossy textured finish



Fuseless Motor Starter	<ul style="list-style-type: none"> • Main disconnect – padlockable – rotary type handle – door interlocked • Thermo-magnetic motor protector • Contactor 		
Control Circuit	<ul style="list-style-type: none"> • 24V.AC 		
iPD+ Operator Interface	<ul style="list-style-type: none"> • Solid state controls • All adjustments on door front • Navigation pushbuttons 		
Pressure Sensing	<ul style="list-style-type: none"> • Pressure transducer for fresh water application 316 stainless steel construction • Rated for 0-600psi working pressure • Pressure sensing line connection 1/2" brass Male NPT 		
Visual Indications	<ul style="list-style-type: none"> • Manual motor start/run LED • Automatic motor start/run LED • Motor overload • Pressure reading <ul style="list-style-type: none"> • Start pressure • Stop pressure • System pressure • System pressure diagnostic LED's <ul style="list-style-type: none"> • Green: system pressure at or above stop pressure • Yellow: system pressure between start and stop pressure • Red: system pressure at or below start pressure • AUTO mode • OFF mode 		
Timers	<ul style="list-style-type: none"> • Minimum run timer (off delay) • Delay start timer (on delay) • Visual countdown 		
Counters	<ul style="list-style-type: none"> • Pump start counter • Elapsed timer meter (hours / non-resettable) 		
Operators	<ul style="list-style-type: none"> • OFF-AUTO pushbutton • Start and Stop pushbutton 		
Operation	Automatic Start	Start on pressure drop	
	Manual Start	Start pushbutton	
	Stopping	Stop pushbutton	
	Timers	Field adjustable & visual countdown	<ul style="list-style-type: none"> • Minimum run timer (off delay) • Delay start timer (on delay)



Seismic Certification	Seismic Certification Company	TRU Compliance, LLC A Tobalski Watkins Affiliate					TWEI Project No.: 15014				
	Mounting details	Rigid wall mounting									
	Seismic Information	Building Code	Test Criteria	Seismic Parameters	S_{DS}	z/h	I_P	A_{FLX-H}	A_{RIG-H}	A_{FLX-V}	A_{RIG-V}
	IBC 2015, CBC 2016	ICC-ES AC156	ASCE 7-10 Chapter 13	2.0	1.0	1.5	3.20	2.40	1.33	0.53	
				3.2	0.0	1.5	3.20	1.28	2.13	0.85	

RRS for Nonstructural Components Testing

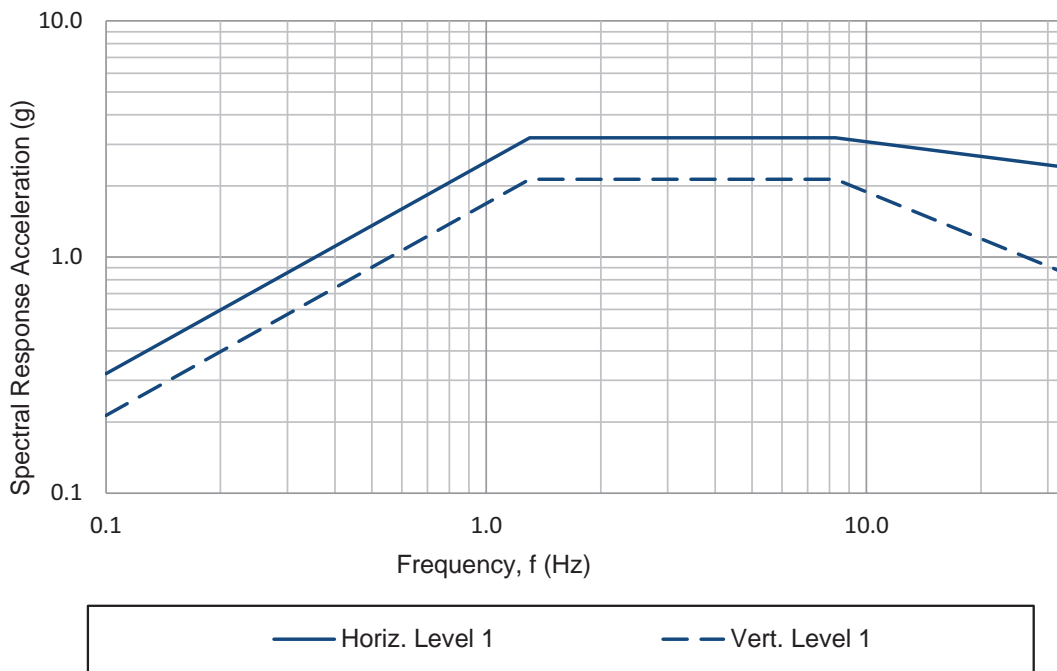

Notes:

- Components are tested in accordance with ICC-ES AC156, IBC 2015 & CBC 2016.
- OSHPD Special Seismic Certification Preapproval (OSP)



<input type="checkbox"/> A4	Elapsed time meter (time totalizer)
<input type="checkbox"/> A5	Motor run alarm contact
<input type="checkbox"/> A6	Loss of power alarm contact
<input type="checkbox"/> A7	Overload or short circuit alarm contact
<input type="checkbox"/> D11D	Pressure transducer 0-600psi with ½" MNPT 316 stainless steel bushing
<input type="checkbox"/> D14	Export packing for 1 controller
<input type="checkbox"/> D13A	Externally mounted wetted parts
<input type="checkbox"/> D14	Export packing for 1 controller
<input type="checkbox"/> D18	Audible alarm
<input type="checkbox"/> D19	Anti-condensation heater and thermostat
<input type="checkbox"/> D20	Anti-condensation heater and humidistat
<input type="checkbox"/> D21	Tropicalization
<input type="checkbox"/> D22	Phase reversal / failure pilot light and alarm contact
<input type="checkbox"/> D23	Controller power healthy pilot light and alarm contact
<input type="checkbox"/> D24	Pump failure via current sensing relay with pilot light and dry alarm contact
<input type="checkbox"/> D25	Low zone pump control function
<input type="checkbox"/> D26	Mid zone pump control function
<input type="checkbox"/> D27	High zone pump control function
<input type="checkbox"/> D28	Selector switch in auto alarm contacts
<input type="checkbox"/> D29	Selector switch in off alarm contacts
<input type="checkbox"/> D30	Motor heater circuit
<input type="checkbox"/> D32	Service entrance rated - 100kA short circuit withstand rating: • 120V/1ph (0.5hp max.) • 240V/1ph (1hp max.) • 200V-208V - 60hz (2hp max.) • 220V-240V - 60hz (3hp max.) • 380V-416V - 50hz - 60hz (5hp max.) • 440V-480V - 60hz (5hp max.)
<input type="checkbox"/> D33	Service entrance rated - 65kA short circuit withstand rating: • 120V/1ph (0.5hp max.) • 240V/1ph (1hp max.) • 200V-208V - 60hz (3hp-15hp max.) • 220V-240V - 60hz (515hp max.) • 380V-416V - 50hz - 60hz (7.5hp - 40hp max.) • 440V-480V - 60hz (7.5hp-40hp max.)
<input type="checkbox"/> D34	Service entrance rated - 42kA short circuit withstand rating: • 600V - 60hz (7.5hp max.)

<input type="checkbox"/> L01	Other language and English (bilingual)
<input type="checkbox"/> L02	French
<input type="checkbox"/> L03	Spanish
<input type="checkbox"/> L04	German
<input type="checkbox"/> L05	Italian
<input type="checkbox"/> L06	Polish
<input type="checkbox"/> L07	Romanian
<input type="checkbox"/> L08	Hungarian
<input type="checkbox"/> L09	Slovak
<input type="checkbox"/> L10	Croatian
<input type="checkbox"/> L11	Czech
<input type="checkbox"/> L12	Portuguese
<input type="checkbox"/> L13	Dutch
<input type="checkbox"/> L14	Russian
<input type="checkbox"/> L15	Turkish
<input type="checkbox"/> L16	Swedish
<input type="checkbox"/> L17	Bulgarian
<input type="checkbox"/> L18	Thai
<input type="checkbox"/> L19	Indonesian
<input type="checkbox"/> L20	Slovenian
<input type="checkbox"/> L21	Danish
<input type="checkbox"/> L22	Greek
<input type="checkbox"/> L23	Arabic
<input type="checkbox"/> L24	Hebrew
<input type="checkbox"/> L25	Chinese

Note: Options chosen from this page are not electrically represented on the wiring schematics in this submittal package.

iPD+ Operator Interface

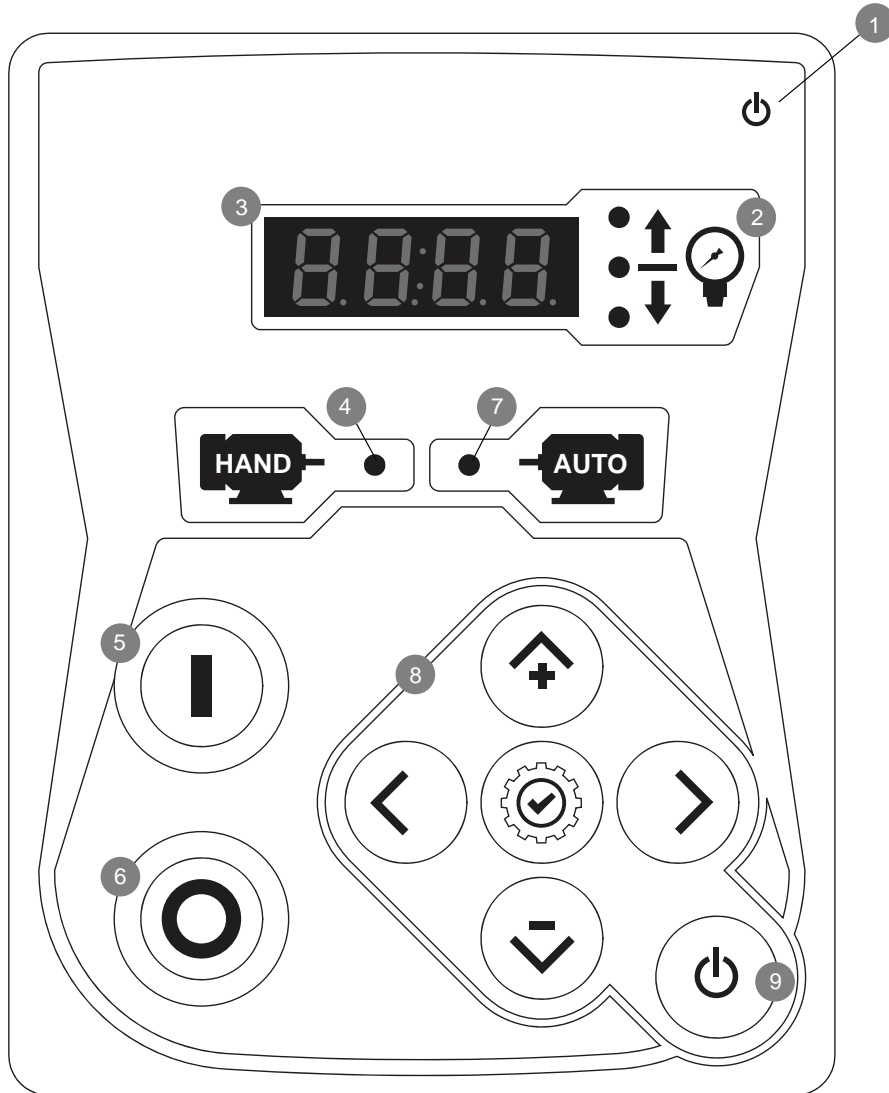

- | | |
|-----------------------|-------------------------|
| 1 - Power on LED | 6 - STOP pushbutton |
| 2 - System status LED | 7 - Auto start LED |
| 3 - Digital display | 8 - Navigation keypad |
| 4 - Hand start LED | 9 - ON - OFF pushbutton |
| 5 - START pushbutton | |

Jockey Pump Controller

Across the Line / 3 Phase

Model:JP3

PER QUOTE DRAWING No.



REV.	DESCRIPTION	DD/MM/YY
7	Revised logo	18/06/18
8	Sensing line connection changed	25/03/25
9	UL logo updated CSA logo removed	14/07/20

Drawing No: JP3-DI500/E

Dimensions

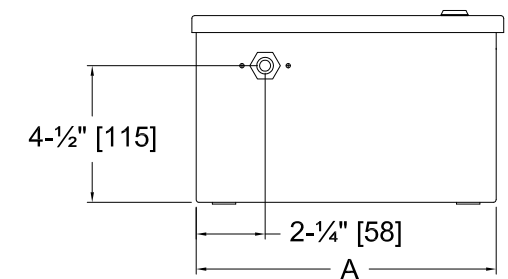
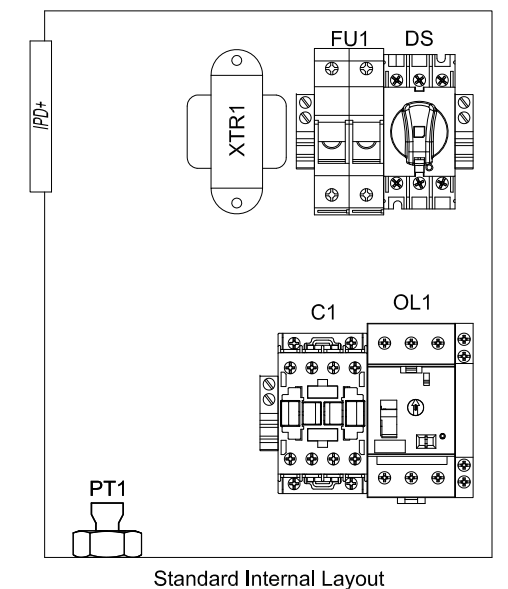
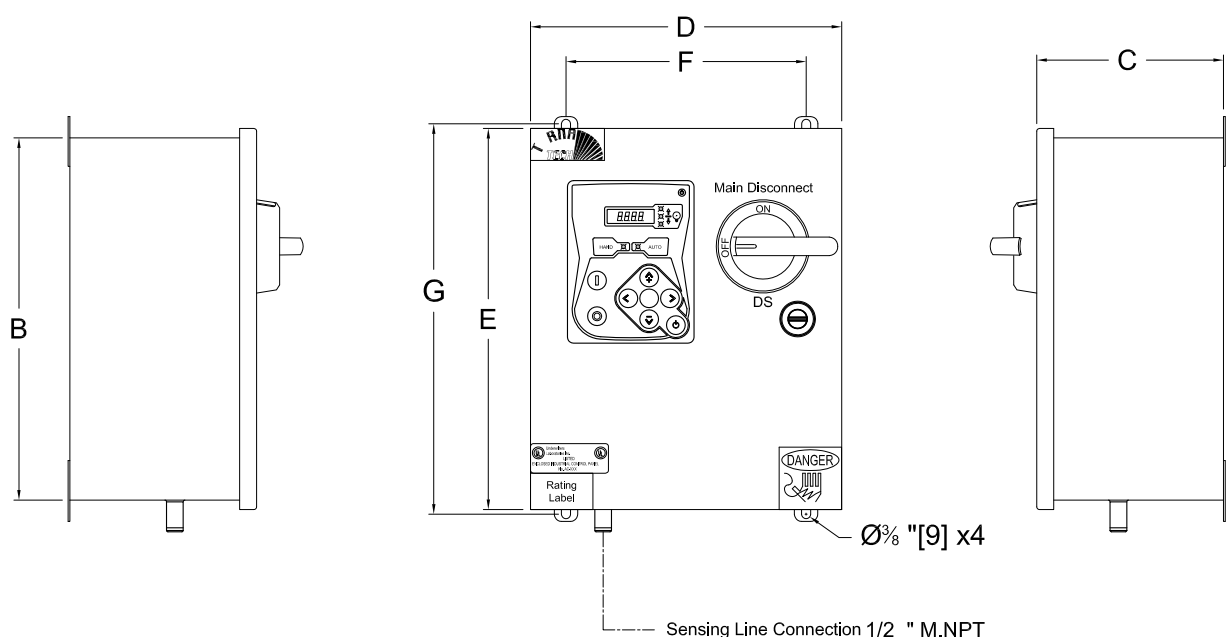

Dimensions*					Enclosure Dimensions A X B X C	Door Dimensions D X E	Anchor Dimensions F X G
Maximum Motor Horsepower							
200-208V	220-240V	380-416V	440-480V	575-600V	10"X12"X6-1/2"	10-3/4"X12-3/4"	8"X12-3/4"
10HP	10HP	15HP	20HP	25HP	16"X16"X7-1/2"	16-1/2"X16-1/2"	14"X16-3/4"
20HP	30HP	40HP	60HP	60HP			

- Notes:
- Standard NEMA: NEMA 2
 - Standard Paint: Textured Red RAL 3002.
 - All Dimensions are in Inches [Millimeters]
 - Use Watertight Conduit and Connector Only.
 - Protect Equipment Against Drilling Chips.
 - Door Swing Equal to Door Width

Drawing for information only.
 Manufacturer reserves the right to modify this drawing without notice.
 Contact manufacturer for "As Built" drawing.
 *Dimensions may change depending on option required. Consult Factory for exact dimensions.

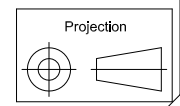

Jockey Pump Controller

Across the Line / 3 Phase

Model:JP3

Wiring schematic

PER QUOTE DRAWING No.



REV.	DESCRIPTION	DD/MM/YY
6	Modified J19 Outputs ID	10/06/16
7	Revised logo	18/06/18
8	UL logo updated CSA logo removed	14/07/20

Drawing No:

JP3-WS500/E

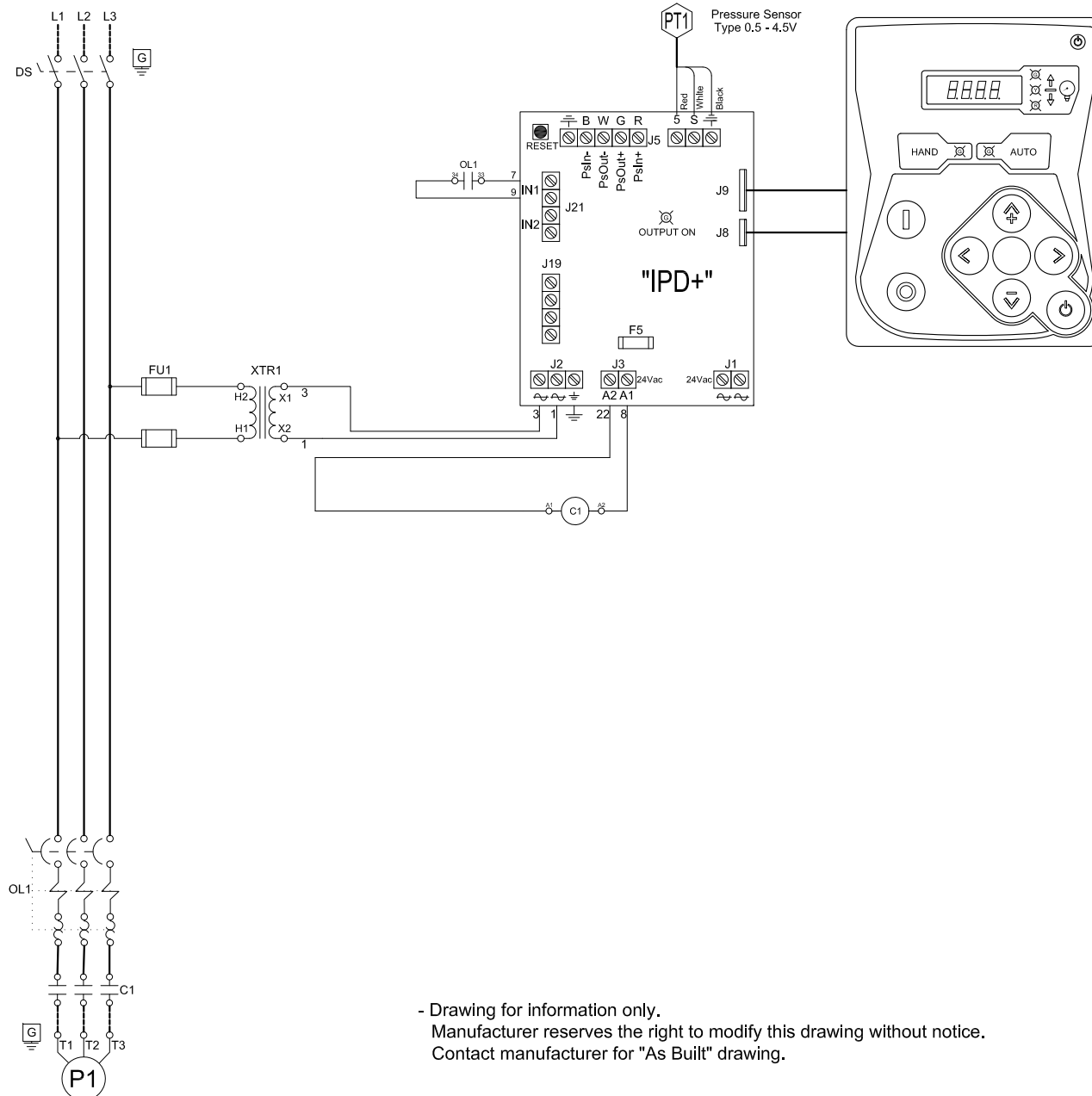

- Drawing for information only.
 Manufacturer reserves the right to modify this drawing without notice.
 Contact manufacturer for "As Built" drawing.

Jockey Pump Controller

Across the Line / 3 Phase

Model:JP3

Line and Motor Terminal Size

PER QUOTE DRAWING No.



REV.	DESCRIPTION	DD/MM/YY
6	Modified J19 Outputs ID	10/06/16
7	Revised logo	18/06/18
8	UL logo updated CSA logo removed	14/07/20

Drawing No:
JP3-TD500/E

Power Connections and Motor Connections

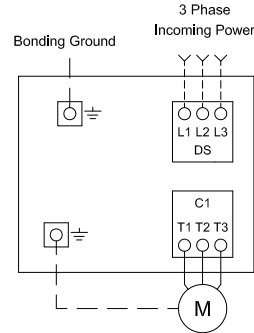

Line Terminals (L1,L2,L3,GND)

Maximum Motor Horsepower					Wire Size Copper Only	Torque	Wire Size Ground Copper Only
200-208V	220-240V	380-416V	440-480V	575-600V			
10HP	10HP	20HP	20HP	25HP	#14 AWG - #6 AWG	2 Nm	#14 AWG - #2 AWG
20HP	30HP	40HP	60HP	60HP	#12 AWG - #1 AWG	6 Nm	#6 AWG - #2 AWG

Motor Terminals (T1,T2,T3,GND)

Maximum Motor Horsepower					Wire Size Copper Only	Torque	Wire Size Ground Copper Only
200-208V	220-240V	380-416V	440-480V	575-600V			
5HP	7.5HP	10HP	15HP	20HP	#14 AWG - #10 AWG	1.8 Nm	#14 AWG - #2 AWG
10HP	10HP	15HP	20HP	25HP	#14 AWG - #6 AWG	2.5 Nm	#12 AWG - #2 AWG
15HP	20HP	30HP	50HP	50HP	#10 AWG - #3 AWG	5 Nm	#12 AWG - #2 AWG
20HP	30HP	40HP	60HP	60HP	#10 AWG - #2 AWG	11.3 Nm	#12 AWG - #2 AWG

ACCESSORIES

Fire Fighting Solutions Provider

ص.ب: ٧٤٥٨٢ . دبي الامارات العربية المتحدة تيلفون : ٣٤٧٧٠٧٣ / ٣٤٧٢٤٢٦ +٩٧١ ٤ ٣٤٧٢٣٦٣ فاكس : +٩٧١ ٤ ٣٤٧٢٣٦٣

P.O. Box 74582 Dubai, UAE. Tel: +971 4 3472426 / 3477073. Fax: +971 4 3472363. E-mail: info@hritel-fire.com, www.hritel-fire.com



Bourdon Tube Pressure Gauges

Black Polycarbonate Case

Copper Alloy Wetted Parts

UL Listed / FM Approved

Sprinkler Gauges • Type 111.10SP

Pressure Gauges

Application

Fluid medium which does not clog connection port or corrode copper alloy. Specifically designed for the fire sprinkler industry.

Sizes

4" (100 mm)

Accuracy

± 3/2/3% of span (ASME B40.1 Grade B)

Ranges

0/80 PSI retard to 250 PSI (Air)

0/300 PSI (Water)

Working Range

Steady: 3/4 of full scale value

Fluctuating: 2/3 of full scale value

Short time: full scale value

Operating Temperature

Ambient: -40°F to 140°F (-40°C to 60°C)

Media: max. 140°F (+60°C)

Temperature Error

Additional error when temperature changes from reference temperature of 68°F (20°C) ±0.4% for every 18°F (10°C) rising or falling. Percentage of span.

Standard Features

Connection

Material: copper alloy

Lower mount (LM)

1/4" NPT limited to wrench flat area

Bourdon Tube

Material: copper alloy

C-type

Movement

Copper alloy

Dial

White aluminum with stop pin. Black and red markings

Pointer

Black aluminum-non-adjustable

Case

Black polycarbonate

Window

Snap-in clear polycarbonate

Approvals

UL Listed (UL-393)

Factory Mutual Approved



Order Options (not all options are UL or FM approved)

Brass threaded or press fit restrictor

Cover ring

Glass window

Black painted steel case

Stainless steel case

Special case colors

Special connections limited to wrench flat area

Nickel plated connection

Custom dial layout

Other pressure scales available:

Bar, kPa, MPa, Kg/cm² and dual scales

DIN standards

APM 111.10SP

(APM 01.01.4)

Dimensions:

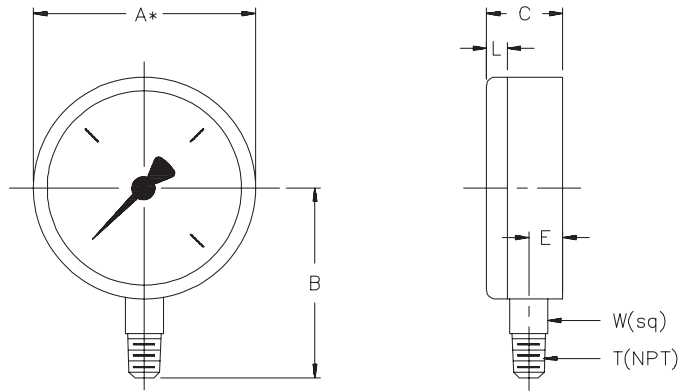

A* NOMINAL SIZE

111.10SP 4" LM	WEIGHT	KEY	A*	B	C	E	L	T	W	
	0.35 lbs.	mm		100	83.5	30	11.5	3.75	--	14
		in		4.0	3.29	1.18	0.45	0.15	1/4	0.55

THE MEASURE OF
Total Performance™

Ordering Information:

State computer part number (if available) / type number / size / range / connection size and location / options required.

Specifications given in this price list represent the state of engineering at the time of printing. Modifications may take place and the specified materials may change without prior notice

05/01



WIKAI Instrument Corporation

1000 Wiegand Boulevard

Lawrenceville, Georgia 30043-5868

Tel: 770-513-8200 Fax: 770-338-5118

<http://www.wika.com> e-mail: info@wika.com



Description & Features:

- Specially designed for fire sprinkler systems
- Suitable for air and water media
- Corrosion resistant case
- Dual scales (psi/kpa, psi/bar, psi/kg/cm²) and single scale (psi) pressure ratings
- Approved by Factory Mutual (FM) and listed by Underwriter Laboratory (UL-393), USA and Canada
- Internal pointer over-travel stop
- ASME B40.100 compliant
- CRN registered
- 5 year warranty

Applications:

- Ideally suited for fire sprinkler systems and fire fighting equipment
- Suitable for non-clogging and non-corrosive media

Specifications

Dial	3.5" (90mm), white aluminum with black and red markings
Case	Black plastic
Lens	Polycarbonate, threaded
Socket	Brass
Connection	1/4" NPT standard, bottom
Bourdon Tube	Phosphor bronze
Movement	Brass
Pointer	Aluminum, black
Welding	Silver Alloy
Working Pressure	Maximum 75% of full scale value
Ambient/Process Temperature	-40°F to 150°F (-40°C to 65°C)
Accuracy	±3-2-3% ASME Grade B
Enclosure Rating	IP52
Warning	 WARNING: This product can expose you to chemicals including lead, which is known to the State of California to cause cancer and birth defects or other reproductive harm. For more information go to www.P65Warnings.ca.gov .

Order Codes (products in bold are normally stock in North America)

Product	Air	Water	Air/Water
0/80/retard/250 psi	PFE3932R1	-	-
0/300 psi	-	PFE3933R1	PFE3935R1
0/80/retard/250 psi/kPa	PFE3932	-	-
0/300 psi/kPa	-	PFE3933	PFE3935
0/80/retard/250 psi/bar	PFE3932R1R11	-	-
0/300 psi/bar	-	PFE3933R1R11	PFE3935R1R11
0/80/retard/250 psi/kg/cm ²	PFE3932R1R3	-	-
0/300 psi/kg/cm ²	-	PFE3933R1R3	PFE3935R1R3

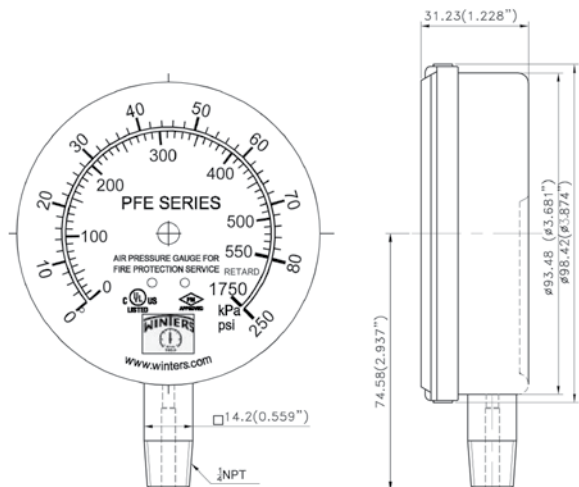

FIRE PUMP TEST METER G-500-6

CONSTRUCTION & SPECIFICATIONS

- VENTURI:** ZINC PLATED STEEL
- VALVES:** ONE PIECE BRASS BODY
ZINC DIECAST STEEL HANDLE
- ID TAG:** Chain: brass
Tag: Aluminum
- HOSES:** GOODYEAR 3/6" FREON CHARGE HOSES WITH NYTRILE CORE, POLYESTER BRAID AND NYTRILE COVER WITH PVC FOR ABRASION RESISTANCE

METER DATA

- CONSTRUCTION:** ALUMINUM BODY
- OPERATION:** BUNA "N" DIAPHRAGM
- ACCURACY:** ±2.0%
- TEMPERATURE:** 200° F MAX
- PRESSURE:** 1500 PSI MAX
- APPROX. WEIGHT:** 3 LBS/EACH

4 1/2" DIAL STANDARD - 6" AVAILABLE

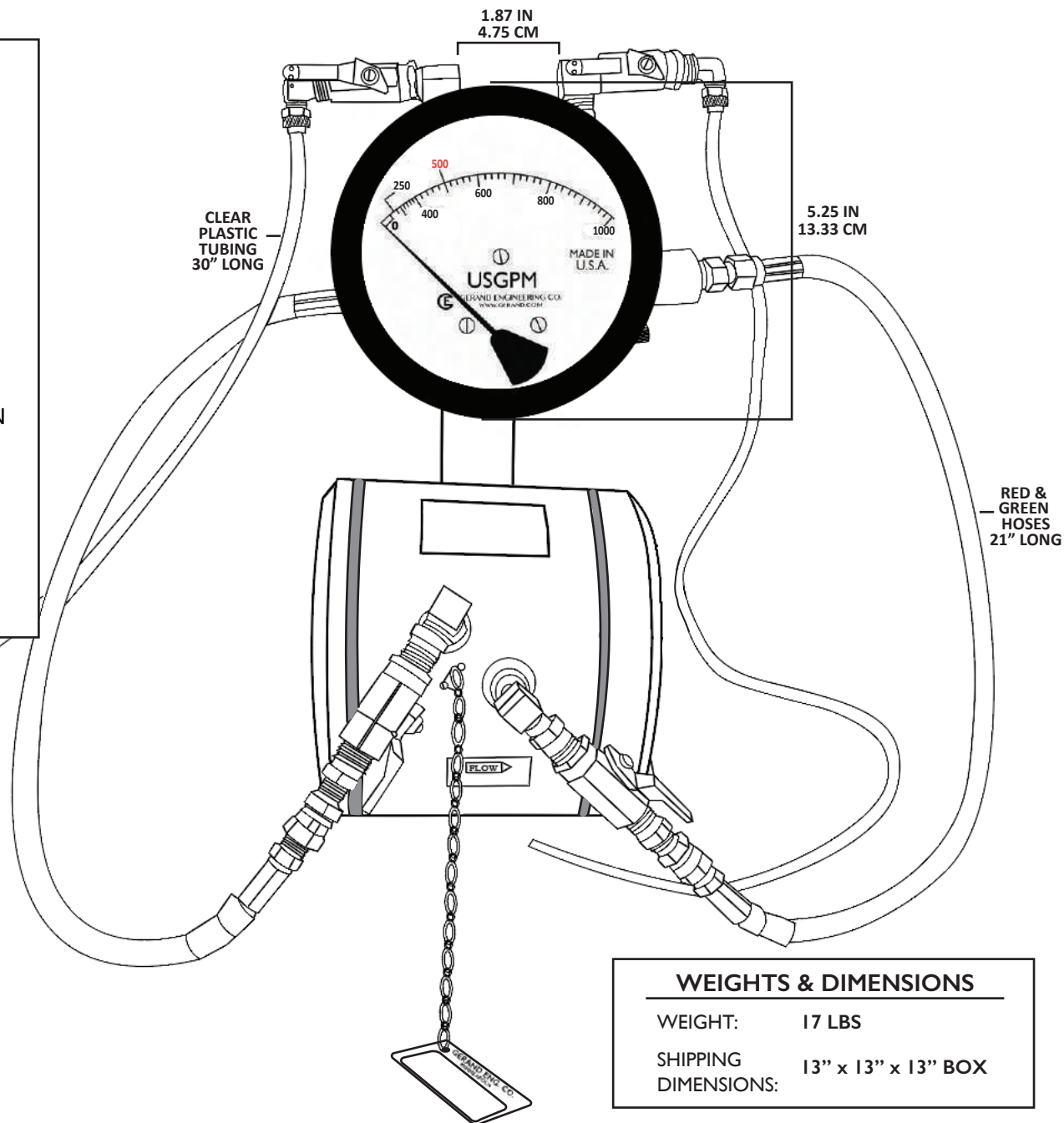

WEIGHTS & DIMENSIONS

- WEIGHT:** 17 LBS
- SHIPPING DIMENSIONS:** 13" x 13" x 13" BOX

FIRE PUMP TEST METER INSTRUCTIONS

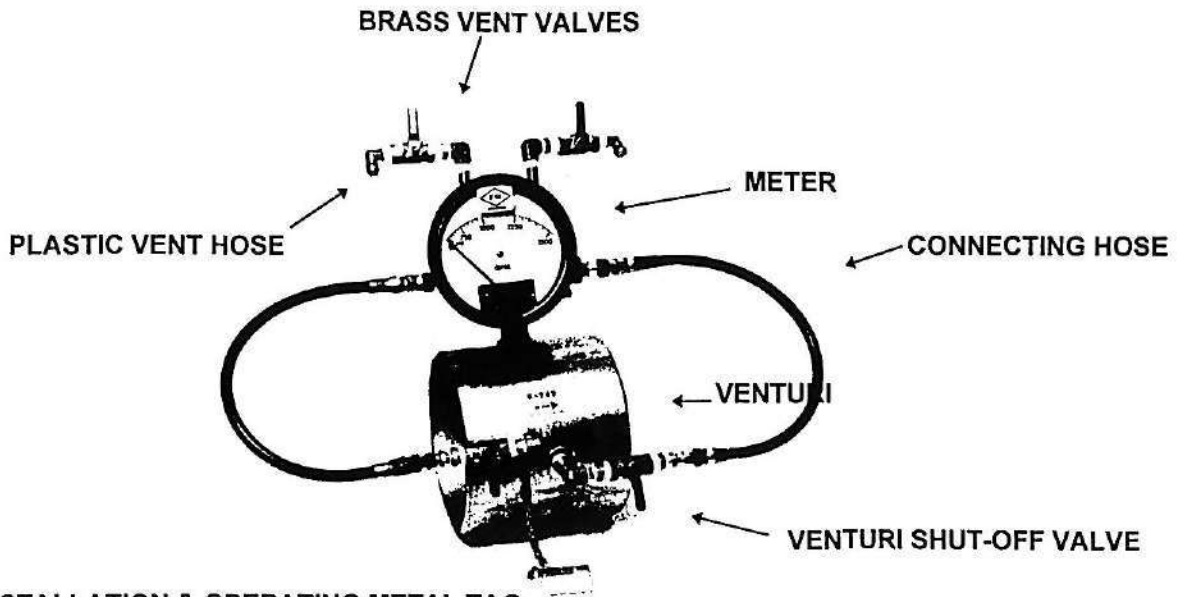

INSTALLATION & OPERATING METAL TAG
NOT SHOWN THOUGH IS PERMANENTLY
ATTACHED

OPERATING INSTRUCTIONS:

ATTACHED TO THE METER WITH A BRASS CHAIN IS AN OBLONG METAL TAG WITH THE SUGGESTED PIPING DIAGRAM OF THE SYSTEM ON ONE SIDE AND THE FOLLOWING OPERATING INSTRUCTIONS ON THE REVERSE SIDE.

1. CLOSE SYSTEM OSY VALVE "A".
2. OPEN BY-PASS VALVE AND "B" BUTTERFLY THROTTLE VALVE.
3. PURGE METER LOCATED ON VENTURI AS FOLLOWS:
OPEN STATION SHUT-OFF VALVES ON VENTURI AND VENT VALVES ATTACHED TO METER. WHEN A STEADY STREAM OF WATER WITHOUT AIR BUBBLES PASSES THROUGH THE CLEAR PLASTIC HOSES, THE METER IS PURGED OF AIR. CLOSE THE VENT VALVES AFTER PURGING.
4. START THE FIRE PUMP AND READ METER IN GPM.
5. REFER TO PUMP GPM REQUIREMENT AND ADJUST THROTTLE VALVE TO MEET THE REQUIREMENT.
6. AFTER THE TEST, OPEN VALVE "A" AND CLOSE THE BY-PASS AND "B" VALVES.

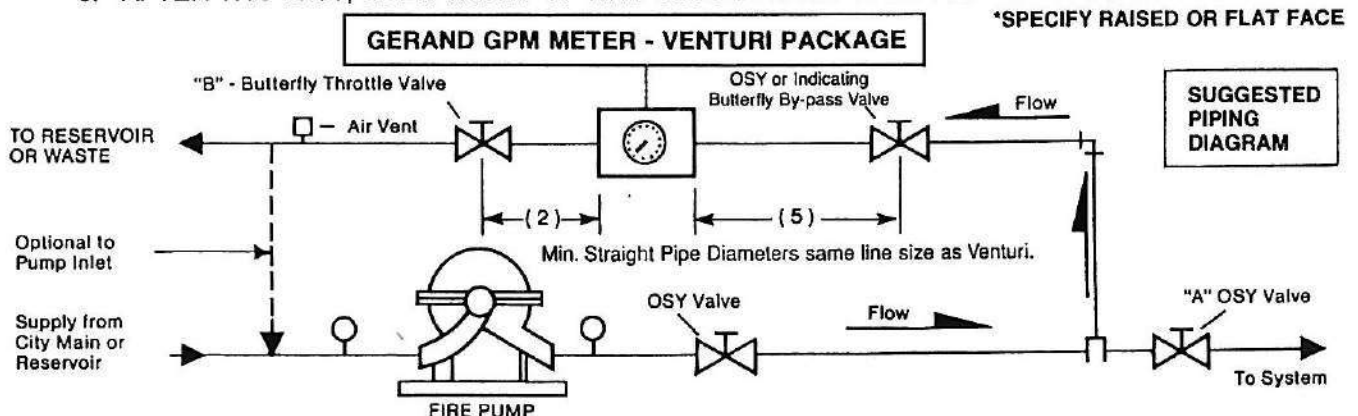

GERAND ENGINEERING CO.

11504 K-TEL DRIVE • MINNETONKA, MN 55343 USA • PHONE: 952-374-1320 FAX: 952-374-1758

BRONZE SAFETY RELIEF VALVES (Lift = D/25)

S10L

Bronze Safety Valve
with Lever

1/2" - 2"

S10

Bronze Safety Valve
with Sealing Cap

1/2" - 2"



S10L

S10

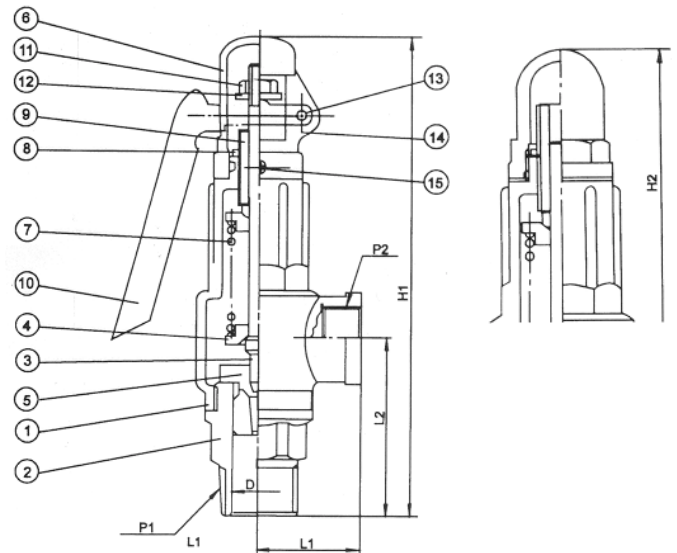

General material

Valve Body	ASTM-B584-C83600
Valve Seat	ASTM-B124-C37700
Spindle	ASTM-B16-C36000
Spring Seat	ASTM-B16-C36000
Disc	ASTM-B124-C37700
Spring	Steel or Stainless Steel
Cap	ASTM-B584-C83600 or ASTM-B124-C37700

Working Pressure : 0.3 – 10 kg/cm² (Steam)
0.3 – 10 kg/cm² (W.O.G.)

Working Temp. : - 45°C – 185°C

Working Fluid (S10): Non Corrosive Gas
Steam
Hot Water
Non Corrosive Liquid

Working Fluid (S10L): Non Corrosive Gas
Steam

Dimension.

Size	P1 (Inlet)	D (Seat dia.)	P2 Outlet	Lift	L1	L2	H1	H2	Weight(kg)	
									S10	S10L
1/2"	RC(1/2)	13	G(1/2)	0.52	32	52	162	140	0.51	0.58
3/4"	RC(3/4)	19	G(3/4)	0.76	36	58	172	150	0.63	0.73
1"	RC(1)	25	G(1)	1.00	40	71	204	185	1.14	1.29
1-1/4"	RC(1-1/4)	32	G(1-1/4)	1.28	52	83	223	208	2.03	2.03
1-1/2"	RC(1-1/2)	38	G(1-1/2)	1.52	58	96	252	236	2.6	2.61
2"	RC(2)	50	G(2)	2.00	65	103	287	265	3.84	4.1

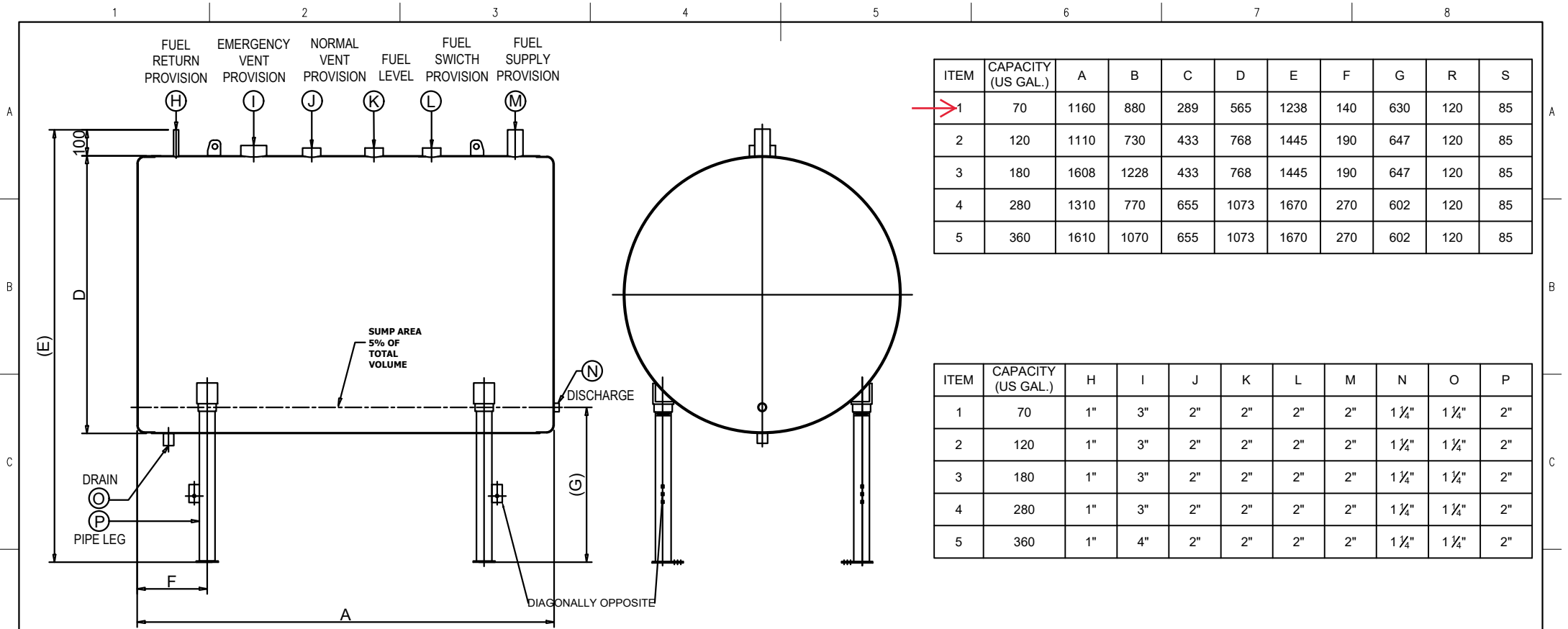

ITEM	CAPACITY (US GAL.)	A	B	C	D	E	F	G	R	S
1	70	1160	880	289	565	1238	140	630	120	85
2	120	1110	730	433	768	1445	190	647	120	85
3	180	1608	1228	433	768	1445	190	647	120	85
4	280	1310	770	655	1073	1670	270	602	120	85
5	360	1610	1070	655	1073	1670	270	602	120	85

ITEM	CAPACITY (US GAL.)	H	I	J	K	L	M	N	O	P
1	70	1"	3"	2"	2"	2"	2"	1 1/4"	1 1/4"	2"
2	120	1"	3"	2"	2"	2"	2"	1 1/4"	1 1/4"	2"
3	180	1"	3"	2"	2"	2"	2"	1 1/4"	1 1/4"	2"
4	280	1"	3"	2"	2"	2"	2"	1 1/4"	1 1/4"	2"
5	360	1"	4"	2"	2"	2"	2"	1 1/4"	1 1/4"	2"

- NOTE:-
- 3MM THICK MS SHEET END CAP
 - 3MM THICK MS SHEET SHELL
 - THE DIMENSION IN () ARE VARIABLE AS PER THE CONSTRUCTIONAL FEATURES
 - LIFTING TO BE DONE WITHOUT FUEL(EMPTY LIFTING)

Rev.	Revision Note	Drawn	Rev'd	App'd	Date
A	Initial release	VT	AL	NM	14.09.2022

UNLESS OTHERWISE SPECIFIED ALL DIMENSION IN MM.
DIMENSIONS IN () ARE VARIABLE.
TOLERANCE EXCEPT WHERE OTHERWISE STATED ± (mm)
SHEET THICKNESS ±0.5 MM
100 AND UNDER ±4 MM
OVER 100 UP TO 1000 ±8 MM
OVER 1000 ±12 MM
ANGULAR ±0.5°
HOLE POSITIONS ± 0.5

THIS DRAWING AND THE INFORMATION HEREON ARE OUR PROPERTY AND MAY BE USED BY OTHERS ONLY AS AUTHORIZED BY US. UNPUBLISHED--ALL RIGHTS RESERVED UNDER THE COPYRIGHT LAWS.

Item Ref: DT-360
 Drawn: VT
 Checked: AL
 Approved: NM

BRISTOL

CONTROLLED DRAWING

- DO NOT SCALE DRAWING -

Drg. No.: BFE-PU11-DSW-001	Rev.: A	Scale: NTS
Title: GENERAL ASSEMBLY DRAWING FOR SINGLE WALL DIESEL TANK (LISTED)		
REFERENCE: -	Finished: -	Sheet: 1/1

CERTIFICATE

Fire Fighting Solutions Provider

ص.ب: ٧٤٥٨٢ . دبي الامارات العربية المتحدة تيلفون : ٣٤٧٧٠٧٣ / ٣٤٧٢٤٢٦ +٩٧١ ٤ ٣٤٧٢٣٦٣ فاكس : +٩٧١ ٤ ٣٤٧٢٣٦٣

P.O. Box 74582 Dubai UAE. Tel: +971 4 3472426 / 3477073. Fax: +971 4 3472363. E-mail: info@hritel-fire.com www.hritel-fire.com



QWZU.EX16459 - Centrifugal Fire Pumps, End Suction

Centrifugal Fire Pumps, End Suction

[See General Information for Centrifugal Fire Pumps, End Suction](#)

BRISTOL FIRE ENGINEERING L L C

AL QUOZ INDUSTRIAL AREA 3
PO BOX 74582
DUBAI, UNITED ARAB EMIRATES

EX16459

Rated Capacity GPM	Size In.	Model Dsg	Rated Net Pressure Range psi	Approx Speed RPM	Max Working Pressure psi
50	2x1-1/4	IS32-200	62-95	2950	230
50	2x1-1/4	IS32-200	55-85	2800	230
50	2x1-1/4	IS32-260	113-130	2950	230
50	2-1/2x2	IS50-320H	103-167	2600	220
50	2-1/2x2	IS50-320H	88-142	2400	220
100	2x1-1/4	IS32-260	103-125	2950	230
100	2-1/2x2	IS50-320H	178-298	3500	330
100	2-1/2x2	IS50-320H	132-210	2950	240
100	2-1/2x2	IS50-320H	119-189	2800	240
100	2-1/2x2	IS50-320H	102-166	2600	220
100	2-1/2x2	IS50-320H	87-141	2400	220
100	3x2-1/2	BEP 3x2.5 LP	60-92	2950	160
100	3x2-1/2	BEP 3x2.5 LP	62-95	3000	160
100	3x2-1/2	BEP 3x2.5 LP	87-134	3550	160
150	2-1/2x2	IS50-320H	177-296	3500	330
150	2-1/2x2	IS50-320H	132-209	2950	240
150	2-1/2x2	IS50-320H	118-188	2800	240
150	2-1/2x2	IS50-320H	99-165	2600	220
150	2-1/2x2	IS50-320H	84-140	2400	220

300	4x3	IS80-320H	143-183	2800	220
300	4x3	IS80-260	167-222	3550	260
400	4x3	BEP 4x3 LP	54-87	2950	160
400	4x3	BEP 4x3 LP	56-90	3000	160
400	4x3	BEP 4x3 LP	79-127	3550	160
400	4x3	IS80-260	165-222	3550	260
400	4x3	IS80-260	109-144	3000	230
400	4x3	IS80-260	105-139	2950	230
400	4x3	IS80-320H	158-203	2950	220
400	4x3	IS80-320H	142-183	2800	220
400	5x4	IS100-320H	133-163	3000	260
400	5x4	IS100-320H	123-158	2950	260
400	5x4	IS100-320H	110-142	2800	260
400	5x4	IS100-320H	98-172	2600	220
400	5x4	IS100-320H	83-147	2400	220
450	4x3	BEP 4x3 LP	53-85	2950	160
450	4x3	BEP 4x3 LP	55-88	3000	160
450	4x3	BEP 4x3 LP	78-126	3550	160
450	4x3	IS80-320H	157-203	2950	220
450	4x3	IS80-320H	140-182	2800	220
450	5x4	IS100-320H	133-164	3000	260
450	5x4	IS100-320H	122-158	2950	260
450	5x4	IS100-320H	110-142	2800	260
450	5x4	IS100-320H	98-172	2600	260
450	5x4	IS100-320H	83-147	2400	260
500	4x3	BEP 4x3 LP	51-84	2950	160
500	4x3	BEP 4x3 LP	53-87	3000	160
500	4x3	BEP 4x3 LP	78-125	3550	160
500	4x3	IS80-260	163-220	3550	260
500	4x3	IS80-260	106-142	3000	230
500	4x3	IS80-260	101-137	2950	230

500	4x3	IS80-320H	155-202	2950	220
500	4x3	IS80-320H	136-182	2800	220
500	5x4	IS100-320H	124-234	3000	260
500	5x4	IS100-320H	122-226	2950	260
500	5x4	IS100-320H	110-142	2800	260
500	5x4	IS100-320H	97-172	2600	260
500	5x4	IS100-320H	82-147	2400	260
500	5x4	IS100-260	144-212	3550	260
750	5x4	IS100-320H	124-153	3000	220
750	5x4	IS100-320H	119-224	2950	260
750	5x4	IS100-320H	104-131	2800	260
750	5x4	IS100-320H	89-166	2600	260
750	5x4	IS100-260	113-139	2950	230
750	5x4	IS100-260	118-144	3000	260
750	5x4	IS100-260	140-212	3550	260
1000	5x4	IS100-260	104-131	2950	230
1000	5x4	IS100-260	109-137	3000	230
1000	5x4	IS100-260	132-208	3550	260

Trademark and/or Tradename: "BRISTOL", **BRISTOL**

Last Updated on 2020-05-21

The appearance of a company's name or product in this database does not in itself assure that products so identified have been manufactured under UL's Follow-Up Service. Only those products bearing the UL Mark should be considered to be Certified and covered under UL's Follow-Up Service. Always look for the Mark on the product.

UL permits the reproduction of the material contained in the Online Certification Directory subject to the following conditions: 1. The Guide Information, Assemblies, Constructions, Designs, Systems, and/or Certifications (files) must be presented in their entirety and in a non-misleading manner, without any manipulation of the data (or drawings). 2. The statement "Reprinted from the Online Certifications Directory with permission from UL" must appear adjacent to the extracted material. In addition, the reprinted material must include a copyright notice in the following format: "© 2021 UL LLC"



Certificate of Compliance

This certificate is issued for the following:

**Centrifugal Fire Pumps
(Horizontal, End Suction Type)**

IS 80-260, IS 100-260 and IS 100-320H
(see ratings on page 2)

Prepared for:

Bristol Fire Engineering L.L.C.
Al Quoz Industrial Area 3
P.O. Box 74582
Dubai, United Arab Emirates

FM Approvals Class: 1319

Approval Identification: 3059489

Approval Granted: January 24, 2017

To verify the product continues to be Approved please refer to www.approvalguide.com.

Said Approval is subject to satisfactory field performance, continuing Surveillance Audits, and strict conformity to the constructions as shown in the Approval Guide, an online resource of FM Approvals.

A handwritten signature in black ink that reads 'D.B. Fuller'.

David B. Fuller
AVP, Manager of Fire Protection
FM Approvals
1151 Boston-Providence Turnpike
Norwood, MA 02062 USA



Member of the FM Global Group

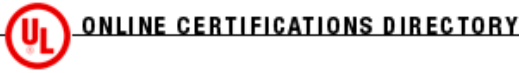

**QYZS.EX3971
Pump Controllers, Fire**

Page Bottom

Pump Controllers, Fire

See General Information for Pump Controllers, Fire

TORNATECH INC

EX3971

#132

7075 PLACE ROBERT-JONCAS

ST LAURENT, QC H4M 2Z2 CANADA

Fire Pump Controllers: Model AF, AFP, AFR, AFY, ATF, ATR, ATP or ATY followed by C or N, followed by additional suffixes. All of the above controllers are suitable for use on circuits capable of delivering high fault currents. The withstand ratings are as follows:

Circuit Breaker	Max V AC	Max Short Circuit Current RMS Symmetrical Amps
MZMH6-63, -100,	208; 240	25000; 42,000
-160, -250		
MZMH6-63, -100,	480	65,000
160, -250		

The controllers provided with Automatic Transfer Switches are suitable for use on circuits capable of delivering high fault currents. The withstand rating of the normal power source side is determined by the transfer switch as indicated below:

ASCO Transfer Switch	Max Controller Short Circuit Withstand Rating
9403704	22KA, 480 VAC Max
94031004	22KA, 480 VAC Max
94032604	35KA, 480 VAC Max

The withstand ratings for the alternate power source side will be dependent upon the ratings of the external circuit breaker provided. But in no case will they exceed those of the normal power source side.

Model AL or AL1 followed by additional suffixes.

All of the above controllers are suitable for use on circuits capable of delivering high fault currents. The withstand ratings are as follows:

Circuit Breaker	Max V AC	Max Short Circuit Current RMS Symmetrical Amps
NZM6B-63,	480	25,000
-100, -160		

The controllers provided with automatic Transfer Switches are suitable for use on circuits capable of delivering high fault currents. The withstand rating of the entire controller is determined by the transfer switch as indicated below:

ASCO Transfer Switch	Max Controller S. C. Withstand Rating
9403704	22KA, 480 VAC Max
94031004	22KA, 480 VAC Max
94032604	25KA, 480 VAC Max

The withstand ratings for the alternate power source side will be dependent upon the ratings of the external circuit breaker provided. But in no case will they exceed those of the normal power source side.

Authorities having jurisdiction should be consulted in all cases.

Model FPD Series controller for engine-driven centrifugal fire pumps.

Models FPA, FPP, FPR, FPS, FPV, FPW, FPY, VPA, VPR, and VPS may be followed by additional suffixes. The withstand ratings are as follows:

Withstand Ratings of Controllers Without Transfer Switch:

Short Circuit Withstand Ratings (Ampere Symmetrical)

VOLTAGE	STANDARD	OPTIONAL HIGH
200 to 480 V	100,000A RMS	150,000A RMS
575 to 600 V	50,000A RMS	100,000A RMS

Model ATG or VPG. The controllers provided with Automatic Transfer Switches are suitable for use on circuits capable of delivering high fault currents. The withstand rating of the normal power side is the same as the withstand ratings of controllers without transfer switches. The withstand rating of the alternate power side is determined by the transfer switch as indicated by the following tables:

Withstand ratings of controllers with 120 A Tornatech Inc. Transfer Switch

200-208V 50/60 Hz MAX HP	230-240V 50/60 Hz MAX HP	380-416V 50/60 Hz MAX HP	440-480V 50/60 Hz MAX HP	600V 60Hz MAX HP	Withstand Rating (A)
40	40	—	—	—	65,000
—	—	60	75	—	25,000
—	—	—	—	100	18,000

Withstand Ratings For Controllers with Ascoelectric Transfer Switches

Transfer Switch (A)	200-208V 50/60 Hz Max HP	230-240V 50/60 Hz Max HP	Withstand Rating		Specific** Withstand Rating (A)
			(A)	Time (Cycles)	
100	30	30	10000	1.5	22000
150	50	50	1000	1.5	22000
400	150	150	35000	3	42000
600	N/A	N/A	50000	3	65000

**Tested and found suitable for 100kA

Withstand Ratings for Controllers with Ascoelectric Transfer Switches, Continued

Transfer Switch (A)	600V 60 Hz Max HP	Withstand Rating		Specific Withstand Rating (A)
		(A)	Time (Cycles)	
100	75	10000	1.5	N/A
150	150	1000	1.5	N/A
400	400	22000	3	N/A
600	N/A	N/A	N/A	N/A
Model ATU:	Normal Power Side:	Same as withstand rating of controller without transfer switch.		
	Alternate Power Side:	Same as withstand rating of controller without transfer switch.		
Model FPL, GPL:	Limited Service controllers with withstand ratings as follows:			
Short Circuit Withstand Ratings of Limited Service Controllers Without Transfer Switches				
VOLTAGE	STANDARD	OPTIONAL HIGH		
200 to 480 V	25,000 A RMS	65,000 A RMS		
575 to 600 V	18,000 A RMS	25,000 A RMS		
Model LTG, GLG:	Automatic transfer switch for connection to a generator set.			
Model LTU, GLU:	Automatic transfer switch for connection to a 2 nd utility.			

Withstand ratings of Controller with transfer switch Model FPAT (Tornatech):

Model LTG:	Normal Power Side:	Same as withstand rating of controller without transfer switch.		
	Alternate Power Side:	Withstand rating only applies when the generator set is protected by a molded case circuit breaker		
TRANSFER SWITCH AMPERES		200-480 V H.P.	WITHSTAND RATING AMPERES	
120		30	25,000	

TRANSFER SWITCH AMPERES		600 V H.P.	WITHSTAND RATING AMPERES	
120		30	18,000	
Model LTU:	Normal Power Side:	Same as withstand rating of controller without transfer switch.		
	Alternate Power Side:	Same as withstand rating of controller without transfer switch.		

Withstand ratings of controller with transfer switch Model 940 (Ascolectric):

Model LTG:	Normal Power Side:	Same as withstand rating of controller without transfer switch.		
	Alternate Power Side:	Withstand rating only applies when the generator set is protected		
		by a molded case circuit breaker not exceeding the ampere rating of		
		the transfer switch.		
Transfer Switch A	200-480 V Max HP	Withstand Rating		Specific Withstand Rating A
		A	Time	
120	30	10,000	1.5	22,000
Transfer Switch A	600 V Max HP	Withstand Rating		Specific Withstand Rating A
		A	Time	
120	30	10,000	1.5	N/A
Model LTU:	Normal Power Side:	Same as withstand rating of controller without transfer switch.		
	Alternate Power Side:	Same as withstand rating of controller without transfer switch.		

Models CPA, CPP, CPR, CPS, CPV, CPW, CPY, may be followed by additional suffixes. The withstand ratings are as follows:

Withstand ratings of controllers without transfer switch:

Short circuit withstand ratings (ampere symmetrical)	voltage	
	standard	optional
200 to 480 V	100 kA	150 kA
575 to 600 V	50 kA	100 kA

Model CPU - The controllers provided with automatic transfer switches are suitable for use on circuits capable of delivering high fault currents. The withstand rating of the normal power side and the alternate power side is the same as the withstand ratings of controllers without transfer switches.

Model CPU

Short circuit withstand rating for alternate power circuit with transfer switch (RMS Symmetrical)	v	
	Standard	High (optional)
200 to 480 V	100 kA	150 kA
575 to 600 V	50 kA	100 kA

Model GPD Series controller for engine-driven centrifugal fire pumps.

Battery chargers, BCE10, followed by 12 or 24, followed by 120 or 220.

Fire pump controllers, Models GPA, GPP, GPR, GPS, GPV, GPY and GPW.

Transfer switch, Model GPU.

Last Updated on 2013-01-03

[Questions?](#)

[Print this page](#)

[Terms of Use](#)

[Page Top](#)

© 2014 UL LLC

When the UL Leaf Mark is on the product, or when the word "Environment" is included in the UL Mark, please search the [UL Environment database](#) for additional information regarding this product's certification.

The appearance of a company's name or product in this database does not in itself assure that products so identified have been manufactured under UL's Follow-Up Service. Only those products bearing the UL Mark should be considered to be Certified and covered under UL's Follow-Up Service. Always look for the Mark on the product.

UL permits the reproduction of the material contained in the Online Certification Directory subject to the following conditions: 1. The Guide Information, Assemblies, Constructions, Designs, Systems, and/or Certifications (files) must be presented in their entirety and in a non-misleading manner, without any manipulation of the data (or drawings). 2. The statement "Reprinted from the Online Certifications Directory with permission from UL" must appear adjacent to the extracted material. In addition, the reprinted material must include a copyright notice in the following format: "© 2014 UL LLC".



UL Product iQ
 UL'S NEXT GENERATION CERTIFICATIONS SEARCH
 The same trusted data in a modern search engine.

NOW AVAILABLE
 > **LEARN MORE**

QYLU.EX6155 Internal-combustion Engines for Driving Stationary Fire Pumps

[Page Bottom](#)

Internal-combustion Engines for Driving Stationary Fire Pumps

[See General Information for Internal-combustion Engines for Driving Stationary Fire Pumps](#)

CLARKE FIRE PROTECTION PRODUCTS LTD

EX6155

GRANGE WORKS

LOMOND RD

COATBRIDGE, ML5 2NN UNITED KINGDOM

DIESEL ENGINES RATED AT SPECIFIC SPEEDS

Model	No. of Cylinders	Rated HP	Rated Speed (rpm)
JU4H-UF04	4	50	2350
JU4H-UF04	4	55	2600
JU4H-UF04	4	60	2800
JU4H-UF04	4	60	3000
JU4H-UF10	4	41	1760
	4	51	2100
	4	55	2350
JU4H-UF12	4	55	2350
	4	59	2600
JU4H-UF14	4	55	2350
	4	59	2600
	4	70	2800
JU4H-UF20	4	71	3000
	4	60	1760
	4	67	2100
	4	72	2350
JU4H-UF22	4	72	2350
	4	75	2600
JU4H-UF24	4	72	2350
	4	75	2600



**QXZF.EX5189
Fire Pump Motors**

Page Bottom

Fire Pump Motors

See General Information for Fire Pump Motors

NIDEC MOTOR CORP

EX5189

8050 W FLORISSANT AVE

SAINT LOUIS, MO 63136-1414 USA



Model No.	Output	Volts	FL Amps	Service Factor	Poles	Number of Speeds	RPM	Phases	Ins Class	Prot. Type	Rated Ambient (°C)	CCN
Frame 182 thru 215 (v) (+)	15hp	190-660	-	1.15	-	-	-	3	F	-	50	QXZF
Frame 250 thru 286 (v) (+)	7.5-60hp	190-660	-	1.15	-	-	-	3	F	-	50	QXZF
Frame 320 thru 5012 (v) (+)	40-500hp	190-660	-	1.15	-	-	-	3	F	-	50	QXZF
Frame 56 thru 145 (v) (+)	3hp	190-660	-	1.15	-	-	-	3	F	-	40	QXZF

(+) - Motors have also been evaluated as inverter duty (PRHJ) motors.

(v) - Voltage range details: 190, 200, 208, 230, 380, 400, 415, 460, 575, 660 or 208-230/460.

Trademark and/or Tradename: "Nidec Motor Corporation"

Last Updated on 2014-03-27

[Questions?](#)

[Print this page](#)

[Terms of Use](#)

[Page Top](#)

© 2014 UL LLC

When the UL Leaf Mark is on the product, or when the word "Environment" is included in the UL Mark, please search the [UL Environment database](#) for additional information regarding this product's certification.

The appearance of a company's name or product in this database does not in itself assure that products so identified have been manufactured under UL's Follow-Up Service. Only those products bearing the UL Mark should be considered to be Certified and covered under UL's Follow-Up Service. Always look for the Mark on the product.

UL permits the reproduction of the material contained in the Online Certification Directory subject to the following conditions: 1. The Guide Information, Assemblies, Constructions, Designs, Systems, and/or Certifications (files) must be presented in their entirety and in a non-misleading manner, without any manipulation of the data (or drawings). 2. The statement "Reprinted from the Online Certifications Directory with permission from UL" must appear adjacent to the extracted material. In addition, the reprinted material must include a copyright notice in the following format: "© 2014 UL LLC".



QXZF.EX5990 Fire Pump Motors

[Page Bottom](#)

Fire Pump Motors

[See General Information for Fire Pump Motors](#)

WEG EQUIPAMENTOS ELETRICOS SA

EX5990

AV PREF WALDEMAR GRUBBA 3000

89256-900 JARAGUA DO SUL, SC BRAZIL

Model No.	Output	Hz/DC	Volts	FL Amps	Service Factor	Poles	Number of Speeds	RPM	Phases	Ins Class	Prot. Type	Rated Ambient (°C)
(click on a model number to see complete product details)												
1 through 9; followed by U; followed by T; followed by 0 or E; followed by D, F, I, J, L, P, 2, ?,] or +; followed by C or F; followed by A, D, G, H, I, J, K, M, N, P, 3 or 4; followed by I or N; followed by M, P or X; followed by H, N, P, T, or X; followed by three digits; followed by 02, 04 or 06; may be followed by E, O, or P; may be followed by additional letters or numbers; may be followed by Z. (v)												
	1-500hp	50, 60, 50, 60, 50, 60	190-600	-	1.0-1.15	2, 2, 4, 4, 6, 6	1	3000, 3600, 1500, 1800, 1000, 1200	3	H	-	40
T; followed by O or E; followed by 0+, 0F, 0I, 0J, 0O, 0P; followed by C or F; followed by 04, 0D, 0G, 0H, 0I, 0J, 0K, 0L, 0M, 0N, 0P, 0Q, 0R, 0T, 0U or 0X; followed by 0A, 0C, 0D, 0E, 0F, 0H, 0I, 0J, 0K, 0L, 0M, 0N, 0P, 0R, 0S, 0T, 0W, or 0X; may be followed by 00001, 00003 or 00009; may be followed by 00001 through 99999. (v)												
	1-500hp	50, 60, 50, 60, 50, 50	190-600	-	1.0-1.15	2, 2, 4, 4, 6, 6	1	3000, 3600, 1500, 1800, 1000, 1200	3	H	-	40
T; followed by O; followed by 0+, 0I, 0J, 0O, 0P; followed by C or F; followed by 04, 0D, 0G, 0H, 0I, 0J, 0K, 0L, 0M, 0N, 0P, 0Q, 0R, 0T, 0U or 0X; followed by 0A, 0C, 0D, 0E, 0F, 0H, 0I, 0J, 0K, 0L, 0M, 0N, 0P, 0R, 0S, 0T, 0W, or 0X; may be followed by 00001, 00003 or 00009; may be followed by 00001 through 99999. (v)												
	1-450hp, 1.5-500hp, 1-350hp, 1-400hp, 1-250hp, 1-400hp	50, 60, 50, 60, 50, 60	190-600	-	1.15	2, 2, 4, 4, 6, 4	1	3000, 3600, 1500, 1800, 1000, 1800	3	F, H	-	50
	1-450hp, 1.5-500hp, 1-350hp, 1-400hp, 1-250hp, 1-300hp	50, 60, 50, 60, 50, 60	190-600	-	1.15	2, 2, 4, 4, 6, 6	1	3000, 3600, 1500, 1800, 1000, 1200	3	H	-	50
W21 Series, Motor Model T; followed by E; followed by 0+, 0F 0I, 0J, 0O, 0P; followed by C or F; followed by 04, 0D, 0G, 0H, 0I, 0J, 0K, 0L, 0M, 0N, 0P, 0Q, 0R, 0T, 0U or 0X; followed by 0A, 0C, 0D, 0E, 0F, 0H, 0I, 0J, 0K, 0L, 0M, 0N, 0P, 0R, 0S, 0T, 0W, or 0X; may be followed by 00001, 00003 or 00009; may be followed by 00001 through 99999, may be followed by 50. (v)												
	1-300hp, 1-350hp, 1-400hp, 1-500hp, 1-350hp,	50, 60, 50, 60, 50,	190-600	-	1.15	2, 2, 4, 4, 6,	1	3000, 3600, 1500, 1800, 1000,	3	H	-	50

	1-500hp	50				6		1200				
	1-350hp, 1-300hp, 1-400hp, 1-500hp, 1-350hp, 1-500hp	60, 50, 50, 60, 50, 60	190- 600	-	-	2, 2, 4, 4, 6, 6	1	3600, 3000, 1500, 1800, 1000, 1200	3	F, H	-	50
W22 Series, Motor Model T; followed by E; followed by 1B, 1E, 1F, 1G, 1H, 1I, 1J; followed by C or F; followed by 04, 0D, 0G, 0H, 0I, 0J, 0K, 0L, 0M, 0N, 0P, 0Q, 0R, 0T, 0U or 0X; followed by 0A, 0C, 0D, 0E, 0F, 0H, 0I, 0J, 0K, 0L, 0M, 0N, 0P, 0R, 0S, 0T, 0W, or 0X; followed by 00001, 00003 or 00009; followed by 00001 through 99999, and may or may not be followed by 50. +(v)												
	1-300hp, 1-350hp, 1-400hp, 1-500hp, 1-350hp, 1-500hp, 40hp, 30W	50, 60, 50, 60, 50, 60, 60	190- 600, 190- 600, 190- 600, 190- 600, 480	,	-	2, 2, 4, 4, 6, 6, 2	1	3000, 3600, 1500, 1800, 1000, 1200, 3600	3	F, H	-	50
W22 Series, Motor Model T; followed by E; followed by 1B, 1E, 1F, 1G, 1H, 1I, 1J; followed by C, F or A; followed by 04, 0D, 0G, 0H, 0I, 0J, 0K, 0L, 0M, 0N, 0P, 0Q, 0R, 0T, 0U or 0X; followed by 0A, 0C, 0D, 0E, 0F, 0H, 0I, 0J, 0K, 0L, 0M, 0N, 0P, 0R, 0S, 0T, 0W, or 0X; may be followed by 00001, 00003 or 00009; may be followed by 00001 through 99999, and may or may not be followed by 50. +(v)												
	1-300hp, 1-350hp, 1-400hp, 1-500hp, 1-350hp, 1-500hp	50, 60, 50, 60, 50, 60	190- 600	-	1.15	2, 2, 4, 4, 6, 6	1	3000, 3600, 1500, 1800, 1000, 1200	3	H	-	50

(v) - Voltage range details: 190, 200, 208, 220, 230, 240, 380, 400, 415, 440, 460, 480, 525, 575, 600, 115/208-230, 208-230, 208-230/460, 190/380, 200/400, 230/460/380, 380-415/460, 220/380/440, 230/400, 220/380, 380/440//380-400-415, 380/440-460//380-400-415.

+ - The motor is also evaluated as Inverter Duty Motors.

Last Updated on 2015-09-09

[Questions?](#)

[Print this page](#)

[Terms of Use](#)

[Page Top](#)

© 2016 UL LLC

The appearance of a company's name or product in this database does not in itself assure that products so identified have been manufactured under UL's Follow-Up Service. Only those products bearing the UL Mark should be considered to be Certified and covered under UL's Follow-Up Service. Always look for the Mark on the product.

UL permits the reproduction of the material contained in the Online Certification Directory subject to the following conditions: 1. The Guide Information, Assemblies, Constructions, Designs, Systems, and/or Certifications (files) must be presented in their entirety and in a non-misleading manner, without any manipulation of the data (or drawings). 2. The statement "Reprinted from the Online Certifications Directory with permission from UL" must appear adjacent to the extracted material. In addition, the reprinted material must include a copyright notice in the following format: "© 2016 UL LLC".



UL Product iQ
 UL'S NEXT GENERATION CERTIFICATIONS SEARCH
 The same trusted data in a modern search engine.

NOW AVAILABLE

▶ LEARN MORE

QXZF.EX5190
Fire Pump Motors

If you notice a change to your QXZF Listing Card, click [here](#) to learn more.

[Page Bottom](#)

Fire Pump Motors

[See General Information for Fire Pump Motors](#)

REGAL BELOIT AMERICA INC

EX5190

1946 W Cook Rd

Fort Wayne, IN 46818 USA

Model No.	Output	Hz/DC	Volts	FL Amps	Service Factor	Poles	Number of Speeds	RPM	Phases	Ins Class	Prot. Type	Rated Ambient (°C)
(click on a model number to see complete product details)												
143T Frame ODP	0-5hp	60	0-600	-	1 - 1.15	4	-	3600	3	F	-	55
	0-5hp	50	0-600	-	1 - 1.15	4	-	3000	3	F	-	55
	0-5hp	60	0-600	-	1 - 1.15	2	-	1800	3	F	-	55
	0-5hp	50	0-600	-	1 - 1.15	2	-	1500	3	F	-	55
145T Frame ODP	0-5hp	60	0-600	-	1 - 1.15	4	-	3600	3	F	-	55
	0-5hp	50	0-600	-	1 - 1.15	4	-	3000	3	F	-	55
	0-5hp	60	0-600	-	1 - 1.15	2	-	1800	3	F	-	55
	0-5hp	50	0-600	-	1 - 1.15	2	-	1500	3	F	-	55
182T	2hp	50	190/380	6/3	-	2	-	3000	3	H	-	55
	3hp	60&50	190/380	9/4.5	-	2	-	3600&3000	3	H	-	55
	3hp	60&50	200/400	8.6/4.3	-	2	-	3600&3000	3	H	-	55
	3hp	60&50	208/416&208/415	8.2/4.1	-	2	-	3600&3000	3	H	-	55
	3hp	60&50	220/440	7.8/3.9	-	2	-	3600&3000	3	H	-	55
	3hp	60&50	220/380	9/4.5&7.8/4.5	-	2	-	3600&3000	3	H	-	55
	3hp	60&50	230/460	7.4/3.7	-	2	-	3600&3000	3	H	-	55
	3hp	60&50	240/480	7/3.5&7.2/3.6	-	2	-	3600&3000	3	H	-	55
	3hp	60/50	575	3	-	2	-	3600/3000	3	H	-	55
	2hp	50/60	190/380	7.4/3.7	-	4	-	1500	3	H	-	55
	2hp	50	200/400	7.8/3.9	-	4	-	1500	3	H	-	55
	2hp	50	208/415	8.8/4.4	-	4	-	1500	3	H	-	55
	3hp	60&50	190/380	10.4/5.2&9.8/4.9	-	4	-	1800&1500	3	H	-	55
3hp	60&50	200/400	9.8/4.9&9.4/4.7	-	4	-	1800&1500	3	H	-	55	
3hp	60&50	208/416&208/415	9.6/4.8&9/4.5	-	4	-	1800&1500	3	H	-	55	
3hp	60&50	220/440	9/4.5&8.4/4.2	-	4	-	1800&1500	3	H	-	55	
3hp	60&50	220/380	10.4/5.2&8.5/4.9	-	4	-	1800&1500	3	H	-	55	

	408kW												
Model PRODUCT; followed by 0 through 9 or A through Z; followed by 0 through 9 or A through Z; followed by LM; followed by a five or six digit number; may or may not be followed by one or two letters A through ZZ; may or may not be followed by one or two letters A through Z; may or may not be followed by R; may or may not be followed by 0 through 999 or one or two letters A through Z; all followed by H.													
	0.75-408kW	50/60	220-690	-	1.15	2/4	1	-	3	F	-	55	
Models 0 through 9 or any letter A through Z; followed by any Letter A through N; followed by 143T, 145T, 182T, 184T, 213T, 215T, 254T, 256T, 284T, 284TS, 286T, 286TS, 324T, 324TS, 326T, 326TS, 364T, 364TS, 365T, 365TS, 404T, 404TS, 405T, 405TS, 444T, 444TS, 445T, 445TS, 447T, 447TS, 449T or 449TS; followed by the Letter T; followed by the Letter F; followed by the Letter C; followed by the Letter D; followed by one to five Digits 0 through 99999; which may or may not be followed by any Letter A through Z; which may or may not be followed by Letter A through Z; which may or may not be followed by the letter R; followed by one to three digits 1 through 999; all followed by Letter H.													
	0.75-408kW	50/60	220-690	-	1.15	2/4	1	-	3	F	-	55	
Models 0 through 9 or any letter A through Z; followed by any Letter A through N; followed by 143T, 145T, 182T, 184T, 213T, 215T, 254T, 256T, 284T, 284TS, 286T, 286TS, 324T, 324TS, 326T, 326TS, 364T, 364TS, 365T, 365TS, 404T, 404TS, 405T, 405TS, 444T, 444TS, 445T, 445TS, 447T, 447TS, 449T, or 449TS; followed by the Letter T; followed by the Letter F; followed by the Letter C; followed by Letter D; followed by one to five Digits 0 through 99999; which may or may not be followed by the addition of a dash followed by a one to six digit number; which may or may not be followed by any Letter A through Z; which may or may not be followed by Letter A through Z; all followed by letter H.													
	0.75-408kW	50/60	220-690	-	1.15	2/4	1	-	3	F	-	55	
Models T; followed by letter C; followed by a letter A; followed by three digits or letter or combination of both; followed by one digit 0 through 9; followed by a letter A through D; followed by one digit 0 through 9 or any Letter A through Z; followed by one digit 1 through 5; followed by one digit 1 through 9; followed by one digit 1 through 3; followed by one digit 0 through 9 or one letter A through Z; followed by one digit 0 through 9 or one letter A through Z; followed by one digit 0 through 9 or one letter A through Z.													
	0.75-408kW	50/60	220-690	-	1.15	2/4	1	-	3	F	-	55	

[Click here to view the Colombia Market Access Certification](#)

Trademark and/or Tradename: "2GREEN", "Century", "Century Electric", "EX5190", "EconoMaster", "Fasco", "Genteq", "HeatMaster", "LEESON", "LEESON ELECTRIC", "LEESON Electric", "Lincoln Motors", "Marathon", "Marathon Electric", "Marathon Generators", "Marathon Motors", "Morrill Motors", "Regal", "Sinya Motor", "Source 1",



Last Updated on 2018-06-19

[Questions?](#)

[Print this page](#)

[Terms of Use](#)

[Page Top](#)

© 2018 UL LLC

The appearance of a company's name or product in this database does not in itself assure that products so identified have been manufactured under UL's Follow-Up Service. Only those products bearing the UL Mark should be considered to be Certified and covered under UL's Follow-Up Service. Always look for the Mark on the product.

UL permits the reproduction of the material contained in the Online Certification Directory subject to the following conditions: 1. The Guide Information, Assemblies, Constructions, Designs, Systems, and/or Certifications (files) must be presented in their entirety and in a non-misleading manner, without any manipulation of the data (or drawings). 2. The statement "Reprinted from the Online Certifications Directory with permission from UL" must appear adjacent to the extracted material. In addition, the reprinted material must include a copyright notice in the following format: "© 2018 UL LLC".

SUPPLIER COMPANY PROFILE

Fire Fighting Solutions Provider

ص.ب: ٧٤٥٨٢ . دبي الامارات العربية المتحدة تيلفون : ٣٤٧٧٠٧٣ / ٣٤٧٢٤٢٦ +٩٧١ ٤ ٣٤٧٢٣٦٣ فاكس : +٩٧١ ٤ ٣٤٧٢٣٦٣

P.O. Box 74582 Dubai UAE. Tel: +971 4 3472426 / 3472073. Fax: +971 4 3472363. E-mail: info@hritel-fire.com www.hritel-fire.com

BRISTOL

FIRE ENGINEERING

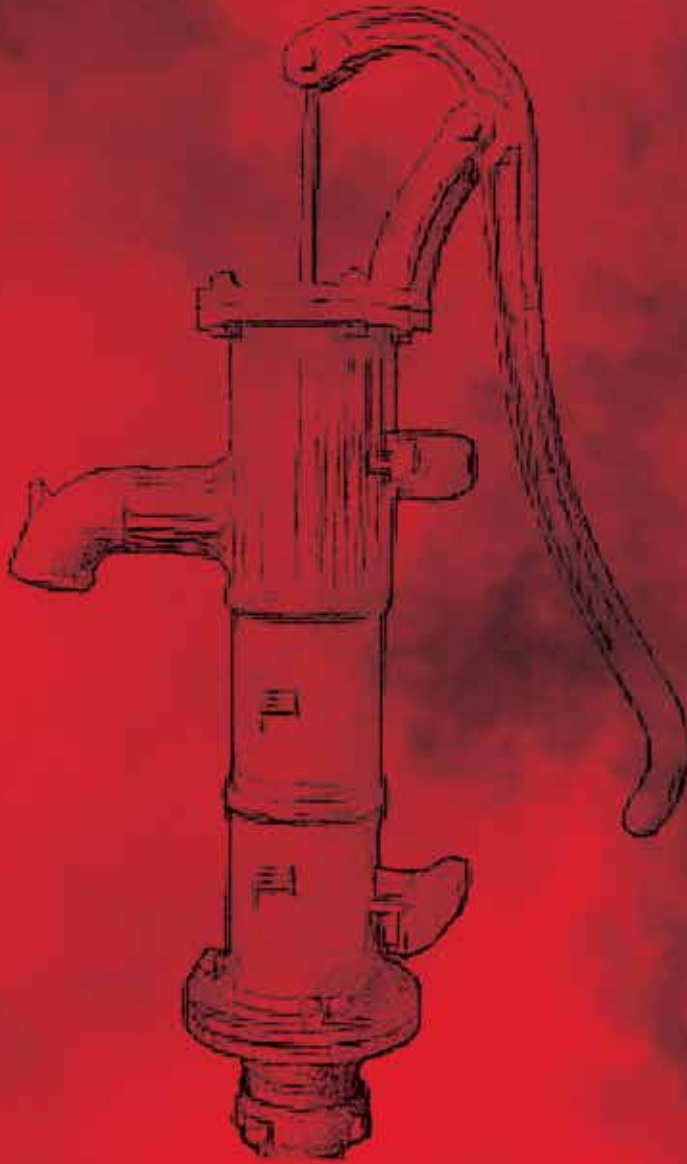

Fire Pumps



Bristol: A History & Future.

In 1971, seven emirates joined forces to create the United Arab Emirates, with the goal of becoming a growing leader on an international scale. The UAE's focus has always been the safety of its land and people, BRISTOL was established in support of that same vision.

BRISTOL FIRE ENGINEERING, part of the Concorde – Corodex Group, is the leading fire-fighting and fire protection manufacturer in the Middle East and has been unsurpassed in innovative fire-fighting solutions for more than 44 years.

We have been steadfast in our developments and have grown to become pioneers in the industry for unmatched quality and dependability, longstanding commitment and unwavering dedication.

Our headquarters and manufacturing facility started in the UAE's Emirate of Dubai, producing world-class fire-fighting systems and equipment in cooperation with international know-how and technology with a grand vision to expand globally.

We strive to continue to adopt the highest international and national standards in line with the UAE's goal to become the safest country in the world.

BRISTOL was one of the first fire-fighting companies in the Middle East to receive an ISO 9001 certification, placing great emphasis on achieving local and international approvals on product certifications such as Kite Mark, LPBC, UL listing, and FM approval. Moreover, Bristol is certified to ISO 14001 and OHSAS 18001.

We focus on innovation by means of continual research and development of advanced fire-fighting solutions, ensuring we not only meet, but exceed the demands of our rapidly changing market.

For decades, we have been proudly supplying various government entities and sectors such as the oil and gas, commercial, and industrial industries across the globe with world-class equipment and services.

BRISTOL has been serving Middle Eastern, African, Asian, and European markets for more than three decades with a vision to expand further.

Paving the road towards safety for more than four decades, and counting: BRISTOL.

